



**International
American Football
Officials Association**

Integrity - Professionalism - Development

MANUAL OF FOOTBALL OFFICIATING

Jim Briggs

20th edition

January 2026

An IAFOA publication

Copyright © IAFOA and Jim Briggs 2026

The right of Jim Briggs to be identified as the author of this work has been asserted by him under the Copyright, Designs and Patents Act 1988.

ISBN 978-1-291-85823-5 (print version)

Based on the BAFRA Manual of Football Officiating

All rights reserved. No part of this publication may be reproduced, stored in a retrieval system, or transmitted in any form or by any means, electronic, mechanical, photocopying, recording or otherwise, without prior written permission of the copyright holder.

Front cover photograph by Cliff Williams

Foreword

It's been nearly twenty years since I was introduced to the "international" game of American football, but it seems like yesterday when I accepted the invitation to officiate the IFAF World Championship in Japan. It was an opportunity to get a jump on the upcoming fall NCAA season. Not knowing what to expect, I assumed the competition and the officiating would be equal to NCAA Division II or III. What a pleasant surprise I and the other American officials were in for. The caliber of football was well beyond what we expected and the best part was what we came away with in our relationships with the fifteen other international officials.

"Our game" was now their game. We can become pretty complacent thinking that the Americans were the only ones who knew anything about football. I remember one of our outstanding mentors, Jim Keogh, telling us that we're like a piece of fruit. "When we're green we grow and when we're ripe we rot." That was Jim's message and emphasis to every official he ever came in contact with. The two weeks together with the international officials was the opportunity of a lifetime to realize we all had room to "blossom and grow".

Through that first international experience I quickly realized that as good as we think we know the rules of the game, the Japanese officials to a man knew the rulebook better than most of us. As a whole they were like former Big Ten referee Tom Quinn who could quote you chapter and verse of every rule and "AR" in the book. The Japanese officials are truly students of the game. That motivated me to spend even more time in rules study. I needed to be better than I thought I was.

Over the next few years I had the opportunity to work games and do clinics around the world. That's where my next motivation came and it involved our officiating mechanics. Again, thinking like we do, I thought I/we had a pretty good handle on mechanics and the rationale for why we do certain things on the field. Let me tell you, just like the wakeup call on rules with the Japanese officials, I got another dose of "you're not as smart as you thought you were" from British and other European IFAF officials. No one has put together a more comprehensive, black and white mechanics manual than the IAFOA manual. The Manual of Football Officiating covers everything from three to eight person crews in an in-depth manner that is more comprehensive than any NFHS or NCAA manual. This manual is an encyclopedia of the "best practices" of football officiating. The pages are devoted to individual positions, a pre-game, general principles and axioms, measurements, working with your chain crew, etc. It's as comprehensive an officiating resource as any you will read. Combine this manual with your NFHS and NCAA/CFO manuals and you and your crew will be on the road to raising your game.

Kudos to Professor Jim Briggs, the main author and chair of the IAFOA Mechanics Committee, for his leadership and work on this officiating mechanics manual. Jim exemplifies the body of officials who officiate internationally. He and his committee members have spent countless hours discussing, debating and editing the mechanics. So the next time you think of American Football as "our game", remember "our" now means the world. The international players and coaches are pretty darn good and the officiating is even better.

So whether you're a BAFRA official, an IFAF official, or an official in the United States, Japan or Brazil, the "Manual of Football Officiating" is a must read book for you. The decision is yours... "If you're green you grow. If you're ripe you rot". Which official are you? If you know everything about the game then this manual's not for you. But remember, knowledge is power and this manual will give you power through its insights and strategies for improving your individual and crew performance. The officials in Japan made me a better rules official. BAFRA and IFAF continue to motivate me to better know and understand the mechanics of officiating football.

Bill LeMonnier, Big-10 (retired), ESPN Rules Analyst

Editor's foreword

The Manual of Football Officiating (MOFO) embodies the best practice of football officiating as exemplified by top officials in the USA. The members of the International Advisory Group continue to monitor good practice in the National Football League, major college conferences and high school football, and adapt it to the particular needs of our football.

Originally developed for BAFRA members in Great Britain, this book has now been adopted as the official mechanics manual for international competitions, and is used for domestic football in many other countries, including Australia, Austria, Belgium, Chile, Czechia, Denmark, Finland, France, Hungary, Ireland, Italy, Kuwait, Netherlands, New Zealand, Norway, Poland, Serbia, Sweden and Turkey (some in translation).

A previous edition of this book published by *Referee* magazine in the USA sold 1000 copies. We are proud of the book's success and would like to take this opportunity to thank all those who have contributed to it over the years.

In this manual:

- The verb "to observe" is used in relation to a specific foul to mean that the official(s) should watch players who are at risk of committing that foul, and flag it (or take appropriate preventative action) if it happens (or comes close to happening).
- The verb "to record" implies a *written* record while the verb "to note" implies a *mental* note.
- The verb "to transmit" implies [USING O2O/CREW RADIO] to communicate with fellow officials. [O2O is an abbreviation for official-to-official.](#)
- The verb "to announce" implies communicating with players, coaches, stadium announcers, spectators and/or broadcast viewers. Often this will be [USING PUBLIC RADIO], but not always.
- Unless otherwise specified by context, the term "wing official" means either or both the [Down Judge](#) and Line Judge, the term "deep wing official" means either or both the Field Judge and the Side Judge, and the term "sideline official" means either the [Down Judge](#), Line Judge, Field Judge or Side Judge, or another official who is located on the sideline at the time.
- The following abbreviations are used to denote officiating positions:

B	Back Judge
C	Centre Judge
D	Down Judge (formerly H for Head Linesman)
F	Field Judge
L	Line Judge
R	Referee
S	Side Judge
U	Umpire
V	Video Judge

- The section entitled "Returns" in each of the positional chapters refers to fumble, backward pass, interception, punt, field goal and other returns *except* for kickoff returns, which are covered in their relevant sections.
- Rules references are to the [2026](#) edition of the *IFAF Football Rules and Interpretations* and national rulebooks derived from it, but are normally applicable to NCAA rules also.

We always encourage officials or local associations to write to us with comments on this manual and, in particular, suggestions of improvements to the mechanics which could be incorporated in future editions. Please contact me at the following email address.

Professor Jim Briggs

jim.briggs@myiafoa.org / jim.briggs.football@gmail.com

Acknowledgements

The Editor would like to thank all the members of our International Editorial Board who contributed to this edition. These include: Erik De Boeck (Belgium), Ben Griffiths (Great Britain), Paul Mercer (Australia), David Parsons (Great Britain), Peter Parsons (Great Britain), Paul Sutton (Great Britain).

The Editor is grateful to the following who contributed by helping to proof-read and check this edition: Jeff Batzler (Sweden), Amir Brooks (Great Britain), Phil Clarke (Great Britain), Eva Cloots (Belgium), John Cooper (Great Britain), Erik De Boeck (Belgium), Frank Eissa Barroso (Great Britain), Will Fazackerley (Great Britain), Perttu Hautala (Finland), Jonathan Husband (Great Britain), Radek Janhuba (Finland), Mark Looi (Australia), Ali May (Great Britain), Paul Mercer (Australia), Richard Moger (Great Britain), Dave Moore (Great Britain), Cedric Palmans (Belgium), Euan Paterson (Great Britain), Juan Perez Canto (France), Elisey Rodriguez (Portugal), Asbjorn Rohold (Denmark), Hubert Romanczyk (Poland), Mark Schofield (Great Britain), Paul Sutton (Great Britain), Liam Wooton (Great Britain).

In addition, many officials have contributed to previous editions, including: David Allan (Great Britain), Ian Barraclough (Great Britain), Einar Bolstad (Norway), Chris Bowker (Great Britain), Stephen Bowness (New Zealand), Bill Bowsher (Great Britain), Dan Bridgland (Great Britain), Arnold Buijs (Netherlands), the late Phil Cottier (Great Britain), the late Norman Cox (Great Britain), T Hutchison (Great Britain), Richard Jeffrey-Cook (Great Britain), Frank Kristensen (Denmark), Hans Lammerhirt (Germany), the late Tzvi Lindeman (Great Britain), Will Marriage (Great Britain), Russell Newton (Great Britain), the late Eigil Noren (Norway), David Norton (Great Britain), Mel Pons (Netherlands), Dominic Ray (Great Britain), Henning Rieske (Germany), Bojan Savicevic (Austria), the late David Sinclair (Australia), the late John Slavin (Great Britain), Steve Tonkinson (Great Britain), Mike Wylde (Great Britain), Brian Yates (Great Britain).

The invaluable contributions of the late Jerry Grunski, Dick Honig, Bill LeMonnier, Mike Pereira and many other US officials who have spoken at European clinics should also be acknowledged.

The Editor would also like to thank all the officials and officiating organisations who have contributed mechanics, tips and ideas.

Contents

1.	INTRODUCTION	7
2.	CHANGES TO MECHANICS	11
3.	RULES APPLICATION	14
4.	PRE-GAME CHECKLISTS	32
5.	GENERAL PRINCIPLES	34
6.	GENERAL MECHANICS	40
7.	PRE-GAME CONFERENCE	51
8.	BEFORE THE KICKOFF	54
9.	REFEREE AND CENTRE JUDGE	60
10.	UMPIRE	73
11.	DOWN JUDGE AND LINE JUDGE (CREW OF 4/5/6C)	83
12.	BACK JUDGE (CREW OF 5/6C)	97
13.	DOWN JUDGE AND LINE JUDGE (CREW OF 6D/7/8)	106
14.	FIELD JUDGE AND SIDE JUDGE (CREW OF 6D/7/8)	119
15.	BACK JUDGE (CREW OF 7/8)	131
16.	PASS PLAY COVERAGE	140
17.	TIMEOUTS	147
18.	MEASUREMENTS	149
19.	CALLING FOULS	150
20.	TIMING AND THE END OF PERIODS	156
21.	USE OF BEAN BAGS	160
22.	CHAIN CREW AND BALL PERSONS	161
23.	MECHANICS FOR CREW OF 3	164
24.	VIDEO REVIEW/INSTANT REPLAY	165
25.	RADIO COMMUNICATIONS	170
26.	AREAS OF COVERAGE	173
27.	SUPPLEMENTARY SIGNALS	187
28.	PENALTY CODES	189
29.	INDEX	192

1. INTRODUCTION

1.1 - Basic philosophy

1. Each official must fully understand the rules. However, the knowledge is not sufficient without the ability to interpret and correctly apply them. These skills can only be acquired by way of considerable effort and study.
2. In addition to the necessary rules knowledge, the official needs to know where to stand, what to look for, and of course, what to do when they see it. With these skills, officials can provide impartial administration of one of the most exciting sporting competitions, allowing it to proceed smoothly so that skillful play is not spoiled by fouls or unsportsmanlike conduct.
3. It is fundamental that the correct use of mechanics leads to better officiating. Increasingly, we see that reliable mechanics is the factor that distinguishes good officials from the rest.
4. Mechanics are two things: responsibilities and positioning. Responsibilities are paramount because unless each official performs their assigned duties for every part of each play, inevitably there will be action that is not observed. Neglecting a responsibility gives players carte blanche to violate the associated rules. Positioning is almost as important, because an official always has the best chance of making a call correctly if they are in position to get the best view of the action. The positioning mechanics in this book are based on many, many years of experience and have been found by extensive experiment to be the best.
5. **This book contains over 120,000 words and nobody can remember all of them all of the time. Therefore it is important for officials, both experienced and novice, to keep returning to the book. By re-reading sections of it, new details will emerge that will improve your effectiveness as an official. By sharing your knowledge with your colleagues, you will improve their effectiveness too.**
6. We encourage you to write out a personal checklist of things you must do and look for in each position on all possible play situations. Review and update this periodically as a reminder of what you should be doing and how best to achieve it.
7. Don't forget that football is a game played by and watched by people. As a football official, you have to appreciate the wide variety of human reactions that can arise in the charged atmosphere of a sporting competition. By developing that appreciation, you can learn to gain the respect of the players and coaches, and maintain the discipline so essential in such a physically exciting game as football.
8. The foundations of officiating:
 - (a) The first foundation of officiating a game is that it is played in a safe environment. The field, its surrounds, and the players and their equipment on it, must not pose an unreasonable risk to the participants, nor make a mockery of the game. This is often taken for granted.
 - (b) The second foundation is the respect that the players and coaches must have for the decisions made by the officials. Without that respect, anything the officials do is unlikely to significantly influence the players' behaviour. The penalties in the rulebook form an effective deterrent for illegal actions only if they have an impact on players and the game.
 - (c) Without these foundations it is next to impossible for the officials to apply the rules effectively to ensure a fair contest.
9. A textbook like this cannot hope to be definitive about every possible situation that might arise in a game of football.
 - (a) That means you have to decide for yourself what is the best response to what happens. That doesn't mean that you can "freelance" and do whatever you want. You have responsibilities at all times to your colleagues to be in the expected place and to be covering your priorities. Only by working together can your crew expect to officiate a game successfully. Only by being in the right place at the right time can you play your role in that.
 - (b) This book tells you the best place to be for common situations, and how to respond to common occurrences (and a few rare ones). Everything else is up to you.

1.2 - Crew formations

1. Our mechanics cover crews of any size from 3 to 8 (9 with a Video Judge).[◇] While crew of 3 mechanics are covered in a specific chapter, mechanics relating to other sizes of crew are spread through most of the chapters of the book. In the past, we have distinguished the crew's formation simply by its size, but developments in officiating mean that this is no longer appropriate - for the same number of officials, we potentially have multiple crew formations. For example, traditionally a crew of 6 has two officials deep (the Field Judge and the Side Judge). However, an alternative is to have only one official deep and add a Centre Judge.
2. In the same way that people talk about soccer teams as being in a 4-3-3 or 4-4-2 formation (where the digits represent the number of defenders, midfielders and forwards), we describe the composition of a crew in terms of the number of officials in each of three groups.
3. The groups are:

Core group	Referee (R), Centre Judge (C), Umpire (U)
Wing group	Down Judge (D), Line Judge (L)
Deep group	Back Judge (B), Field Judge (F), Side Judge (S)

4. We represent the crew scrimmage formation in a 3-digit notation where:
 - (a) the first digit represents the number of officials in the core group
 - (b) the second digit represents the number of officials in the wing group
 - (c) the third digit represents the number of officials in the deep group
5. The exception to this is on free kicks, where the formation used is based entirely on the size of the crew. In free kick situations, we refer to crew formations as F4, ..., F8 where the digit denotes the size of the crew.
6. These notations reflect that future developments in football officiating may add an additional official to any group. ^x
7. In this notation, we use 2xx to mean a crew that has two officials in the core group, regardless of the number in the others. Similarly, xx3 indicates a crew that has three officials in the deep group.
8. The following are the valid crew formations we recognise:

Formation	Crew size/label	Core group	Wing group	Deep group	FK formation
120	3	R	D, L		F3
220	4	R, U	D, L		F4
221	5	R, U	D, L	B	F5
222	6D	R, U	D, L	F, S	F6
321	6C	R, U, C	D, L	B	F6
223	7	R, U	D, L	B, F, S	F7
323	8	R, U, C	D, L	B, F, S	F8

9. A crew of 6 needs to decide before a game which scrimmage formation to use. It should use a 222 formation (6D) when it expects a lot of passes, kicks or other downfield action. The crew should use a 321 formation (6C) when it expects a lot of action around the line of scrimmage. A crew should normally not change scrimmage formation during a game, but may do so if absolutely necessary and only during a game stoppage. Obviously, before making such a decision, the crew should take regard of its members' experience in the changed positions.
10. Other formations are not approved and should not be used. [§]
11. CFO mechanics require opposite officiating positions (D/S, L/F) to swap sidelines at half-time. IAFOA mechanics require officiating positions to stay on the same sideline for the entire game. If, for some reason, it is necessary to swap personnel, then the person who was **D in the first half** becomes L in the second half, and vice versa. Similarly, F and S would switch roles.

1.3 - Points of emphasis

For this edition, we wish officials to take particular note of the following points.

1. **Keeping the safety zone clear:** A new rule (Rule 1-2-3-d) has defined a safety zone around the field. This is intended to increase safety for players, officials and anyone else near the field of play and end zones. We still see examples of officials who allow the play to start with personnel illegally too close to the action. Why would anyone want to put themselves at risk when the rules allow the situation to be made safer? This is a critical safety responsibility and needs to be addressed. 999 times out of a 1000, someone will step back if asked by an official. The other 1 time, game management can be asked to intervene.
2. **Recognising pivotal plays:** A crew will often be remembered for a game's "pivotal plays" (MOFO 5.7). These are the moments we need to recognise and respond to in order to officiate the game effectively. The mechanics set out specific responses set out in the mechanics (MOFO 5.7.6). If these are not applied, it likely means the play was not recognised as pivotal, resulting in sub-optimal coverage. Officials must clearly communicate the outcome of the play to colleagues and, where appropriate, to nearby players and coaches. [◇]
3. **Communication when in doubt:** In this edition, we put a focus on the additional communication that is necessary between members of the crew whenever there is doubt about what happened (MOFO 5.8) (MOFO 5.10.32). Uncertainty should trigger an attempt to gain more information. This will not always work – inevitably, some plays we never know exactly what happened – but normally communication will increase both the knowledge and confidence that the crew has in its collective "call". Also, just because you are sure what happened on a play, that doesn't mean all members of the crew will be (especially the Referee). Like with pivotal plays, ensure you communicate effectively – this could be an additional or repeated signal or verbally (face to face or radio). [◇]
4. **Signalling at the end of a play:** One of the biggest giveaways that an official does not know what is happening or what they are doing is when they do not give the correct signal at the end of a play. Giving a dead-ball signal [S7], a timeout signal [S3] or an incomplete pass signal [S10] is so much a normal part of officiating that failing to do so when required is a clear sign of inexperience or poor competence. [◇]
 - (a) Officials need to focus on the basic signals (MOFO 6.5). This will make them both look more authoritative to players, coaches and spectators and more effective members of the crew.
 - (b) All officials should *always* echo *all* the timeout [S3] signals given by *any* other officials (MOFO 6.5.3).
 - (c) When covering plays out of bounds or incomplete passes, always keep your eyes on the players (MOFO 6.5.10).
 - (d) Don't be afraid to repeat a signal if you think a colleague (particularly the Referee) did not see it at your first attempt (MOFO 6.5.12).

5. **Stay at the dead-ball spot:** If you are the official covering the dead-ball spot, NEVER lose it. Stay at the spot if at all possible. If you need to move (e.g. for safety reasons), move towards/away from the sideline, not up/down the field, so that you stay on the yard line. If you absolutely need to leave the yard line, drop your bean bag before you go. Ingrain this into your way of working. If another official comes and takes over the spot from you (e.g. so that you can go speak to another official), that is OK, but they then inherit this responsibility. [◇]
6. **Relaying the ball effectively:** If you have a ball in your hand, use it effectively. If you are at the succeeding spot, put it down (unless there is a penalty to enforce). If you are a Retriever or Relayer (MOFO 6.7.1), move the ball towards the succeeding spot (normally), the dead-ball spot (if there is a flag on the play) or the previous spot (if there was an incomplete pass) (MOFO 6.7.6). [◇]
7. **Ball on ground during penalty enforcement:** The mechanics during penalty enforcement mean that, at any one time, only one ball should be on the ground (as opposed to in an official's hands). This speeds up the process and makes clear when penalty enforcement is in progress and when it has been completed. [◇]
- (a) From the end of the play until completion of penalty enforcement, the only ball on the ground should normally be at the *dead-ball spot*. The Coverer or someone who has replaced the Coverer will stand by it (MOFO 19.2.a.4). However, no ball should be placed on the ground if a forward pass was incomplete or the play ended in or through the defense's end zone.
- (b) At the end of penalty enforcement, the only ball on the ground should be at the *succeeding spot*, placed there by the Umpire or Centre Judge, normally (MOFO 19.3.3.h.iv).
- (c) At about the same time as the Umpire or Centre Judge places a ball at the succeeding spot, the ball at the dead-ball spot should be retrieved and returned to a ball person (MOFO 19.2.a.4).
- (d) Of course, if the penalty is declined, the succeeding spot may well be:
- (i) the same as the dead-ball spot (in which case the ball will not need to be moved), or
- (ii) at the inbounds spot level with the dead-ball spot (unless the dead-ball spot is less than 2 yards from the inbounds spot, two different balls should be used).
- (e) During penalty enforcement, the Umpire or Centre Judge should *hold* a ball, and *not* place one on the ground at the inbounds spot level with the dead-ball spot, as they would otherwise if the foul had not occurred (MOFO 19.3.3.d). This communicates to everyone that penalty enforcement is still in progress.
8. **Zones of coverage:** The diagrams in Chapter 26 generally show the areas of each official's responsibility at the *start* of a play. It is important for officials to remember that these change as the play develops, usually so that the nearest official is concentrating on the ball carrier and the other officials on the action around that point. Zones grow and shrink and they move up and down the field. Don't remain fixed to a static zone. [◇]
9. **Pass coverage by wing officials:** [IN xx0 FORMATION (CREW OF 4)] There has been some criticism of the change we made in the 19th edition for wing officials to remain on the line of scrimmage until a pass is thrown. The following may help explain our thinking.
- (a) A crew of 4 is inevitably a compromise (well so is 5, 6 and 7!). We took into account that most games with a crew of 4 will be lower division ones with (usually) lesser-skilled players. At that level, when you read pass, a number of things might happen:
- no pass is actually thrown – in this case the best place for the wing official is on the LoS to mark forward progress, whether it is a loss (sack) or a running gain;
 - the pass is obviously incomplete – that usually can be officiated from anywhere;
 - the pass is obviously complete but short – no problem;
 - the pass is obviously complete deeper and there is no further run – the wing official can usually get to the dead ball spot sufficiently quickly – the longer the pass, the more time it will spend in the air and thus the more time for the official to move downfield;
 - the pass is obviously complete and there is a run after the catch – in most cases the run will end in clear view and, while it may take some time for the wing official to get there, the dead ball spot will normally not be contentious because it will usually be an obvious first down.
- Those are the most common cases.
- (b) There are also some more difficult cases to officiate, including:
- when an official would be best placed to see whether the pass was caught or incomplete if they were near the end of the pass – however that can happen on a swing pass as easily as a deep pass, so there is no particular reason to be downfield for that;
 - the pass is caught and the run ends very close to the goal line – even "drifting cautiously downfield" doesn't automatically mean that an official would get to the goal line before the runner.
- Fortunately these are rare. Generally we focus our mechanics on what is best in the majority of situations and then rely on the officials to do their best in the rarer ones.
- (c) However, the main argument for keeping wing officials on the line of scrimmage was a safety one. The sooner the official is behind the play, the less likely it is that they will be run into or the ball thrown at them. Staying on the LOS gives a wing official the best chance of having a wide field of view that includes both the QB (out of the corner of one eye) and all the receivers (either in the middle of vision, or in the corner of the other eye).

We hope that clarifies things.

Previous points of emphasis are also still relevant:

10. **Process at end of first and third quarters:** Do not be in a hurry to change ends. Wait until everyone has properly recorded the information they need before moving to the other end of the field (MOFO 20.4.2). [×]

11. **Speeding up free kicks:** There should not be any significant delay in kicking off after a score. All officials should jog to their free kick positions. The Umpire should hand the ball to the kicker or leave it near the kickoff spot. Once all officials are in position, the Umpire can signal to the Referee and the Referee should promptly declare the ball ready for play. It should never be an issue of waiting for the kicking team to be ready. They have 25 seconds to get ready and kick the ball after the ready for play.
12. **Penalty administration:**
- If you have thrown your flag, make sure you give a long, clear timeout signal at the end of the play (MOFO 19.1.b.2). Other officials will echo this. Make sure the Referee, Umpire and Centre Judge are aware of your signal.
 - Unless you are holding the dead-ball spot, once continuing action has ended, go to the Referee to report your foul (MOFO 19.1.b.5.a). [USING O2O/CREW RADIO] Transmit the details of the foul so that everyone is aware (MOFO 19.3.3.h.ii).
 - [UMPIRE OR CENTRE JUDGE] Ensure you know as soon as possible the reason for a flag being thrown (MOFO 19.2.a.6).
 - If you have information to contribute to penalty administration (e.g. you thought the pass was uncatchable on DPI; you know there was a change of possession and are not sure the Referee does), pass it on (MOFO 19.2.a.3).
 - If your flag is for targeting, you must have direct, verbal communication with at least one other official prior to reporting the foul to the Referee (MOFO 19.1.b.8).
13. **Whistle:** It is never wise to carry your whistle in your mouth. It is too easy to blow an inadvertent whistle (MOFO 6.4.5).
14. **Concussion:** Pay particular attention to participants (players and officials) who may have suffered a concussion (MOFO 6.2.6.e).
15. **Game clock at the end of a half:**
- Be particularly aware of the time remaining and the status of the clock during the last few minutes of a half, especially the second half when the game is close.
 - By rule (Rule 3-3-9-b), everyone is entitled to know the time remaining every occasion that the clock stops during the last two minutes of each half. The crew must be proactive in sharing this information unless there is a visual game clock. This responsibility starts with the timekeeper and includes the officials nearest the Team A and Team B huddles, and the officials nearest the Head Coach of each team (MOFO 20.3.2). [USING O2O/CREW RADIO] Using radios to share clock information is mandatory (MOFO 25.3.1).
 - Anticipate when the Head Coach of a team might want to call a timeout after a play ends. Be prepared to look towards the Coach if you can do so without taking your eyes off important action in front of you.
16. **Clock when a ball carrier goes out of bounds:** If the ball carrier is pushed backwards or sideways out of bounds, the clock continues to run, because their *forward* progress was stopped inbounds (Rule 4-1-3-a).
17. **Umpire and Centre Judge mechanics around ready for play:**
- The Umpire and Centre Judge should be in their position (not standing over the ball) prior to the snap unless any of the conditions of 10.9.c.14 apply.
 - The Umpire or Centre Judge should immediately get over the ball if a whistle is blown for any reason (e.g. a foul occurs, a timeout is granted, the ball blows away), or if Team A makes a last second substitution (MOFO 9.9.c.7.g and 10.9.c.16).
 - Whichever official spots the ball, there is no reason for anyone to stand over it unless something delays play.
18. **Sideline communication:** The following items of communication between the officials and the Head Coach of a team are essential:
- For each foul against their team, the nearest sideline official must inform the Head Coach of the number or position of the offending player and what the player did that was illegal (MOFO 19.3.10). If the enforcement involves loss of down, the Coach must be informed of this also.
 - For each unusual enforcement or judgement, an official must inform both Head Coaches, whether or not it is against their team (MOFO 19.3.10). This may be the nearest sideline official or the Referee, depending on the nature of the call.
 - "If a visual game clock is not the official timing device during the last two minutes of each half, the Referee or their representative shall notify each captain and Head Coach of the time remaining each time the clock is stopped by rule" (Rule 3-3-9-b). This will normally be relayed to the Head Coach via the nearest sideline official.
 - At the two-minute warning, the nearest sideline official must inform the Head Coach of the *precise* time remaining and how many timeouts each team has remaining.
 - When a team has used its *final* timeout of a half, the Referee must inform the Head Coach of this fact, as well as the precise time remaining. The Referee should *not* delegate this job to another official.
 - When a player is disqualified, the Referee accompanied by the official who called the foul (or the nearest sideline official if it was the Referee) must inform the Head Coach of the number of the player disqualified and the nature of the foul (MOFO 19.1.b.11). ^x
19. **Out of bounds coverage:** When the ball carrier goes out bounds, the covering official *must* turn and keep their eyes on them while there is a threat of action against them (MOFO 6.3.1).

2. CHANGES TO MECHANICS

This edition of the *Manual of Football Officiating* has been updated to add new material and to better organise what we already had. This edition is an update on the [19th edition](#) that sets out to clarify and enhance existing mechanics and to introduce new ideas about football officiating.

Major changes or new sections are marked by a box like this. [New or modified text is marked in blue \(grey when printed in monochrome\).](#)

The changes embodied in this edition have come from a number of sources, including:

- issues discussed at international clinics and tournaments in recent years;
- annual NCAA/CFO announcements on rule interpretations and philosophies;
- the views of an international advisory group (see the foreword for a list of those involved).

2.1 - Major changes

The following is a list of the most important additions and changes:

Announce live-ball fouls before dead-ball ones	19.3.8.f
Brief punt returners on fair catch signals	8.2.10.e, 8.2.11.d
Brief QBs and kickers on play clock	8.2.6.e
C6 reaction to blocked field goals	9.8.d.4.b
C6 reaction to change in field goal formation	9.8.d.4.c
Charging timeouts for injuries	3.9.60, 6.2.6.h, 9.9.c.6.a, 10.9.c.12.a
Deep officials to read play before moving	12.2.c.4, 12.3.b.1, 12.4.b.2, 15.2.c.4, 15.3.b.1, 15.4.b.2
Details of foul to be recorded	6.11.3
F responsible for balls pre-game on 6D	8.1.7, 8.2.11.a, 8.4.3.c.iii
Give normal timing signals during a running clock session	6.5.6
Half-time procedures	20.5.1
Inadvertent whistle mechanics	6.15
Inadvertent whistle philosophies	3.8.7, 3.9.46
New points of emphasis	1.3.1, 1.3.2, 1.3.3, 1.3.4, 1.3.5, 1.3.6, 1.3.7, 1.3.8
New points to ponder	5.9.41, 5.9.42
New principles	5.10.16, 5.10.32, 6.1.14, 6.4.13
New when in doubt principles	3.9.56, 3.9.57, 3.9.58
Notify colleagues when pre-game duties completed	8.2.15
Noting eligible receivers on field goal attempts	9.8.d.4.a, 10.8.d.1.b, 11.8.d.2.d, 12.8.d.2, 13.8.d.1.b, 14.8.d.1, 15.8.d.1
Officials must bear scrutiny	5.2.3, 5.2.4
R and C positioning	9.2.b.2, 9.2.b.3, 9.2.b.4, 9.7.b.1
R/C/U note numbering exceptions	9.7.a.1, 9.8.a.1, 10.7.a.1, 10.8.a.1
Record result of coin toss	8.4.7.c, 8.4.14
Revised timeout mechanics	17.1.9.a, 17.1.10, 17.1.11, 17.2.3, 17.2.5
Sideline official must notify coach of time remaining	20.2.3
Starting position out of bounds	11.2.b.2, 11.5.b.1, 13.2.b.2, 13.5.b.1, 14.2.b.3, 14.5.b.1
Use radio when discussing face to face	6.4.10.a, 25.4.9

In these sections, and elsewhere, the following symbols are used to denote the reason for a change:

†	mechanic changed for better coverage
§	fill gap in existing mechanic
◇	clarification or enhancement of existing mechanic
@	change for better communication
×	previous text deleted
®	change due to rule change
λ	editorial correction/clarification or text moved

The change mark normally *follows* a change, except where there is a completely new list, in which case the change mark will be at the end of the paragraph introducing the list.

2.2 - Editorial changes

Editorial changes (those intended to clarify the presentation of particular points, fill gaps in existing guidance, improve coverage or resulting from rules changes) are listed below.

The position previously known as Linesman is now referred to as Down Judge. Changes have been marked but do not appear in this list unless something else has also changed in that item.

Chapters 3, 5 and 6 have had some of their contents reorganised.

- The "When in doubt" principles (previously in Chapter 6, "Axioms of Officiating") have moved to Chapter 3, Rules Application. This is because they form part of the way rules are interpreted.
- Chapter 5 ("General principles") has gained the remainder of the old Chapter 6, but lost those sections which were not so much principles as "General mechanics" - these are now Chapter 6. This is because we wanted to separate "principles" (what you think) from "mechanics" (what you do).

Text that has moved (but remains otherwise unchanged) is not marked as a change.

1.1.3	3.4.3.a	3.9.12	8.1.4	9.9.a.13
1.1.5	3.4.3.d	3.9.13	8.2.3	9.9.c.1
1.2.1	3.4.3.f	3.9.29	8.2.9.b	9.9.c.7.e
1.2.10	3.4.3.g	3.9.36	8.2.14.b	9.9.c.12.a.ii
1.3.9	3.4.3.h	3.9.39	8.3.3.d	9.9.c.12.b.ii
3.1.1	3.4.4	3.9.40	8.3.4.d	9.9.c.12.b.iii
3.1.7	3.4.5.a.iv	3.9.41	8.3.4.g	9.9.c.13.a
3.3.1.a	3.4.5.c	3.9.54	8.4.1	9.9.c.13.b
3.3.1.a.ii	3.4.5.e	4.1.17	8.4.3.a	9.9.d.2.b.ii
3.3.1.b.iii	3.4.6.a	5.1	8.4.3.b	9.9.d.2.b.iv
3.3.1.d	3.4.6.c	5.3.2	8.4.2	9.9.d.2.c.i
3.3.1.d.i	3.4.7	5.3.3	8.4.11.e	9.9.d.2.c.ii
3.3.1.d.iii	3.4.9.c	5.5.2.a	8.4.13	9.9.d.6
3.3.2.c	3.4.9.d	5.10.18	8.4.15	10.1.a.4
3.3.2.e	3.4.9.e	5.10.22	9.1.a.4	10.1.a.7.b
3.3.2.g	3.4.10.c	6.2.5	9.1.a.5.b	10.1.a.7.c
3.3.2.h	3.4.10.f	6.2.6.c	9.1.a.5.c	10.1.a.10
3.3.3	3.4.11.d	6.2.6.d	9.1.a.5.d	10.1.a.11
3.3.4.e	3.4.11.e	6.2.7.h	9.1.a.8	10.1.a.14.m
3.3.5	3.4.11.f	6.2.8	9.1.a.10	10.1.b.3
3.3.5.f	3.4.16.a	6.2.10	9.1.a.12	10.1.c.1
3.3.5.h	3.4.16.b	6.2.13	9.1.a.14.g	10.1.c.6
3.3.5.j	3.4.18.a	6.2.16.e	9.1.b.1.b	10.1.c.7.b
3.3.6.a	3.4.19	6.2.17	9.1.b.4.b	10.1.d.3
3.3.6.b	3.5.1.a	6.3.3	9.1.c.6.a	10.2.a.3
3.3.6.d	3.5.1.c	6.3.5	9.1.c.6.d	10.2.a.4
3.3.8.a.iv	3.5.1.d.ii	6.3.6.d	9.1.c.7	10.2.a.10.b
3.3.8.b.vi	3.5.3.c	6.4.5	9.1.c.7.b	10.2.a.10.c
3.3.8.c.ii	3.5.4.c.v	6.4.10.g	9.1.c.9.a	10.2.a.12
3.3.8.c.vi	3.5.4.c.vi	6.4.11	9.1.d.1	10.2.a.14
3.3.8.c.vii	3.5.4.d.iv	6.4.12	9.1.d.2.c	10.2.a.15
3.3.8.c.vii.2	3.5.5.d	6.5.7	9.1.d.3	10.2.c.3
3.3.9.a.iv	3.5.5.f	6.5.14	9.2.a.3	10.2.c.5
3.3.9.b.iv	3.5.7.b	6.5.14.b	9.2.a.4	10.4.a.4
3.3.9.b.v	3.5.7.c	6.5.15	9.2.a.11.b	10.4.c.5
3.3.9.b.vi	3.5.9	6.5.18	9.2.a.11.c	10.6.a.4
3.3.10.c	3.5.11	6.6.5.a	9.2.a.13	10.7.a.2.a
3.3.10.d	3.7.2	6.7.3	9.2.a.14	10.8.a.2.a
3.3.10.e	3.8.1.c	6.7.5	9.5.b.1.a	10.8.a.2.c
3.3.12.e	3.8.2.b	6.7.6.b	9.6.a.4	10.8.c.4
3.3.13.a	3.8.3	6.7.7	9.6.b.3	10.9.a.11
3.3.14.a	3.8.4	6.7.8.b	9.7.b.2	10.9.c.1
3.3.14.c.ii	3.8.4.a.ii	6.7.8.d	9.8.b.1	10.9.c.15
3.3.14.c.ii.1	3.8.5.b	6.10.3	9.8.b.1.a	10.9.d.2.b
3.3.15.a	3.8.5.e	6.10.6	9.8.b.1.b	10.9.d.2.c
3.3.17.a	3.8.5.e.i	6.11.1	9.8.b.1.c	10.9.d.8
3.3.17.c	3.8.5.e.ii	6.12.2.a	9.8.c.1	11.1.a.4
3.3.17.d	3.8.6.c	6.12.2.b	9.8.c.2	11.1.a.5.b
3.3.17.e	3.8.6.f	6.12.4	9.8.c.2.a.ii	11.1.a.5.d
3.3.18.a	3.8.7.e	6.13.3	9.8.c.2.b.iii	11.1.a.9
3.4.1.d	3.9.8	6.14.4.j	9.8.d.1.a	11.1.a.10
3.4.1.e	3.9.9	8.1.1	9.8.d.1.c	11.1.a.13.i
3.4.1.f	3.9.10	8.1.2	9.8.d.4.b.ii.2	11.1.b.2
3.4.3	3.9.11	8.1.3	9.8.d.5	11.1.b.3.a

11.1.b.3.b	12.9.c.3.c	14.8.d.2.b.ii	19.3.2.a
11.1.c.5.a	12.9.c.4	14.9.b.1	19.3.3.f
11.1.c.5.d	13.1.a.3	14.9.b.2	19.3.3.h.iv
11.1.c.6	13.1.a.4.b	14.9.b.3	19.3.5.c
11.1.d.1	13.1.a.4.c	14.9.b.7	19.3.8.a
11.1.d.2	13.1.a.8	14.9.b.9.a	19.3.8.g
11.2.a.3	13.1.a.9	14.9.b.9.e	19.3.8.h.ii
11.2.a.4	13.1.a.13.h	14.9.b.13.b	19.3.8.h.iv
11.2.a.16	13.1.b.1	14.9.c.2.c	19.3.8.i
11.2.a.17	13.1.b.2	14.9.c.3	19.3.9
11.2.a.19	13.1.c.5	15.1.a.3	20.1.7
11.2.c.3	13.1.c.9	15.1.a.4.b	20.2.1
11.2.d.4	13.1.d.1	15.1.a.4.c	20.3.1
11.2.d.6	13.1.d.2	15.1.a.4.d	20.3.2
11.3.a.5	13.2.a.2	15.1.a.9	20.3.4
11.3.b.3.e.iii	13.2.a.3	15.1.a.10.j	20.3.6
11.4.a.4.f	13.2.a.16	15.1.c.4	20.5.5.a
11.4.a.5	13.2.a.17	15.1.d.2	20.6.5
11.4.a.6	13.2.a.19	15.1.d.3	20.7.1
11.4.b.2	13.2.c.3	15.2.a.7	20.7.2
11.4.b.7	13.2.d.4	15.2.b.4	20.7.3.c.v.3
11.4.b.12	13.3.a.5	15.4.b.10	21.2.1.c
11.5.c.6	13.3.b.3.e.iii	15.5.a.1	21.2.1.j
11.5.c.8	13.4.a.3.f	15.5.c.3	22.1.10
11.5.d.2	13.4.a.6	15.6.a.4	22.1.12.b
11.5.d.5	13.4.b.2	15.7.b.5	22.1.12.d
11.6.a.5	13.4.b.7	15.7.c.3.f	22.1.12.e
11.7.b.5	13.4.b.12	15.7.d.3.b	22.1.13
11.7.c.7.g	13.5.c.6	15.8.b.1	22.1.16
11.7.d.2.b	13.5.c.8	15.8.c.3	22.1.17.c
11.7.d.2.e	13.5.d.3	15.8.d.2.b.ii	22.1.17.f
11.8.a.3.h	13.5.d.7	15.9.b.1	22.1.17.g
11.8.b.2	13.6.a.5	15.9.b.2	22.1.18
11.8.c.1.c	13.7.b.2	15.9.b.3	22.2.1
11.8.d.2.f	13.7.b.4	15.9.b.7	22.2.3
11.9.c.1	13.7.d.1.b	15.9.b.10	22.2.4
11.9.c.2	13.7.d.1.e	15.9.c.2	22.3.9
11.9.c.3	13.8.b.2	15.9.c.3.c	23.2.2
11.9.c.8	13.8.d.1.d	15.9.c.4	24.2.1.a
11.9.c.11.a	13.9.c.1	16.1.1	24.2.2
11.9.c.11.e	13.9.c.2	16.1.2.c	24.2.8
11.9.d.2.c	13.9.c.3	16.2.4	24.3.5
11.9.d.3	13.9.c.8	17.1.8	24.4.6
12.1.a.3	13.9.c.11.a	17.1.9.b	24.5.6
12.1.a.4.b	13.9.c.11.e	17.1.9.b.ii	24.5.7
12.1.a.4.c	13.9.d.2.c	17.1.9.e	24.5.10
12.1.a.4.d	13.9.d.3	17.2.4	24.5.13.b
12.1.a.8	14.1.a.3	17.2.7	24.5.13.c
12.1.a.9	14.1.a.4.b	17.2.8.a	24.5.14
12.1.a.10.j	14.1.a.4.c	18.3	24.6.3.b
12.1.d.2	14.1.a.4.d	18.10	24.6.4.a
12.2.a.7	14.1.a.9	18.13	24.7.3
12.2.d.4	14.1.a.12.j	18.16	24.7.3.e
12.4.b.10	14.1.b.5.a	19.1.b.2.a	24.8.1.b
12.5.c.3	14.1.c.5	19.1.b.4.c	24.8.3.b
12.6.a.4	14.1.d.3	19.1.b.7	25.1.1
12.7.b.5	14.2.a.8	19.1.b.7.b	25.1.3
12.7.c.3.f	14.4.b.10	19.1.b.11.f	25.1.6
12.7.d.2.b	14.4.b.14	19.1.b.12	25.3.6
12.8.b.1	14.5.b.15	19.1.c.2	25.4.8.c
12.8.c.3	14.5.c.4	19.2.a.4	26
12.8.d.3.b.i	14.6.a.5	19.2.b.2	26.2.J
12.9.b.1	14.7.b.1.a	19.3.1.a	27
12.9.b.2	14.7.b.6	19.3.1.c	
12.9.b.3	14.7.c.3.g	19.3.1.d	
12.9.b.7	14.7.d.3.b	19.3.1.d.ii	
12.9.b.10	14.8.a.2.a.ii	19.3.1.e	
12.9.c.2	14.8.c.1.c	19.3.1.e.i	

3. RULES APPLICATION

Foreword

Nobody wants to see a game where every minor infraction is penalised. This would much lengthen the duration of games and make the playing and spectating experience intolerable.

Historically, officials have used their experience to judge what is appropriate to flag and what not to flag. However, to leave that to each official's individual discretion would be to make the officiating of games too inconsistent. Hence we need guidelines to operate by.

These guidelines have appeared in Chapter 3 of each edition of the Manual of Football Officiating since 1993 and are widely accepted as being the appropriate philosophy for officiating American football. They are based on standards issued by the Collegiate Commissioners Association (for NCAA football) and revised by senior international officials with input from experienced coaches.

They are now in the rulebook to facilitate wider education about the principles under which the game is officiated. In any particular game, coaches and/or players should not expect that the rules are interpreted differently than described here. The referee's decision remains final.

[note:] This version of the Rules Application is duplicated in both the 2026 IFAF Rulebook and the 20th edition of the Manual of Football Officiating. In future, updates will appear in the Rulebook and will supersede those in past editions of the MOFO. §

3.1 - Introduction and principles

1. These philosophies[°] apply in full competitive adult games.
2. A stricter interpretation is appropriate in games involving junior/youth players and/or where the players are all obviously inexperienced.
3. A stricter interpretation is also appropriate in games where player conduct or attitude in general (i.e. not just one or two players) threatens to escalate the number or type of fouls committed. This may include clamping down on "minor" fouls when frustration may lead to "major" fouls.
4. A less strict interpretation of the rules is appropriate in blowout games when one team has a large lead and is obviously dominant. However, this should not extend to ignoring safety-related or conspicuous fouls.
5. Fouls in the open field are conspicuous enough to need calling whether or not they affect the play.
 - (a) It is likely that you will lose credibility if you do not call these.
 - (b) Our philosophy has moved from "did it affect the play?" to "was it conspicuous?". This reflects that more and more people watch games on video and therefore see things differently than if they are in the stands or on the side of the field.
 - (c) A less conspicuous foul still merits consideration of whether or not it affected the play. Major fouls (those that carry a 15-yard penalty or similar) should always be called.
6. If a flag is thrown for a foul where these principles indicate that it should not have been, the penalty should still be enforced. Generally, don't wave a flag off, once thrown, if it signifies a foul by rule.
7. Also bear in mind section 5.1 of the Manual of Football Officiating[§] on common sense officiating.
8. Where a rule is not mentioned in this chapter, apply philosophy consistent with the following principles:
 - (a) Fouls affecting player safety should always be called.
 - (b) Fouls that are conspicuous should be called.
 - (c) Fouls that give a team or a player a clear advantage should be called.
 - (d) Fouls that are minor/technical and probably unrealised by the players should result in a "talk to" for a first offence.
9. When we talk about gaining an advantage (or disadvantaging an opponent), pragmatically you probably have to make that decision within a couple of seconds of seeing the action. Waiting longer means that you might miss other action that you are responsible for and/or lose the spot of the foul.

3.2 - Definitions

1. **Point of attack** is defined as follows:
 - (a) on a running play, it is the area in advance of the ball carrier – if they change direction the point of attack changes;
 - (b) on a forward pass play, it is anywhere in the vicinity of the passer or any player attempting to reach the passer, or in the vicinity of any eligible receiver running a pass route;
 - (c) on a scrimmage kick play, it is anywhere in the vicinity of the kicker or returner or any player attempting to reach the kicker or returner, or block the kick.
2. **Conspicuous**: An action is "conspicuous" if it would be visibly apparent to a spectator who knew the rules or to an official observing the game live or watching it on video. Generally, anything that takes place in the open field, or by a player standing alone, is conspicuous; anything that takes place in close line play or in a pile-up is not conspicuous. Examples of conspicuous fouls that should be called, even though they might otherwise be disregarded as "not serious", include:
 - (a) **takedown holding** (especially in the tackle box);
 - (b) **blocks in the back** in the open field;

- (c) **illegal substitution** when a player leaves the field other than across their own sideline;
 - (d) **illegal substitution** when a team has 12 or more players in the huddle for more than 3 seconds (but don't nit pick the 3 second limit);
 - (e) **intentional illegal touching** of a forward pass;
 - (f) **false start** by a back, tight end or wide receiver;
 - (g) **offside** by Team B at their restraining line on a short free kick;
 - (h) **free kick out of bounds**.
3. **Brick in hand:** We sometimes use this term to refer to a player who we want to watch closely. Its origin is that if you saw someone outside a jeweller's window with a brick in their hand, you would be suspicious of what they would do next, and you would want to keep watching them to see if they threw it. Examples include: when you see an offensive player chasing a defensive player, you might expect to see an illegal block in the back; when you see a player approaching an opponent at speed, you might expect to see an illegal blind-side block.

3.3 - Contact fouls

1. Offensive holding:

- (a) Only call it when *all* of the following conditions are met:
 - (i) the foul **is visibly apparent**, i.e. *it would show up on video*²
 - (ii) the foul **affects the play or is conspicuous**, i.e. *it is clearly at the point of attack or is conspicuous*,² *bearing in mind that the closer to the point of attack it is, the less it takes for it to need calling*;[§]
 - (iii) the action **is demonstrably restrictive**, i.e. *the player is illegally slowed down or forced to take a longer route to their target*;²
 - (iv) the foul **disadvantages the opponent**, i.e. *it actually moves the player opposite the way they want to go*.²
- (b) Actions that constitute offensive holding include:
 - (i) **Grab and restrict** – grabbing the opponent's body or uniform in a manner that restricts their ability to go in the direction they wish to go.
 - (ii) **Hook and restrict** – hooking a hand or arm around the opponent's body (beyond the frame of the body presented to the blocker) in a manner that restricts their ability to go in the direction they wish to go.
 - (iii) **Takedown** – taking an opponent to the ground *by grabbing or hooking*² when they don't want to go to the ground. Note that it is *completely legal to push or otherwise*[◊] block an opponent to the ground, provided the hands or arms are used within the frame of the opponent's body (or in the back in the free-blocking zone).
- (c) A player is **restricted** if:
 - (i) They are unable to turn or change direction due to continued, restrictive contact.
 - (ii) Their upper body is turned by the blocker having their arms around them.
 - (iii) They are unable to gain separation or to disengage from the opponent by turning, twisting, stopping, etc.
 - (iv) Their balance is changed or their natural foot movement is taken away.
- (d) *In the following circumstances, no advantage is typically gained*, so normally don't call holding if *any* of the following conditions are met, unless the foul is really conspicuous:
 - (i) the held player makes the tackle *behind the neutral zone, or when the ball carrier made no extra yards as a result of the hold*;[◊]
 - (ii) the held player knocks down or intercepts a pass;
 - (iii) the held player *catches or* recovers a fumble;
 - (iv) at the point of attack on a run, the opponents are squared up, moving with each other and none of the restrictions above are noted;
 - (v) it happens at the same time as a tackle elsewhere on the field;
 - (vi) it is behind the neutral zone and a forward pass has already been thrown, or is in the process of being thrown;
 - (vii) it is part of a double-team block (unless a takedown occurs, or the defender breaks the double team and is pulled back);
 - (viii) it is the result of a defensive rip, i.e. the defensive player raising the offensive player's arm;
 - (ix) the held player makes no effort to get free of the block, i.e. they "give up".
- (e) Holding an opponent's jersey is *not* the same as holding the opponent. For a jersey pull to be a foul, there must be demonstrable restriction to the player's movement.
- (f) Watching the *disengagement* of opponents is as important as watching their engagement. If a defender slides off a block and is able to proceed normally in the direction they want to travel (usually towards the ball), then it is unlikely that holding has occurred.

2. Defensive holding:

- (a) Downfield on pass plays, everywhere is the point of attack – a foul on an eligible receiver can occur anywhere.
- (b) Always call fouls that prevent the passer throwing the ball and lead to a sack.

- (c) A clothesline block (or *clotheslining*) is usually made by a defender against an opponent (typically an eligible receiver) who is running at speed. The defender sticks out an arm as the opponent approaches, causing the opponent to run forcibly into the arm (typically forearm) at head or neck height, i.e. above the frame of the body (Rule 2-3-5). This should be called as a personal foul (and normally as targeting with the indicator being leading with the forearm).[§]
- (d) Contact that does not demonstrably impede a receiver should be ignored.
- (e) A grab of the receiver's jersey **before a pass is thrown**[§] that restricts the receiver and takes away their feet should be called. **A grab after the pass is thrown is defensive pass interference if the ball is catchable by the fouled receiver.**[§]
- (f) Holding should be called against defenders who clearly *illegally* restrict an offensive player from making a lead block for the ball carrier (this includes pulling linemen on trap and sweep plays), but not where the offensive player is too far away from the play to become involved.
- (g) Defensive holding should *not* be called for contact that occurs after the pass is thrown to the opposite side of the field (unless it is a clear attempt to restrict an offensive player as in (f) above). However, if the foul occurs anywhere while the quarterback still has the ball and is looking to pass, then call it, even though the ball might eventually be thrown elsewhere **or the quarterback sacked.**[§] This could have had an effect on the play. The timing of the hold is important.
- (h) **Defensive holding should *not* be called for contact that occurs against an eligible receiver on the opposite side of the field to a designed running play. A foul may still be called if the run results from being unable to pass to the held receiver.**[§]

3. **Illegal use of hands:**

- (a) **Apply the same conditions**² as for offensive holding.
- (b) If the initial contact in a block is on the opponent's **helmet, face mask or neck**[§] for more than a brief second, it should^x be called as a personal foul. **If the contact lasts a shorter time, it is probably illegal use of hands.**[◊]
- (c) Make sure you see the initial contact: it is not a foul if a player's hands slide up to a point above the opponent's shoulders.

4. **Blocks below the waist and clipping:**

- (a) When in **doubt**,² the ball has not left the free-blocking zone (for blocks from the back).
- (b) For the first three seconds after the snap, when in **doubt**,² the ball has not left the tackle box (for blocks from the front). Thereafter, when in **doubt**,² the ball *has* left the tackle box.
- (c) To call clipping, you need to see two things:
 - (i) the blocker's last stride before the contact (so that you are fairly certain you know which direction they came from), *and*
 - (ii) you need to have seen the opponent they hit before the block (so that you know whether the opponent turned their back or not).

You must see the point of initial contact. Remember that contact to the side is **not clipping - it is covered by the blocking below the waist rule.**[®] See the entire act.

- (d) Remember that it is the direction related to the opponent's area of concentration (not the point of contact) that determines whether a block below the waist is "directed from the front" or not.
- (e) It is not a foul for a block below the waist or clip if the contact occurs because the blocker **unintentionally**[§] slips or falls down and the opponent runs into them.

5. **Illegal block in the back:**

- (a) **Apply the same conditions as for offensive holding,**² but also apply the conditions for calling clipping, particularly the need to see the entire act.
- (b) **In particular, blocks in the back that occur at or about the same time as the ball carrier is being tackled should not be called, unless they rise to the level of a personal foul.**[◊]
- (c) **When a maul has formed around the ball carrier (defensive players trying to tackle the ball carrier and offensive players trying to prevent them from doing so), this does not give anyone licence to block in the back. Blocks in the back of defensive players by offensive players should be called if the force from the contact moves the maul significantly forward or constitutes a personal foul.**[§]
- (d) If one hand is on the **opponent's**² number and the other hand is on the side and the initial force is on the number, it is a block in the back.
- (e) A block that starts in the side and ends up in the back is not a foul as long as there is continuous contact.
- (f) Touching an opponent in the back is not a foul unless it results in them being knocked down or pushed off balance sufficiently so that they stumble, misstep **or are pushed past the ball carrier**[§] *and* miss making a tackle or block. Remember, the foul is for illegal *block* in the back, not an illegal *touch* in the back.
- (g) **Do not call an illegal block in the back on a fair catch if the illegal block occurs away from the play as the fair catch is being made, or the play results in a touchback. Personal fouls (such as unnecessary roughness or blind-side block) should always be called.**[§]
- (h) Charging into a player's back^x may be called as unnecessary roughness **or as an illegal blind-side block.**[§] This may be called regardless of the timing of the block relative to the end of the play.
- (i) Be particularly alert when you see an offensive player chasing a defensive player (and vice versa when the defensive player is not attempting to reach the ball). Imagine they have a brick in their hand. **When in "chase" mode, all action must be from the side to be legal.**[§]

- (j) A block in the back by a defensive player against a trailing offensive player is either a personal foul for unnecessary roughness, an illegal blind-side block or it is nothing. §

6. **Roughing the passer:**

- (a) If the defensive player's main contact is on the passer's head,[‡] it is always a foul unless the passer ducks into it or the contact is slight. However, it is only targeting if the contact goes well beyond making a legal tackle or attempting to block/deflect the pass.
- (b) Contact at the knee area or below on an offensive player in a passing posture is enforced according to Rule 9-1-9-b. Slight contact should be disregarded. Don't be picky about the knee area - anywhere in the vicinity of the knee is a foul. ◊
- (c) It is a foul if a defender (in front of the passer) takes two steps before contacting the passer after the ball has been thrown/released. A defender behind the passer is given a little more leeway.
- (d) Defensive players who make a legitimate attempt to avoid or reduce contact are given the benefit of the doubt. A soft hit can still be a foul, if it is really late. (The later the hit, the lower the threshold of force needed to make it a foul.) Any second act (distinct from the initial charge) is likely to be a foul. §
- (e) When in doubt, it is roughing the passer if the defender's intent is to punish.
- (f) When considering roughing the passer fouls, there are four possibilities:
- (i) The contact is high (to the passer's head/neck area); timing doesn't matter. This will be a foul either for targeting (if the conditions for that are met) or for roughing the passer (forcible contact to the head/neck that doesn't rise to the level of targeting).
 - (ii) The contact is low; timing doesn't matter. The player must be in passing posture. Forcible contact to the knee area or below is a foul.
 - (iii) The contact is late; doesn't matter where on the passer's body. Contact after the pass is released that is punishing or avoidable is a foul.
 - (iv) Contact that is not punishing or forcible; even if high/low/late. This is not a foul.

7. **Roughing/running into the kicker:**

- (a) Generally, contact with the kicker's kicking leg will be considered as *running* into the kicker, and contact with their plant leg (even if it is off the ground) will be considered as *roughing* the kicker.
- (b) Any time the kicker or holder are knocked off their feet it should be called as *roughing*.
- (c) Where the kicker makes a move before the kick that is not part of the normal kicking motion, then it is no longer obvious that a kick will be made and there will probably be no foul unless the defensive player is out to punish them. Note that "rugby-style" kickers (those who kick on the run) are entitled to as much protection as conventional kickers after they have kicked the ball. But any contact with a kicker before the kick is simply tackling a ball carrier.
- (d) Even if the snap is bad, a kick may still be obvious. Provided the kicker or holder gathers the ball and straight away goes into their normal motion, then they are entitled to protection (always assuming the ball is kicked). **Exception:** if the kicker carries or possesses the ball outside the tackle box or more than 5 yards behind their initial position. ®

8. **Defensive pass interference:**

- (a) Actions that constitute defensive pass interference include:
- (i) **Not playing the ball** – Early contact by a defender (who is not playing the ball) that impedes or restricts the receiver's opportunity to make the catch.
 - (ii) **Playing through an opponent** – Playing through the receiver (i.e. contacting them in the back or on the side of them furthest from the ball), whether or not the defender is playing the ball.
 - (iii) **Grab and restrict** – Grabbing the receiver's arm in a manner that restricts their opportunity to catch a pass.
 - (iv) **Arm bar** – Extending an arm across the receiver's body to impede their ability to catch a pass, whether or not the defender is looking for[◊] the ball.
 - (v) **Cut off** – Cutting off or riding a receiver out of the path to the ball by making contact with them without playing the ball (i.e. before the defender looks for the ball).
 - (vi) **Hook and turn** – Hooking a receiver around the waist that causes their body to turn prior to (or even slightly after) the ball arriving (even if the defender is trying to get to the ball).
- (b) Actions that do *not* constitute defensive pass interference include:
- (i) Incidental contact by a defender's hands, arms or body in the act of moving to the ball that does not materially affect the route of the receiver. If in doubt as to whether the route was materially affected, there is no interference.
 - (ii) Inadvertent tangling of feet when both (or neither) players are playing the ball.
 - (iii) Contact occurring during a pass that is clearly uncatchable by the involved players.
 - (iv) Laying a hand on the receiver that does not turn or impede them until after the ball has arrived.
 - (v) Contact on a "hail mary" pass unless it is clear and conspicuous pass interference.
 - (vi) Any action by a Team B player who is not aware of where the Team A player is. It is absolutely a requirement for DPI that there is obvious intent to impede. ◊
- (c) Further notes:
- (i) A stationary player (in position to catch the ball) who is displaced from their position has been fouled.
 - (ii) It is never pass interference if any player touches the ball before the defender contacts[‡] the opponent.

- (iii) Interference must be conspicuous to be called.
- (iv) Remember that the defense has as much right to the ball as the offense.
- (v) It is crucial to identify which players are playing the ball and which are not.
- (vi) Normally, an offensive receiver will try to catch the ball with two hands. **If the receiver goes up with only one hand, is that because their other hand has been illegally obstructed?** [◇] Often, a defender will try to bat/deflect the ball with only one hand. If the defender goes up with only one hand, **know whether the other hand is doing something illegal.** [◇]
- (vii) **Uncatchable pass:**
 - (1) When judging whether a pass is catchable, imagine how far the receiver could have run, and how high or wide they could have jumped, if they had not been impeded. The earlier the contact, the further the receiver could have moved towards the end of the pass.
 - (2) An uncatchable pass must be obviously uncatchable in order to disregard a foul for pass interference. [◇]
- (viii) There is no foul when contact is simultaneous with the ball being touched ("bang-bang"). When in doubt, contact is simultaneous with the ball being touched.

9. Offensive pass interference:

- (a) Actions that constitute offensive pass interference include:
 - (i) **Pushing off** – Initiating contact with a defender by shoving or pushing off, thus creating a separation in an attempt to catch a pass.
 - (ii) **Driving through** – Driving through a defender who has established a position on the field.
 - (iii) **Blocking** – Before the pass is thrown, blocking that occurs anywhere down field. After the pass is thrown, blocking that occurs down field within approximately 20 yards (more if the pass is delayed) of where the pass is thrown to.
 - (iv) **Pick** – Picking off (initiating contact with) a defender who is attempting to cover a receiver. **Remember that intent to impede is not necessary for offensive pass interference - it is sufficient that the defender was interfered with.** [§] It is not a foul if the contact occurred at the same time as the pass was touched.
- (b) Actions that do *not* constitute offensive pass interference include:
 - (i) Incidental contact by a receiver's hands, arms or body in the act of moving to the ball that does not materially affect the route of the defender. If in doubt as to whether the route was materially affected, there is no interference.
 - (ii) Inadvertent tangling of feet when both (or neither) players are playing the ball.
 - (iii) Contact during a pass that is clearly uncatchable by the involved players.
 - (iv) Blocking downfield when the pass is legally grounded out of bounds or near the sideline. **(Exception: Blocking downfield can still be called if the forward passer is legally grounding the ball other than out of bounds or near the sideline.)** [◇]
 - (v) **When an intended screen pass is overthrown and lands beyond the line of scrimmage and linemen are blocking downfield, unless that blocking prevents a defensive player from intercepting the ball.** [§]
 - (vi) Contact on a pick play when the defensive player is already blocking the offensive player, **or if the offensive player's body is not entirely beyond the neutral zone.** [§]
 - (vii) Contact on a "hail mary" pass unless it is clear and conspicuous pass interference.
- (c) Further notes:
 - (i) Non-flagrant contact well away from the play should not be called.
 - (ii) If in doubt as to which player initiated a block, the initiator will be the one who is upright or leaning forward and the player blocked will be knocked back.
 - (iii) Blocking downfield by the offense (against a player in pass coverage) on a forward pass play before the ball is thrown is always offensive pass interference. The defense (particularly the safeties) may see a block and read the play as a run, so drawing coverage away from the destination of the subsequent pass. [×]

10. Late hit:

- (a) The *later* the hit, the less forcible the contact needs to be to warrant a flag. The *earlier* the hit, the more forcible the contact needs to be to warrant a flag. Be more likely to call it the later the hit or the more severe the contact. Slight contact immediately after the ball is dead should not be called. The more badly-behaved either team has been earlier in the game, the more likely you should be to call a foul to maintain game control.
- (b) Any deliberate push against a ball carrier out of bounds is a foul.
- (c) When a ball carrier is near the sideline, contact that occurs before the ball carrier has a foot down out of bounds is a legal hit, **but must be proportionate - i.e. the minimum needed to force the ball carrier out.** [◇]
- (d) When a ball carrier is out of bounds but continues running down the sideline in bounds, any subsequent hit is legal provided they have not eased up and the whistle has not blown. **Once the whistle has blown, any forcible contact is a foul.**
- (e) **When a ball carrier is obviously easing up near the sideline, little defensive force should be necessary to ensure they go out of bounds. Attempts to "punish" the ball carrier should be penalised as unnecessary roughness. Quarterbacks should be given more protection under this than other ball carriers.** [§]

11. Face mask: Remember a face mask foul involves *grasping* the helmet or face mask, not simply *touching* it.

12. Unnecessary roughness:

- (a) An act that occurs well away from the play may be classed as a personal foul even though the act itself is legal. In other words, it is the location of the players with respect to the play that causes the foul, not the legality of the contact.
- (b) Be certain that the act wasn't justified by the play situation (e.g. an interception or fumble return or a broken play). If a player is in position to influence the play or moving towards it, they are a fair target: if they are standing still, they are not.
- (c) It is not a foul if two players are each blocking each other – only contact against a player off their guard needs to be penalised.
- (d) For unnecessary hits away from the ball near the end of a play, make them dead-ball fouls rather than live-ball ones.
- (e) When a player is hit after giving themselves up **or sliding**,[§] a foul is warranted.
- (f) After a touchdown, if there is forcible contact on the ball carrier that is obviously late and intentional, a foul must be called.

13. Roughing the snapper:

- (a) This foul can only occur when it is reasonably obvious that a scrimmage kick will be made: i.e. only on field goal and PAT attempts, or when a team lines up in **an obvious punting formation on 3rd/4th down**.[◊]
- (b) Don't be picky about the one second interval. If the snapper is upright before the one second has elapsed then permit contact, but if they take longer to recover then allow them more protection.
- (c) Don't call a foul if a defensive player contacts the snapper after being blocked by an adjacent offensive lineman.
- (d) Disqualify any player who attempts to punish by contact to the snapper's helmet or spears using the defender's own helmet.

14. Targeting:

- (a) The definition of a defenseless player is per Rule 2-27-14. × If in doubt, a player is defenseless.
- (b) If a hit isn't late, then the ball carrier cannot be defenseless with respect to targeting. A hit that is simultaneous with (or a fraction of a second after) a ball carrier's knee down, is not late.
- (c) Checklist for targeting fouls (adapted from Dean Blandino presentation, 2021):
 - (i) Is the player being hit defenseless (Rule 2-27-14)? If yes, then Rule 9-1-4 is in scope. If no, then only Rule 9-1-3 is in scope.
 - (ii) Is an indicator of targeting present (Rule 2-35)? **Which parts of Rule 2-35-1 apply? If none, there is no targeting.**[‡]
 - (1) What was the body posture of the initiator? If their head stays up then there is less chance of it being an indicator than if they lower it. What body part are they leading with? **Is their trajectory upward (which is an indicator) or do they just run through (which is not)?**
 - (2) Was the initiator attacking with force? An attack involves forward, upward or downward movement. If they are stationary, they are absorbing contact.
 - (iii) Was the contact with the initiator's crown or at the opponent's head/neck area?
 - (iv) Was the contact forcible?

15. Horse collar tackle:

- (a) **The three requirements** to call this are (i) the defender grabs the collar or name plate area; (ii) the ball carrier or simulated ball carrier is pulled towards the ground; **and (iii) the ball carrier or simulated ball carrier is pulled backwards (not sideways or forwards).**[®]
- (b) As with other safety related fouls, if in doubt as to whether it is a foul or not, call it.
- (c) However, just grabbing another part of the jersey and pulling a ball carrier or simulated ball carrier down is not a foul.

16. Chop block:

- (a) It is not a foul if either the high or low player involved simply brushes past or makes only slight contact with the opponent. There must be force enough in each block to change the velocity of the relevant part of the opponent's body.
- (b) By rule it is not a foul if the defensive player initiates the contact.

17. Blind-side block:

- (a) "Forcible contact" requires a build up of momentum. It is less likely to occur if a player is moving slowly. It is more likely to occur the further a player has run at high speed. **Momentum is a combination of mass and velocity. Bigger players don't have to run so fast to build up momentum.**[§]
- (b) When a blocker contacts an opponent with outstretched hands or arms, their elbows and shoulders will inevitably cushion the impact, so making the force less.
- (c) A player who is standing still or moving slowly cannot be "attacking an opponent" and therefore can't be guilty of an illegal blind-side block. **This includes a stationary (or nearly stationary) player who, by not moving out of the way, allows an opponent to run into them. That player is also allowed to brace themselves for the impact without creating a foul for a blind-side block.**[◊]
- (d) An "open field" block generally (i) is outside the tackle box or after the tackle box has disintegrated or after the O-line disperses; (ii) is more than 2 seconds after the snap; and (iii) involves players who typically were more than 5 yards from each other **2**[◊] seconds before the block.

- (e) Be particularly alert when you see a player:[§]
 - (i) approaching an opponent at speed from the side or behind;
 - (ii) going "upstream", i.e. moving in the opposite direction to all other players (e.g. during returns after change of possession);

In each case, imagine they have a brick in their hand.

18. Kick-catch interference:

- (a) Anything that impedes the receiver from the opportunity to catch the ball should be called a foul. Their balance will have been disturbed, so hindering their ability to catch the ball cleanly. When in doubt, it is a foul. This includes:
 - (i) contact with the receiver (however incidental);
 - (ii) running menacingly close to the receiver and within their area of focus/vision;[◊]
 - (iii) standing too close to the receiver;
 - (iv) yelling or making other intentional noise while close to the receiver;
 - (v) waving arms in front of the receiver;
 - (vi) forcing the receiver to step around the opponent or change path in an effort to catch the ball.
- (b) It is not a foul where:
 - (i) the Team A player runs past the receiver without touching them or making them change course;
 - (ii) the receiver "gives up" their attempt to catch the kick too easily;
 - (iii) the receiver catches the ball and there was no contact and the extent of any non-contact interference is slight or in doubt: don't award cheap 15-yard penalties.
- (c) A player who viciously contacts a potential kick receiver has committed a flagrant personal foul and should be disqualified. Give only the personal foul signal (not the signal for kick-catch interference) in this case.
- (d) A player who is in the process of catching a kick must be given an unimpeded opportunity to complete the catch before being contacted. This protection terminates if the player muffs the ball, unless they have given a valid fair catch signal and still have an opportunity to complete the catch (Rule 6-5-1-b).

19. **Summary:** When considering personal fouls, ask whether the potential offender had options. Could they have chosen to do something differently with respect to the contact? Penalise players who choose the bad option.

3.4 - Non-contact fouls

1. Delay of game:

- (a) If Team A is still in the huddle, or moving into formation, with 10 seconds to go, warn them verbally that there are 10 seconds remaining. Always throw the flag when the count reaches zero, unless the snap is very imminent (i.e. the quarterback is calling out "huts"), in which case they can have an extra second.
- (b) If there is a visible play clock, when it reaches zero, look and see if the ball has been snapped. If it has not, throw a flag.
- (c) After a score, it is a delay of game if either team is not on the field (or on the field but still in the huddle) within one minute regardless of whether the ready for play has been given or not. For a first offence, warn the head coach of the team rather than throw a flag. (Warn for first offence and penalise second and subsequent.)[◊]
- (d) If no (or few)[◊] players from Team B are ready to play anytime when Team A is set to snap the ball, penalise Team B for delay of game. Do *not* give Team A a free play. Near the end of a timeout (usually 15 seconds before the end), the officials on the sideline are responsible for ensuring that the captain or coach of the team knows that the timeout is about to end.
- (e) If Team A makes last second substitutions (rushing to the line of scrimmage while in the process of substituting), Team B must be given an opportunity to "match-up". If the play clock expires prior to the snap, the officials must determine whether Team B was given ample opportunity to react to the "rushed" substitution. If Team B reacts promptly but the play clock expires, Team A will be assessed a delay of game foul. If any Team B players do not leave and enter the field of play quickly, or do not start the process within 3 seconds of Team A's last substitute entering the field of play, (i) Team A shall be allowed to snap the ball and (ii) if Team B has more than 11 players on the field of play, it will be penalised for illegal substitution.[®] (Rule 3-5-2-e.)
- (f) If Team A snaps the ball in a situation where they have been asked not to (e.g. while Team B are being allowed to make matching substitutions), for a first unintentional offence shut down the play and issue a warning. (Warn for first offence and penalise second and subsequent.)[®] (Rule 3-5-2-e)

2. **Players not within the nine-yard marks:** Don't call this if Team B reacts to the offending player, e.g. by a Team B player lining up opposite them.

3. Illegal formation and eligibility of receivers:[§]

- (a) Don't wait until the fourth quarter to enforce these rules - deal with illegal formations as soon as they first arise.
- (b) It is always a foul when Team A has five (or more) players in the backfield at the snap. Team A gains a blocking advantage by being further away from the defense.
- (c) It is still a foul for five players in the backfield even if Team A has only 10 (or fewer) players on the field at the snap.

- (d) Work to keep offensive linemen legal. Only call an intended offensive lineman as being in the backfield if:
 - (i) it is obvious (clear gap between their head/shoulders and the nearest Team A lineman), or
 - (ii) they are lined up with their head clearly behind the rear end of the snapper - a foul to be called without warning, or
 - (iii) when a warning to the player and a subsequent warning to the coach are ignored. (Warn for first and second offence and penalise third and subsequent.) §
 - (e) Give more leeway to wide receivers and slot backs in determining whether they are on or off the line of scrimmage than you do to interior linemen or tight ends. Be particularly generous on fields that are not well marked out.
 - (f) Only regard a wide receiver as covering an inside receiver on the line of scrimmage if there is no stagger between their alignments. If in doubt, the inside receiver is *not* covered up.
 - (g) In determining the number of players in the backfield, be generous to players who may not precisely meet the requirements of Rule 2-27-4. If a Team A player is borderline, regard him as a back if there are fewer than 4 backs; regard him as a lineman if there are fewer than 7 linemen. If there are multiple borderline players, do the above for each.
 - (h) Remember that if Team B sees a player with an eligible number lined up near the line of scrimmage, they will assume they are also eligible by position. Similarly, if Team B sees a player with an ineligible number lined up near the line of scrimmage, they will assume they are on the line of scrimmage.
 - (i) On a trick or unusual play, formations should have the highest degree of scrutiny and should be penalised unless they are *completely*^o legal.
4. **Snapper moving the ball:**[§]
- (a) When taking their stance, permit the snapper to move the ball forward no more than a ball length, and never across the line to gain or goal line. If they move it forward more, shut down the play, reset the ball and warn the player and their coach that further infractions will be penalised. (Warn for first offence and penalise second and subsequent.)
 - (b) When taking their stance, if the snapper lifts the ball off the ground, shut down the play, reset the ball and warn the player and their coach that further infractions will be penalised. (Warn for first offence and penalise second and subsequent.)
 - (c) If the snapper simply rotates the ball in place (e.g. to improve their grip), this is not a problem.
5. **False start:**^λ
- (a) Movement by a Team A player^λ is not a false start unless it:
 - (i) is movement of one or both feet; or^λ
 - (ii) is sudden; or
 - (iii) causes a defensive player to move in immediate reaction and this is the first time such movement has been observed; or
 - (iv) is a restricted lineman lifting their hand(s). §
 - (b) If a^x back misses the snap count, makes a sudden movement and then stops abruptly, it is a false start. (If they were genuinely going into motion, they wouldn't stop.)
 - (c) Team B's "immediate reaction" needs to be a typical play response. Merely pointing at Team A players who may have moved is NOT. §
 - (d) Don't be picky: if in doubt as to whether movement was prior to the snap or not, it was *not*.
 - (e) When in doubt, a quick or abrupt movement by the snapper or quarterback *is* a false start. §
6. **Offside:**
- (a) When a defensive player, before the snap, moves and an offensive player subsequently moves, a conference between the Umpire and the wing officials is mandatory. This is to determine if the defensive player was in the neutral zone and if the offensive player was threatened. **When in doubt, the defensive player was in the neutral zone.** § When in doubt,^λ the offensive player *is* threatened. If the Team A player who first moves is not threatened, it is a false start.
 - (b) When a defensive player, before the snap, crosses the neutral zone and charges towards a Team A back, it is a dead-ball offside foul. The time to call this as a foul is when the defender passes the hip of the nearest Team A lineman.
 - (c) **When in doubt whether a defensive player who has crossed the neutral zone contacted a Team A player, there was contact.** §
 - (d) Don't rule a defensive player offside if they are stationary and only intruding on the neutral zone by a trivial amount.
 - (e) Don't be picky about offside, particularly on fields that are not marked perfectly.
 - (f) Don't call offside if the defensive player is moving forward at the snap but is not actually in the neutral zone.
7. **Team B movement and signals:**
- (a) A "stem" is where a Team B lineman moves laterally, and the movement is at least enough to change from head-up on one opponent to head-up on another, or from head-up to gap between two opponents, or vice-versa.
 - (b) When there is a coordinated movement by two or more Team B linemen, the signal to initiate it must not come from a lineman.

- (c) A movement by a Team B lineman that constitutes a stem is legal. A quick, abrupt or exaggerated movement by a Team B lineman that is not a stem (e.g. stamping a foot, waving an arm) should be interpreted as an attempt to get Team A to false start.
- (d) The following are fouls by Team B:[®]
- Replicating a Team A starting signal (e.g. words or a clap), whether or not Team A reacts. Other than a clap, it is not a foul to make a noise that Team A isn't using, or to make hand gestures that don't create a clapping sound.
 - A quick, abrupt or exaggerated movement by a defensive lineman that is not a stem *and* causes Team A to false start.
- (e) Penalise a Team A player for delay of game if they use words that sound like "move" or "stem" (Rule 7-1-5-a-5).
- (f) With the exception of disconcerting signals, infractions under Rule 7-1-5 only become a foul if Team A reacts and does so authentically. If legal movement by a Team B lineman causes a Team A player to reach into the neutral zone and touch the Team B player, it is an encroachment foul on Team A. That is not an authentic reaction to being threatened.
8. **Illegal motion:** A player is in illegal motion only if their forward movement is conspicuous. A motion man angling forward while in motion at the snap has committed a live-ball foul, not a false start.
9. **Ineligible receiver downfield:**
- Call it only if it is conspicuous.
 - An ineligible receiver must be clearly more than 3 yards down field at the time the pass is thrown - don't be picky if the player is just at 3 yards. Be cautious that if a player is seen 5 yards downfield and moving downfield as the ball passes them, they were probably not more than 3 yards downfield when the ball was thrown.
 - If a lineman blocks downfield, call it as ineligible downfield unless they go far enough to block a **defensive player**[‡] in pass coverage in which case call it as offensive pass interference.
 - By rule, it is not a foul for ineligible receiver downfield if the pass is legally thrown away near or beyond the sideline.[®]
 - See 3.4.3.f above for determining whether a Team A player is eligible or not.[‡]
 - Don't call it if the offense is legally throwing the ball beyond the neutral zone to save a loss of yardage.
 - Don't call it if a screen pass is overthrown and lands beyond the neutral zone, unless the presence of the ineligible receiver prevents a defensive player from catching the ball.
10. **Intentional grounding:**
- Don't call it if the passer was contacted clearly *after* they have started the act of throwing the ball, or if the ball was touched. Under these circumstances, you must assume the passer intended to throw the ball to a receiver.
 - Do call it if the passer was contacted *before* they have started their throwing motion. They are not allowed to throw the ball away to avoid a sack. In some circumstances it may be appropriate to rule the ball dead (rather than penalise for intentional grounding) because they were held and their forward progress stopped.
 - Do not call intentional grounding if the passer throws the ball away **when not under defensive pressure**. They are entitled to waste a down if they are in no danger of being sacked. The clock is not a factor. (**Exception:** if the passer throws the ball only a few yards - typically less than 5 yards from them.)[°]
 - There is no need to call **intentional grounding**[°] if the pass is intercepted *and* this would be the only foul called.
 - Getting the ball to within one yard of the neutral zone is to be regarded as close enough. Don't be technical on this.
 - When in doubt whether the forward passer is or has been outside the tackle box, they are or have been outside the tackle box.**[§]
 - If a pass is touched by an ineligible receiver, it will normally just be a foul for illegal touching. However, if the passer does this in an obviously deliberate manner to avoid a loss of yardage, then a foul for intentional grounding is justified. By rule, you cannot have illegal touching on an illegal pass.
11. **Illegal substitution:**
- If a replaced player is leaving the field of play or end zone but is still clearly on the field of play at the snap, then it should be called as a foul.
 - A replaced player who re-enters the field after leaving it has fouled. However, a player who leaves the field believing they are being replaced, but who is not in fact replaced, should be allowed to re-enter without penalty (provided this is not a deception).
 - If substitutes enter the field thinking the ball is dead but don't interfere with play, then don't call it.
 - If the offense breaks its huddle with **too many**[‡] players on the field, this confuses the opposition and should be penalised. However, there can be a foul only if the ball has been declared ready for play (Rule 2-14) or the 12th man does not leave the huddle immediately.
 - If the defense has **too many**[‡] players on the field when the snap is imminent,[×] there is no foul until the ball is snapped, **unless Rule 3-5-3-c applies.**[®]
 - Fouls associated with the substitution process and having **too many**[‡] players on the field will normally be violations of Rule 3-5. However, an intentional attempt to confuse opponents will be penalised for unfair tactics (Rule 9-2-2-b).

12. Failure to wear mandatory equipment:

- (a) Regard failure to have a mouthpiece or to secure all points of a chinstrap as seriously as failure to wear a helmet. If you observe a player leaving the huddle without a mouthpiece or chinstraps, remind them to secure their equipment. Players who ignore the reminder must be dealt with by rule (Rule 1-4-8), but give quarterbacks and other players calling signals more time to do so. The same procedure applies to players wearing opaque or mirrored eye shields.
- (b) Do not stop either the game clock or play clock **unless you are charging a team with a timeout due to a player not responding to 2 notifications to leave the field.** [®] If a player does respond and leave the field, Team A needs to ensure it snaps the ball before the play clock expires and Team B needs to ensure it has no more than 11 players on the field at and after the snap. [®] If a restricted lineman needs to be replaced, it will be a false start when they stand up, **unless Team A takes a timeout.** [◊]
- (c) For other non-critical mandatory equipment, instruct the player to remedy the problem the next time they are off the field. If they ignore the instruction, when they return to the field tell them to go off and fix the problem immediately. If they do so, then fine. If their team replaces them immediately, do not penalise for an illegal substitution. If their team takes a timeout or suffers a delay of game penalty, that is their choice. If they stay and attempt to participate in a play, deal with them by rule (Rule 1-4-8).

13. Illegal equipment: Anything that might be a risk to participant safety must be dealt with before the ball is next put in play. Other infringements may be left for the player to rectify next time they leave the field, but must be rectified before they can legally return.

14. Illegally kicking the ball: If a player intentionally contacts the ball with knee, lower leg or foot with the objective of propelling the ball in any direction, they are kicking it. If it touches their knee, lower leg or foot incidentally or as part of an attempt to obtain possession of the ball, this is not regarded as a kick and there is no foul.

15. Illegal wedge: For a wedge to be illegal (Rule 6-1-10), it has to form before the end of the kick and continue during the beginning of the return. If they touch/hold hands, this is a dead giveaway. It is *not* an illegal wedge if they are moving towards their own end line. Once the return gets upfield, players will come together as a consequence of the play – this is *not* considered as an illegal wedge.

16. Offside on free kick:

- (a) Officiate the Team A restraining line as a plane (**at the edge of the line nearest Team A's goal line, if you have replay.**) [§]
- (b) On an onside or other short kickoff (**intentional**^² or unintentional), any player (other than the kicker or holder) breaking the plane before the ball is kicked is offside.
- (c) On a deep kickoff, do not be too technical.
- (d) Only call a foul if a kicking team player (other than the kicker) obviously takes a run up of more than 5 yards on a free kick. Players who simply adjust their position or stance should not be penalised for being temporarily more than 5 yards behind. The aim of the rule is to reduce a player's momentum at kickoff.

17. Handing the ball forward illegally: Handing the ball forward (except where allowed by rule) is always a foul. A team can gain significant yardage (as well as the benefits of deception) from this illegal play.

18. Team A player out of bounds:

- (a) Whenever any Team A player returns inbounds after voluntarily going out of bounds during a kick play, or an eligible receiver touches the ball illegally after voluntarily going out of bounds during a pass play, it is always a foul. A Team A player leaving the field of play gains an advantage by avoiding being blocked. Remember that a player is out of bounds even if only one foot touches the sideline or end line – this **should not be ignored.**
- (b) Any contact by a Team B player that causes a Team A player to go out of bounds should be regarded as the cause of it, provided the Team A player attempts to come back in bounds immediately.

19. Continued participation without helmet: "The immediate action in which they are engaged" ends once a player disengages from contact with an opponent and is no longer confronting, or being confronted by, that opponent. A player who loses their helmet while engaged with an opponent (including when overpowering an opponent) is expected to disengage when it is safe to do so. A player whose helmet comes off without being engaged or confronted by an opponent (i.e. they are just running) cannot continue to participate from that point. [§]

3.5 - Unsportsmanlike conduct and fighting

1. Celebration:

- (a) Celebration is different from taunting – be more tolerant of it. **Allow brief, spontaneous, emotional reactions at the end of a play. Penalise prolonged, self-congratulatory or demeaning acts.** [§]
- (b) A "sack dance" over a tackled opponent should always be penalised.
- (c) **Always penalise spiking the ball after a play, except for a spontaneous celebration after a score (or where the player reasonably believes they have scored).** However if this is in the direction of an opponent (even unintentionally), it is taunting and should be penalised. For the ball to be "spiked", it must be forcibly thrown into the ground - merely dropping it isn't a foul.
- (d) A celebration should be penalised if it involves:
 - (i) any of the 20+ specific prohibitions in Rule 9-2-1;
 - (ii) the ball;[×]

- (iii) player equipment;
- (iv) field equipment (including a goal);
- (v) any object taken from another person;
- (vi) any prop;
- (vii) a player going to the ground in a delayed (not immediately after the score) and unnecessary manner.

- (e) An act that isn't on the above list is probably legal, so be tolerant of it, unless you believe it is abusive, threatening or obscene, provokes ill will, or demeans the game. Don't be a prude (one who is excessively concerned with being or appearing to be proper, modest, or righteous; or a person who is easily shocked or offended by things that do not shock or offend other people).
- (f) If an illegal celebration occurs near the goal line, assume that it occurred *after* the score unless an official was in an excellent position to rule on its exact location.
- (g) "Choreographed" means that one or more players have clearly pre-decided, pre-arranged or rehearsed how they will move (as in a dance).

2. Dissent:

- (a) Players play with passion and emotion – coaches share the same traits. At various times, players and coaches can be happy or sad, joyous or disappointed, satisfied or frustrated. These are normal human emotions (officials have them as well), but need self-control.
- (b) Players and coaches are entitled to be disappointed. It is only when it is excessive or challenges an official's authority that it becomes dissent.
- (c) Dissent is when players, coaches or other persons subject to the rules:
 - (i) speak in an abusive, aggressive or denigrating manner to an official;
 - (ii) assert as true something that it is contrary to rule or an official's ruling, or assert as false something that is true;
 - (iii) continue to argue a proposition after being informed that it is incorrect, or asked to stop;
 - (iv) make denigrating comments about an official or a decision while speaking to each other;
 - (v) make gestures (with hands or otherwise) that signify frustration or lack of respect at an official;
 - (vi) throw/kick the ball or equipment in disgust;
 - (vii) move aggressively towards an official to argue or complain.

Dissent differs from a player or coach asking a genuine question.

- (d) If a player or coach shows the official respect, then the official will show them the same level of respect in return.
- (e) We distinguish between overt dissent and covert dissent. The former is conspicuous, usually because the speech is loud enough for many people to hear, or the gestures are clear and in the open. Covert dissent is where only the official hears it and can be treated slightly differently.
- (f) There are six levels of response to dissent:
 - (i) **Ignore it.** If the dissent is minor, and is the first example of its kind from that player or team, then it *can* be ignored. It might be an isolated incident, never to happen again. However, there is always a risk that ignoring dissent will give encouragement to the participants to repeat it. Ignoring it is certainly not the appropriate response to repeated dissent.
 - (ii) **Pretend you didn't hear it.** Ask the player or coach to repeat their comment ("what did you say?"). If it was inappropriate, they will likely not repeat it. If they do, then there is no doubt that you must respond firmly, professionally and rapidly.
 - (iii) **Quiet word.** A quiet word with a player or coach is often more beneficial than an immediate penalty. It shows your commitment to resolving the issue without recourse to a strict application of the rules of the game.
 - (iv) **Public rebuke.** Sometimes, the player or coach needs to be spoken to loudly enough that their teammates are aware. This may be necessary in order to solicit their help in controlling their emotions.
 - (v) **Penalty.** If dissent is conspicuous to spectators, then it needs to be penalised as unsportsmanlike conduct. Conspicuous dissent includes all actions that involve audible abusive language, thrown equipment, or running towards an official. Verbal dissent also certainly needs to be penalised if it is said a third time (or more).
 - (vi) **Disqualification.** If a player or coach is penalised for dissent twice, then they will be disqualified under Rule 9-2-1. In extreme cases, an act of dissent may be so flagrant as to require immediate disqualification.

There is no need to go through these levels in order. A serious (and conspicuous) act of dissent may require immediate penalty, and possibly even disqualification.

- (g) The following acts by a participant should *always* result in a foul being called:
 - (i) making an aggressive gesture towards an official;
 - (ii) speaking in an abusive, aggressive or denigrating manner to an official that can be heard clearly by spectators;
 - (iii) making "demonstrative disagreement", such as raising hands in incredulity;
 - (iv) smacking themselves to demonstrate how they were fouled;
 - (v) running directly at an official to complain about a call;
 - (vi) making excessive enquiries about a call, even in a civilised tone (as in 3.5.2.f.v above).

- (h) Failing to deal with dissent is letting your colleagues and the sport down. Not only does dissent undermine officials, it can also severely disrupt the atmosphere and flow of a game. If you think you are unconcerned by dissent and ignore it, remember that the same player may make the same comment to a less imperturbable official next week, but that may be the straw that breaks the camel's back and causes that official to quit.
- (i) If you hear dissent directed at another official, *you* deal with it. An important part of officiating teamwork is to back up your colleagues in this way.
- (j) Engage with the captain(s) and coach(es) to make clear it is their responsibility to control their players, to prevent dissent or to stamp it out at first sign. Doing this shows that the official is attempting to work *with* the teams rather than penalise.
- (k) Where appropriate, advise coaches and players to ask genuine questions rather than make assertions about what is true or false.
- (l) If left unchecked, dissent is like a disease that will grow and undermine your authority.
3. **Flagrant unsportsmanlike acts requiring disqualification:** The following acts of unsportsmanlike conduct normally are flagrant and require disqualification:
- (a) Spitting at an opponent or official.
- (b) Any abusive language that involves derogatory reference to an opponent's or official's ethnic origin, colour, race, nationality (except in the context of international competition), religion/belief, sex/gender identity, age, class or social background, political belief, sexual orientation, disability or any other speech intended to demean or brutalize.
- (c) **Participating without being cleared by a healthcare professional after suspicion of a concussion.**
- (d) Any other act of unsportsmanlike conduct which, by its nature or prolonged duration, is extremely objectionable, conspicuous, unnecessary, avoidable or gratuitous.
- (e) Any action specifically directed at one or more officials, officials assistants or spectators is generally more extreme than the same action directed at an opponent.
4. **Multiple fouls:**
- (a) Do not penalise a player or team twice for the same unsportsmanlike act.
- (b) However, where there are multiple, distinct acts by the same player or by different players, it is appropriate to penalise them separately. Two unsportsmanlike acts by the same player will result in them disqualifying themselves.
- (c) Examples of separate acts include:
- (i) a prohibited celebration followed by dissent at an official's call;
- (ii) taunting an opponent followed by bowing to spectators;
- (iii) shoving after the ball is dead followed by removing a helmet;
- (iv) a prohibited celebration followed by one or more substitutes entering the field to join the celebration;
- (v) **anyone** reacting in an unsportsmanlike manner following being informed of the circumstances of a prior foul;
- (vi) **walking away after an unsportsmanlike act, but then returning to commit another unsportsmanlike act.** §
- (d) Examples of acts that normally would NOT be regarded as separate include:
- (i) more than one player participating in a delayed, excessive, prolonged or choreographed celebration;
- (ii) a player taunting more than one opponent;
- (iii) a player bowing in more than one direction;
- (iv) a player making one unsportsmanlike comment or gesture and then **a similar** one a few seconds later.
5. **Other points regarding unsportsmanlike conduct:**
- (a) **Live or dead:** If in doubt whether an unsportsmanlike conduct foul occurred while the ball was live or dead, it was dead.
- (b) **Who to penalise:** Do not penalise the conduct of anyone other than a player or coach. If someone else is giving you a problem, ask the team or game management to deal with it.
- (c) **Simulating being roughed:** Normally a kicker who simulates being roughed should be ignored. A penalty should only be administered if necessary to exert proper game control.
- (d) **Simulating other fouls:** **A player attempting to draw a foul by an opponent by conspicuously simulating a reaction to mild or non-existent physical contact has committed unsportsmanlike conduct.** §
- (e) **Removing helmets on the field:** Players who unthinkingly remove their helmets on the field of play should not be penalised unless they are (i) directing anger or criticism at an opponent or an official; or (ii) celebrating. Remind them to keep their helmets on. A player removing their helmet in the vicinity of the sideline just prior to entering the team area should be ignored.
- (f) **If you observe a coach signalling to an obviously uninjured player to go down, this is one unsportsmanlike conduct foul for feigning an injury, but both the player and the coach will have the foul counted against them for the purposes of Rule 9-2-6-a.** §
- (g) **Unusual technical fouls:** When a participant inadvertently breaches an unusual rule (e.g. Rule 1-4-10), a first offence can usually be dealt with by a warning and an immediate requirement to rectify the breach. A penalty is only necessary when the breach has been intentional. **(Warn for first offence and penalise second and subsequent.)**

6. **Sideline interference:**

- (a) While the ball is dead:
 - (i) Provided participants in the team area respond reasonably promptly to requests to get back from the sideline, there is no need to warn or penalise them, no matter how many times it happens.
 - (ii) Give a sideline interference foul (Rule 9-2-5) only if a head coach repeatedly (i.e. more than once) ignores requests (made while the ball is dead) to keep their team back from the sideline while the ball is alive or in continuing action after it is dead.
- (b) While the ball is in play:
 - (i) Coaches, substitutes and other non-players *on* the field should always be flagged for sideline interference (Rule 9-2-5). An exception is not to be too bothered if the ball is near Team B's goal line and the personnel are still near their team area.
 - (ii) If they are *between* the sideline and the coaching box line, use your discretion and issue a verbal warning if they did not actually cause any problem.
 - (iii) Any contact between an official and a team member on the field or between the sideline and the coaching box line should be called as a team unsportsmanlike act (Rule 9-2-5-b) (with normally a 15-yard penalty from the succeeding spot) even for a first offence. This also applies if there is no physical contact but the official is forced to change direction either to avoid contact or to maintain their view of what they are observing.

7. **Fighting:**

- (a) Three rules talk about "striking" an opponent: how do you decide which to call?
 - (i) Personal foul (Rule 9-1-2-a): Normally use this for action that occurs while the ball is live. Unless the action could cause catastrophic injury, don't regard it as flagrant.
 - (ii) Unsportsmanlike conduct (Rule 9-2-1-a-1-j): Normally use this for action that occurs in the aftermath of a play.
 - (iii) Fighting (Rules 2-32-1 and 9-5-1): Normally reserve this for more serious, more severe, more prolonged action. It is unlikely that a single strike constitutes a fight.
- (b) If action is deemed to be "fighting" then the player must be disqualified. It is *not* fighting if players are merely pushing each other (i.e. no deliberate punches, kicks or blows are struck or aimed). If in doubt, it is *not* fighting.
- (c) Disqualify a player for punching only when the act appears to be malicious. Consider factors such as the level of intent, the force of the blow, the duration of the incident and whether it is a first offence. Minor, frustration-driven contact may be treated as an unsportsmanlike act, unless one or more of these factors applies. [®]
 - (i) We have seen players disqualified for fighting because an official saw them "throw a punch". When evaluating the video of those incidents, it is almost always the case that what the official interprets as a punch is a failed attempt by a tackler to grasp an opponent or force a fumble - movements are rapid and jerky but don't always lock onto their target.
 - (ii) Why would a player throw a punch during live ball action? A punch is not going to land a blow on the opponent's head because of their helmet. It is not likely to land a blow on the opponent's upper torso because of their pads. It might land a blow if it was precisely into the solar plexus, but that is also near where ball carriers carry the ball and therefore a legitimate target for forcing a fumble.
 - (iii) If you clearly saw a defensive lineman (for instance) thrust their closed fist(s) into an offensive lineman's stomach area, you might regard that as a personal foul, but only if you clearly saw closed fists - open or partially-open hands would be an indicator that this was not intended as foul play.
 - (iv) Striking an opponent is most likely to be done out of frustration at being held or taunted. This is usually best dealt with as unsportsmanlike conduct, unless it is prolonged (i.e. there are several blows) at which point it becomes a fight.
 - (v) However, where a punch is not an immediate act of frustration, it may justify disqualification. This is more likely when the action has at least one of the following characteristics: delayed, calculated, very forceful, contemptuous, repeated.
 - (vi) If in doubt as to whether a player has intentionally elbowed an opponent, look at the player's hand. It is a natural reaction to make a fist before striking with the elbow. An open hand probably indicates unintentional contact.
 - (vii) Similarly, punches based on frustration tend to have a "wind up" where the puncher pulls their arm/elbow back before striking. Short-arm jabs are possible, but less likely to inflict a major blow.
- (d) During a fight, try to distinguish between those players (on the field at the start of the fight), substitutes and coaches who actively participate in a fight and those who are trying only to separate the combatants. The latter should not be disqualified.
- (e) Only disqualify a player if you are certain of their number. If two opposing players are fighting with each other, don't disqualify one unless you know the identity of the other.
- (f) Unnecessary roughness when Team B has no chance to win and Team A has clearly indicated its intention to "take a knee" should normally result in disqualification of the player committing the foul.

8. **Retaliation:**

- (a) For the purposes of this section, we define retaliation as when a player commits an aggressive act in direct response to an aggressive act by an opponent on themselves or a teammate. Retaliation may be by physical contact or by unsportsmanlike word or deed. Retaliation normally occurs within a few seconds of the original act, but could in theory be delayed.

- (b) Normally, we want to impose the most severe punishment on the participant who started the incident (the "instigator"). The "punishment" in this context, may be a warning (for a minor infringement), a penalty (for a significant infringement) or disqualification (for a serious infringement).
 - (c) If the retaliation is of less seriousness than the original act, the retaliator should normally receive a lesser punishment than the instigator. For example, if A31 commits an unnecessary roughness foul on B45, and B45 retaliates by (a) pushing A31 away; or (b) swearing at A31, then in both cases we would likely not penalise B45, but simply warn them. This would also apply if A31 spat on B45 (a mandatory disqualification according to 3.5.3) and B45 retaliated by pushing A31. A31 would be disqualified, but B45 may only be penalised or warned.
 - (d) However, if the retaliation prolongs or escalates the incident by being as (or more) severe than the original act, then normally the retaliator should receive the same or a higher punishment than the instigator. For example, if B45 responds by (a) committing an equally unnecessary act of roughness on A31; or (b) starting a fight with A31, then both would be severely penalised. In the case of a fight, Rules 2-32-1 and 9-5-1 together mandate disqualification of both players.
 - (e) In any case where retaliation is delayed (to the next play or later) and deliberate, disqualification of the retaliator alone is normally required. This includes cases where the retaliator is a teammate of the player who was the victim of the original attack.
9. **Pre-game:** During the pre-game warmups and during the coin toss ceremony, penalise acts by anyone subject to the rules that are designed to provoke their opponents.
- (a) This includes conspicuous acts such as choreographed action (e.g. a haka), flag planting, waving a team's flag at an opponent or its supporters, or any similar action (or simulation of these).
 - (b) Taunting an opponent and other non-conspicuous acts should also be penalised.
 - (c) If you can see signs of the build up to one of these provocations, step in and try to persuade the player(s) to stop. Penalise if they do not do so.
10. Apply a zero tolerance policy to acts of unsportsmanlike conduct and fighting in junior/youth football.
11. Approved Ruling 9-2-6:II defines which fouls count towards disqualification under Rule 9-2-6-a.

3.6 - Fouls that always involve advantage

The fouls that previously appeared in this section have been moved to Section 3.3 (Contact fouls) or Section 3.4 (Non-contact fouls) as appropriate. ×

3.7 - Catches and fumbles

1. If the ball moves from the control of one player to another (whether teammate or opponent) during the act of gaining possession, the ball belongs to the player in final control (provided they had control inbounds). This is not a simultaneous possession. If the last player in control did not have control inbounds, or any player was out of bounds at the same time as they touched the ball, the ball is loose out of bounds. If in doubt as to whether a player had control inbounds, they did not.
2. If the receiver gets their toe inbounds but their heel or ankle^o comes down a fraction later out of bounds (or vice versa) then the pass is incomplete. If the whole foot touches the ground, it all has to be inbounds for the catch to be completed. Similarly, the fingers, palm and wrist are all regarded as part of the hand.^s This principle does not extend to the foot and leg/knee, nor to the hand and arm/elbow – these are regarded as separate parts of the body and only the first contact with the ground is relevant.
3. It is not a fumble if the ball is stripped after the ball carrier has been driven back. The ball is dead once the ball carrier is so held that their forward progress is stopped.
4. A player has the ball long enough to become a ball carrier when, after their foot is on the ground, they do one of the following (sometimes known as "acts common to the game") (Rule 2-4-3):
 - (a) avoiding or warding off impending contact by an opponent;
 - (b) tucking the ball away;
 - (c) advancing the ball (or retreating with it); or extending it towards the goal line or line to gain;
 - (d) taking additional steps while upright (i.e. not while falling to the ground);
 - (e) passing the ball or handing it off.
5. Do not try to be too technical on ruling a catch. We do not want officials who try to have "the greatest eyes in the history of the game" and rule too many times the receiver has completed the process of the catch and fumbled the ball when it should be an incomplete pass. The most important principle is "when in doubt, incomplete".
6. We use exactly the same approach whether the catch is in the end zone or in the field of play.
7. In ruling whether a Team A player has passed or fumbled the ball, bear in mind the following:
 - (a) Any action by the player's hand moving forward and the ball coming out should be ruled a forward pass.
 - (b) If the player is able to see the defender approaching, they are likely to be able to move their hand or arm forward before they are contacted. When they do not see the hit coming, the chances are greater that a fumble occurred.
 - (c) After the player was hit, if the ball lands behind them it is more likely that a fumble occurred.
8. Checklist for possession (adapted from Dean Blandino presentation, 2021):
 - (a) Is control established with hand(s) or arm(s)? Was control established before the ball touches the ground (catch only)? Slight movement is not a loss of control but a bobble, juggle, bounce or the hands coming off the ball would be.

- (b) Establish which body part touched the ground (or pylon) first. Was it completely in bounds?
- (c) How long did the player have control of the ball?
 - (i) If upright, when did they transition from receiver to ball carrier? Did they have the ability to ward off or avoid an opponent? Did they tuck the ball away, turn upfield and/or take additional steps? Did they extend the ball for additional yardage (goal line or line to gain)?
 - (ii) If going to ground, did they maintain control when they touched the ground? Or, did they perform an act common to the game (e.g. extending for additional yardage) on their way to the ground?

3.8 - Other rules applications

1. Fair catch signals:

- (a) Don't be picky about fair catch signals. Any waving signal or raising a single arm above the head is sufficient to indicate that a fair catch has been called for.
- (b) Players obviously shading their eyes from the sun have *not* signalled for a fair catch.
- (c) Any "get away" or "T"[®] signal before or after the ball touches the ground is an invalid fair catch[°] signal. A "T" signal is when a player stretches their arms out, similar to an official's matching substitutes signal [Sup36].
- (d) A receiver who points at the ball and keeps their hands below their shoulders with no waving motion has made no signal and can advance the ball. A receiver who keeps their hands below their shoulders and has a waving motion, or one who has their hands just above the shoulders with no waving motion, has made an invalid signal.

2. Poor field markings:

- (a) **Onside kick:** If in doubt on a poorly marked field, the chain can be used following a free kick to measure whether a spot of first touching is illegal or not.
- (b) **Incorrect hash marks:** Sometimes a field is marked with hash marks at the wrong distance from the sideline (e.g. the NFL distance of 70ft 9in instead of the correct 60ft). If this is the case, to ensure the integrity of the game, do not play to the marked hash marks - use cones or other indicators behind the end lines to approximate the line of the hash marks, and spot the ball between them. §

3. Spotting the ball:

- (a) **Spotting the ball for a new series:** The ball should be placed nose-on to a yard line after a change of possession. For example, if a return ends with the ball between the B-28 and B-29, move the ball to the B-29. The exception is the ball should not be moved if, inside Team B's three-yard line, a kick is downed on the ground or a fourth-down run/pass play ends. §
- (b) **Change of possession close to goal line:** If an interception, kick catch or recovery is made inside the one-yard line and immediately carried into the end zone, try to make the play a touchback rather than a momentum exception. Where Team A illegally touches a kick near the goal line, try to rule the touching as being in the end zone, particularly if they carry the ball into the end zone.
- (c) **Ball coming out of end zone:** If there is a change of possession in the end zone (or the momentum exception rule applies), when in doubt during the return the ball has NOT left the end zone.
- (d) **Ready for play:** The ball can never be ready for play if an official has not at least touched it at the succeeding spot. If a player spots the ball themselves, and they get the ball in the correct position, an official still needs to touch it and get into position to officiate before the ball becomes ready for play (Rules 2-2-4 and 4-1-4).[®]

4. Timing:

- (a) **Timing in the last few seconds of a period:**
 - (i) One second can be enough to make the ball live. If the clock starts on the ready, the Referee should wait until Team A is set before declaring the ball ready.
 - (ii) Two seconds are not long enough for the ball to become live and then dead again before time expires[°] (Rule 3-2-5).
 - (iii) With five seconds or less remaining when the ball is snapped, a normal field goal attempt will end the period.
- (b) **Timing on free kicks:** No time will run off the clock if a free kick is recovered cleanly by a player who is on the ground or has signalled for a fair catch. At least one second will run off if they muff the ball and then catch or recover it.
- (c) **Timeouts and flags:** When in doubt, a charged team timeout preceded (and may thus cancel) a 5-yard penalty foul that prevented the snap. §
- (d) **Timeouts and injuries:** If a team calls a timeout, but before the Referee makes the announcement, the other team is discovered to have an injured player, give the first team their timeout back. If one team calls a timeout right after the end of the play and at the same time an injured player is discovered, give them the timeout back unless they choose to still take it. Remember that a timeout cannot be used to allow an *injured* player to stay in the game, though it can be used for a player whose helmet has come off (Rules 3-3-6-a-1 and 3-3-10-a). §
- (e) **Coach requesting a timeout:** Officials should not be distracted from their game duties by the possibility that a head coach may request a timeout.
 - (i) When a snap or free kick is imminent (i.e. when Team A is in its formation), wing officials must not turn their eyes away from the field of play. In these circumstances, the head coach may need to attract the attention of one of the officials in the middle of the field (referee, umpire, back judge), or

even the wing official on the opposite sideline, who is facing them. A "T" hand signal (like signal Sup45) *and* verbalising the word "timeout" are both necessary under these circumstances.

- (ii) When the ball is dead and there is no threat of action on the field, a verbal request to the nearest official will be sufficient.
 - (iii) Under no circumstances shall an official stop the clock unless they are certain that the request comes from the *head* coach. If the official is unsure whose voice requested the timeout, and is unable to turn round to find out, no timeout will be granted.
 - (iv) Before the snap, anticipate a coach asking for a timeout when you know their team is a player short or looking confused. At the end of a play, anticipate a coach or player asking for a timeout when the game clock is running and their team wants to conserve time.
 - (f) **Coaches on the field during timeout:** During a charged timeout, coaches who come on to the field less than 9 yards from the sideline and do not go beyond the 20-yard lines are not normally to be regarded as a problem unless their behaviour draws attention to themselves.
5. **Trick plays:** Be very strict in penalising trick plays that constitute unfair tactics. Such plays include (but are not limited to):
- (a) trick plays depending on the ball being concealed or substituted (Rule 9-2-2-a);
 - (b) trick plays associated with simulated substitutions, particularly "hiding" a player near the sideline on their team's side of the field[§] (Rule 9-2-2-b);
 - (c) trick plays involving players' equipment (Rule 9-2-2-c);
 - (d) trick plays where Team A runs a "normal" play having informed the opponents that it would be "taking a knee" (see also 3.8.6.c below) (Rule 9-2-2-d);
 - (e) trick plays with actions or verbiage designed to confuse the defense into believing the snap or free kick[§] is not imminent (Rule 9-2-2-d) – this includes pretending to have a problem with the play that has been called, an equipment problem with a shoe, the ball, etc. and feigning an injury (Rule 9-2-2-e); it also includes assuming the role or functions of an official.

Rules of thumb:

- (i) If an unusual act appears to be unfair, it is probably contrary to the rules.
 - (ii) Relevant to simulated substitutions is to ask yourself, "Could the team have equally well run that play on the other side of the field?". If the "simulated" replaced player was moving towards their own team area, this is more suspicious than if they were moving towards their opponent's team area. [§]
6. **Take a knee plays:** When Team A informs the officials that they intend to "take a knee" (sometimes known as the "victory formation"):
- (a) Ensure that Team B is informed.
 - (b) Remind Team A that Team B will still be able to stop the clock if they have timeouts remaining.
 - (c) Remind Team A that they will be penalised (under Rule 9-2-2-d) if they subsequently run a "normal" play after having declared their intention to "take a knee" (see also 3.8.5.d above). This includes not taking a knee immediately (*less than 3 seconds*)[®] after controlling the snap.
 - (d) Remind Team B of Team A's declared intention on each subsequent play, unless Team A informs you that they will run a normal play, in which case inform Team B of that.
 - (e) Warn Team B not to "punish" opponents or otherwise attempt to interfere with the process (other than in a legitimate attempt to gain possession of a loose ball).
 - (f) All officials may choose to change their initial position for the snap. By "pinching in" closer to their nearest player(s), they may be in better position to deter, prevent or de-escalate any aggressive actions. [§]
 - (g) Penalise players from either team who try to take advantage of the situation to either gain yards (Team A) or punish an opponent (Team B normally). If Team A consumes time unfairly, Rule 3-4-3 may be used to restore time to the game clock.
 - (h) If the score is close, then Team B has a legitimate right to attempt to gain possession. However, if the margin in the score is wider than could reasonably be overcome in the time available, Team B should not instigate any forcible contact.
 - (i) If Team A line up in a "victory formation" but do not inform the officials or Team B that they intend to take a knee, this guidance does not apply and Team A may equally legally run a "normal" play or take a knee (at their risk).

7. **Inadvertent whistle:**[§]

- (a) The overall philosophy for the rules on inadvertent whistles (and their application) is to reset the state of the game as closely as possible to what it would have been had the inadvertent whistle not been blown. Also, part of our philosophy is that we do not want what is an officiating mistake to cancel out either a piece of exceptionally good or exceptionally bad play by one or more players, whenever possible. An inadvertent whistle should be as inconsequential as possible.
- (b) When an inadvertent whistle occurs just before the ball would anyway have become dead, the exceptions in Rule 4-1-2-b provide effective mechanisms by which the next play would be the same (or close to) what it would have been had the whistle not been blown. This is also the case when a foul has occurred (Rule 4-1-2-c).

- (c) When an inadvertent whistle is followed by a dead-ball situation not explicitly covered by an exception in Rule 4-1-2-b, if there is a plausible opportunity to apply one of the parts of Rule 4-1-3 (for example, Rule 4-1-3-s) in preference to Rule 4-1-2-b, do so. That will minimise the consequences of the inadvertent whistle, perhaps to zero.
- (d) When an inadvertent whistle occurs early or in the middle of the intended play, the fairest outcome is usually applying the relevant section of Rule 4-1-2-b that leads to the option of the down being repeated (unless the dead-ball spot is advantageous to the team in possession).

(e) **Continuing action:** After an inadvertent whistle, if one or more players² in the vicinity of the ball continue to play the ball, regardless of the time, then that is the immediate continuing action. This period stretches as long as those players in the vicinity continue to play the ball, regardless of what other players do on the field.

8. **Dealing with disqualifications:** A disqualified participant must leave the playing enclosure (Rule 9-2-6-b) within a reasonable amount of time. Provided they are making progress towards leaving at a reasonable rate, the game should continue. However, the game may need to be suspended if the disqualified participant attracts attention or delays their departure. The offending team is responsible for escorting their participant away and may be penalised (for delay of game) if this is not achieved. If the disqualified participant or the person(s) responsible for them commits a (possibly further) unsportsmanlike act, this should be penalised.

3.9 - When in doubt principles

If you are reasonably sure of something, then go with that – it is more likely to be correct than to fall back on the relevant "when in doubt" principle. However, the "when in doubt" principles reflect experience that, in certain situations, one outcome is more common than the other. Therefore, by going with the more common outcome, you are more likely to be correct, but that is not guaranteed. The principles are not there to excuse failing to apply the correct mechanics.

Note that the principles below do *not* change when video review is available. Given the quality of video we will most often see, it is likely that many reviews will let "stand" the call on the field, so it is important to make the call on the field as fair as possible.

When in doubt:

Pre-snap

1. offensive players are legally on the line;
2. offensive players are legally in the backfield;
3. defensive signals are legal;
4. a departing player has left the field prior to the snap;
5. a charged team timeout precedes a foul that prevents the snap;
6. the one second pause after a shift has been violated;
7. players are legally moving rather than in illegal motion;
8. it is a false start rather than illegal motion;[§]
9. an eligible receiver is not covered up on the line of scrimmage;[§]
10. when a Team B player moves into the neutral zone before the snap and causes a Team A player to react, the movement *is* towards the Team A player;[§]
11. when a Team B player aligned right to the line of scrimmage jumps forward and causes a Team A player to react, the Team B player *was* in the neutral zone and is the one penalised;[§]
12. when a Team B player shoots the gap between Team A linemen, there *was* contact causing an offside foul;[§]
13. a quick or abrupt movement by the snapper or quarterback is a false start;[§]

Blocking

14. the back at the snap is not positioned outside the normal tackle;
15. as to disintegration of the free-blocking zone (Rule 2-3-6) or tackle box (Rule 2-3-4), they are intact;
16. a block below the waist occurred before (not after) the ball left the tackle box
17. it is a legal block rather than clipping;
18. the contact is below the waist rather than above it (Rule 2-3-2);
19. a blind-side block is legal rather than illegal;
20. as to a block in the back, the contact is at or below the waist rather than above (Rule 2-3-4-a);
21. it is legal use of hands rather than holding or illegal use of hands;

Passing

22. the forward pass is incomplete rather than a fumble;
23. the forward pass is catchable (Rule 2-19-4);
24. it is a fumble rather than a forward pass if the passer was hit from their blind-side, or if you see an empty hand moving forward, otherwise the passer has thrown the ball rather than fumbled it (Rule 2-19-2-c);
25. the passer has not intentionally grounded the ball;
26. the pass is forward rather than backward behind the neutral zone (Rule 2-19-2-a);
27. the pass is backward rather than forward beyond the neutral zone or when there is no neutral zone;
28. the forward pass was thrown or forward hand-off made from in or behind rather than beyond the neutral zone;

29. the forward passer is (or has been) outside the tackle box;[§]

Possession and touching

- 30. a catch, recovery or interception is not completed (Rule 2-4-3-h);
- 31. as to whether the ball touched the ground during a catch, it did not touch the ground;
- 32. on a simultaneous catch or recovery, whoever comes up with the ball gets it;
- 33. it is a fumble rather than the running play has ended;
- 34. as to touching the ball, a player has not touched it (Rule 2-11-4);
- 35. the ball is accidentally touched rather than intentionally batted or kicked (Rules 2-11-3, 2-16-1-a and 2-16-1-d);

Kicks

- 36. with respect to kick-catch interference,[°] a kicking team member has (a) entered the area in front of the receiver; (b) contacted the potential receiver before (or simultaneous with) their first touching the ball; (c) interfered with a receiver in position to catch the kick and who does not do so;
- 37. if it occurs close to the time of the kick, a foul by a Team B player trying to get to the kicker will have previous spot enforcement; a foul by a Team B player trying to aid the return will have postscrimmage kick enforcement;
- 38. a foul by Team B on a scrimmage kick occurred after (not before) the ball was kicked;
- 39. the kicker is outside the tackle box;[§]
- 40. it is not a scrimmage kick formation;[§]
- 41. a kicking team player has not broken the plane of their restraining line;[§]

Ball live/dead

- 42. the ball is dead (Rule 4-1-3-a);
- 43. the player is in bounds rather than out of bounds;
- 44. if the ball carrier is being held by only one player, the ball is still alive; if held by two or more, forward progress is stopped;
- 45. an unsportsmanlike conduct foul occurred while the ball was dead rather than live;
- 46. the ball was dead rather than the whistle was inadvertent;[§]

Contact and fouls

- 47. a player is defenseless (Rule 2-27-14);
- 48. the defensive back has legally initiated contact in passing situations;
- 49. the face mask, chin strap or helmet opening has been grasped then twisted, turned or pulled (Rule 9-1-8-b);
- 50. the foul is roughing rather than running into the kicker (Rule 9-1-16-a-8);

Near the end zone

- 51. it is a touchback rather than a safety (Rule 8-5-1-a);
- 52. it is a touchback rather than a momentum exception;
- 53. the ball is dead in the field of play rather than a touchdown;
- 54. as to whether an illegal block or other illegal act[§] occurs in the end zone or field of play, it occurs in the field of play;
- 55. on changes of possession in or near the end zone, the return has NOT left the end zone;
- 56. Team B caught or recovered the kick in its own end zone rather than in the field of play;
- 57. the kick was touched in Team B's end zone rather than in the field of play;
- 58. if there is a change of possession in the end zone (or the momentum exception rule applies), during the return the ball has not left the end zone;

Miscellaneous

- 59. call timeout for injured players;
- 60. an injury was observed before the ball was spotted;[®]
- 61. the Referee should invoke Rule 3-4-3 (unfair clock tactics) when the game clock is under 5 minutes of each half;
- 62. there is no foul;
- 63. don't throw the flag;
- 64. don't blow the whistle.

4. PRE-GAME CHECKLISTS

4.1 - Before the day checklist

In the days prior to the game each official should check:

1. the location of the venue
2. the kickoff time
3. the time the crew is going to meet
4. the location where the crew is going to meet
5. who is going to travel together (particularly to minimise expenses)
6. the competition regulations applying to the game, including its duration and whether extra periods may be played
7. the weather forecast for game day
8. the type of field surface (grass/turf)
9. whether there is history between the two teams
10. the results of each team's recent games
11. what colour uniform each team will be wearing
12. who the Head Coach of each team is
13. whether any personnel from either team are serving suspensions
14. contact details for other members of the crew
15. their radios and other electronic equipment are fully charged
16. the schedule for pre- and post-game activities
17. [how their personal nutrition and hydration needs will be met[‡]](#)

In addition, for an international game, and/or one where unusually long travel is involved, and/or where an overnight stay is required, each official should check:

18. their travel arrangements
19. their accommodation arrangements
20. any pickup or dropoff arrangements to/from airports, hotels, the stadium

4.2 - Game management checklist

At the earliest possible opportunity after arriving at the venue, the officials should check all appropriate items from the following list with the representative(s) of game management:

1. adequacy of playing area, field markings, padding of posts, removal of hazards, etc.
2. jersey colours
3. confirm kickoff time
4. the time the teams will enter the field
5. whether a player identity check is to be performed and, if so, when and by whom
6. stadium clocks and clock operators
7. public address announcer
8. team announcements and the time they will begin and end
9. any VIPs or special arrangements for coin toss ceremony
10. national anthems
11. half-time activities, length of interval, etc.
12. end of game activities
13. public radio
14. payment of game fees
15. chain, chain crew and the time they should be available
16. balls, ball persons and the time they should be available
17. towels
18. medical facilities
19. changing room security
20. if the officials can have a copy of the game video
21. whether drinks will be provided for the officials at half-time and the end of game

4.3 - Team checklist

At least 60 minutes before kickoff, the Referee or other officials should check all appropriate items from the following list with the Head Coach and management of each team:

1. player numbering/eligibility
2. player equipment
3. everyone in the team area has appropriate credentials
4. roster form
5. numbers of captains

6. whether all quarterbacks are right-handed
7. whether all kickers are right-footed
8. number of the long snapper(s)
9. unusual plays, formations or situations
10. who will be their team's first responder(s) to injured players
11. rule queries
12. sideline control, including the name of the "get-back coach"
13. procedure for calling for a timeout or coach's conference
14. procedure for calling for a replay review

4.4 - Medical checklist

Before kickoff, the officials should check all appropriate items from the following list:

1. location of medical personnel during the game
2. signals to be used to summon medical help to the field

5. GENERAL PRINCIPLES

It is said that officiating is as much an art as a science. The "art" comes from knowing what tools to pull out of the officiating tool bag at any particular point in the game. That comes from experience, but top flight officials also understand that there are a basic set of principles that underpin officiating in general and officiating American football in particular. These include:

- common sense;
- your personal conduct;
- dealing with media;
- knowing how to work with colleagues;
- what we mean by consistency;
- being mentally prepared;
- recognising pivotal points in the game;
- dealing with uncertainty;
- being able to sum up a philosophy in a few words;
- what it means to be effective as an official;
- as well as lessons learned by officials from other sports.

These are all covered in the following sections. §

5.1 - Common sense officiating

1. It is important that you call every foul that you see which is conspicuous or affects the result of the play, the safety of the players, or the discipline of the game. However, please remember that neither spectators nor players come to see officials marching up and down the field. Use your discretion, and above all your common sense. Delay throwing the flag for a second or two to give yourself time to review the situation mentally.
2. Preventive officiating enables a game to flow in a disciplined manner. Whenever necessary, talk to coaches or players with regard to their conduct. Never *ignore* a foul: you must do something about every foul. Even if you decide not to throw your flag, talk to the player(s) involved. **Do not admit that you saw a foul but did not call it - it is better to tell the player that it was "nearly" a foul.** @
3. At appropriate times, such as when the players are lining up for a kickoff or leaving the huddle to go to the line of scrimmage, remind players to check their mouthpieces and chinstraps, and also to use their hands legally. Try not to be obtrusive about doing this.
4. Always acknowledge complaints from players. You cannot see everything on every play. If a player makes a complaint against an opponent, be prepared to observe the next encounter between them more closely. Request the assistance of other officials when necessary, but don't delay the game in making such a request.
5. When speaking to players, coaches or spectators always be polite. Your position as an official does not give you the right to be abusive or derogatory. Use soothing language to defuse hostility.
6. When you have made a decision based on your observation, your experience and your knowledge, do not back down. Pressure from coaches, players, or the spectators should not be allowed to influence your judgment. When you are wrong, admit it, but don't allow it to affect your performance.
7. Praise players for good sportsmanship, but make sure you do it to both teams.

5.2 - Officials' conduct

1. Remember that your conduct before, during, and after each game is subject to public scrutiny. Always conduct yourself in a manner befitting an official.
2. Officials bear a great responsibility for engendering public and participant confidence. You are judged by everything you do, on the field and off it, before, during and after the game. Greet and treat the personnel from each team equally. Don't banter with spectators. Don't fraternize with anyone.
3. **People's first impressions of you as an official will often stick. That is why it is important at all times to look the part. This includes:**§
 - (a) you turning up on time;
 - (b) your uniform and equipment being complete and clean;
 - (c) your physical appearance being reasonable;
 - (d) you appearing friendly and approachable;
 - (e) you acting like an official at all times when on duty.
4. **With video streaming and recording becoming more and more common, officials have a responsibility to think about how their actions will look on screen. We are not trying to make all officials look the same, nor are we saying that emotions can't be displayed, but it sometimes does not take much to provoke a negative reaction from observers such as players, coaches and spectators. Possibly undesirable actions include:**§
 - (a) Gestures to anyone (including other officials) that are open to a negative interpretation.
 - (b) Touching a player, coach or sideline personnel.
 - (c) Fidgeting or unusual habits.

- (d) Showing anger, for example when throwing a flag.
- (e) Inappropriate speech that might be picked up by a microphone.

5. Perform warm-up exercises before the game
 - (a) preferably in the privacy of the changing room, if not
 - (b) out of sight of spectators, if not
 - (c) well away from players.
6. Do not test your whistle on or within hearing of the field of play. Do not toss footballs around or indulge in any other recreational activity in sight or sound of spectators, players or other personnel.
7. Do not consume alcohol or any prohibited drug, or be under the influence of either, before, during or immediately after a game.
8. Do not provide any team, coach or player with any information pertaining to any other team, coach or player. Do not carry gossip from one team to another, nor make statements about another crew or another official.
9. Do not engage in arguments with anyone after the game regarding any decisions made. If they wish to complain, refer them to [your officiating organisation](#).⁴ Questions of judgment on the part of any official are not open to argument either on the field or after the game.
10. Be loyal to your fellow officials, to your officiating organisation and to football.
11. Report immediately to [your officiating organisation](#)² any approach by anyone regarding the possibility of an attempted bribe or any other unethical act.

5.3 - Dealing with the media

1. Always be courteous when dealing with the news media, but remember that your job is officiating and that you are not a spokesman for any team, league or officiating organisation.
2. You may at any time, except in the emotion-charged atmosphere of a game or its immediate aftermath, explain and discuss a rule. Do not, however, discuss a particular play, ruling or interpretation except after the game to answer specific questions from reporters attending the game. [This should not be done to camera nor recorded for subsequent broadcast](#). The best place to do this is in or immediately outside the officials' dressing room. Be sure the crew discusses the play in private, and makes sure all the facts are clear, before the Referee talks to the reporters.
3. [The above is intended to provide reporters with information about a call and the rules related to it. It is not for the reporters to debate the call or question the officials' judgement.](#)

5.4 - Philosophy of crews of 6, 7 and 8

1. The basic principles of officiating for crews of 6, 7 or 8 remain the same as those of crews of 4 or 5, however the addition of [one, two or three](#)⁴ extra officials can be an advantage or a disadvantage. It is obviously an advantage to have extra pairs of eyes on the field, maintaining order in fringe areas and giving additional perspectives on key plays. The disadvantages occur if the additional officials simply duplicate the responsibilities of the existing officials, leading to two officials ruling on the same play but potentially in contradictory fashion. Alternatively, there may be a situation where two officials each leave a tough call to the other and the indecision causes the right call to go unmade. It is thus even more crucial on a larger crew that communication is effective and that areas of responsibility are well defined.
2. Having extra officials makes it easier for a crew to detect rules infringements. This better protects the safety of the players and decreases the chances of a team obtaining an unfair advantage. It should not be the aim of a larger crew to call more fouls, rather the extra officials should provide more opportunities for preventive officiating, as well as having a greater deterrent effect. This should in the long run reduce the number of fouls.
3. The more officials there are, the easier it should be to detect illegal action away from the ball. It is much less likely that extra-curricular activity will occur undetected.
4. It is likely that there will be a significant number of plays where some officials, particularly the ones deep downfield, are not directly involved. As one of those officials, you must therefore be prepared to concentrate on your cleanup role, and remain alert for the time when the play does come in your direction, because when it does it is likely to be a big play like a long pass or crucial kick. You can also contribute to the better administration of the game by keeping yourself involved in such duties as relaying balls, controlling sidelines, covering flags and checking penalty enforcement.
5. With a larger number of officials, as a wing or deep wing official, it is possible for you to concentrate for longer on the action by and against eligible receivers. On a crew of 7 or 8, you should only have to key on one receiver which should make it impossible for any foul play involving them to go unobserved. Similarly, as the play develops, you will have smaller zones to deal with and should therefore be able to provide better coverage.
6. As a deep wing official (or the Back Judge on a crew of 7 or 8), you must always try to stay deeper than the deepest player in your area (except [Field Judge/Side Judge](#)² when you have goal line responsibility). By keeping the players boxed in between you and the wing officials, the play can be covered from front and back, providing optimum coverage.
7. As the size of the crew increases, there is more chance that your initial position will be nearer the place you need to be to make a call, thereby reducing the need for you to make the call while moving at top speed. A larger crew is not however an excuse for you to remain stationary.

8. When you are one of two officials covering the same sideline or end line, it is crucial that you establish eye contact with your colleague to communicate your ruling to each other before giving any overt signals.
9. When you are one of two officials covering the same intersection of two lines (e.g. at a goal line or end line pylon), you should concentrate on the crossfield line (i.e. the end line or goal line) if you are on that line, and leave the primary responsibility for the sideline to your colleague.
10. Occasionally, three officials will find themselves covering the same crossfield line. In this case, if you have another official (almost certainly with their back to you) between you and the ball, don't stand behind them and don't repeat their signals (except timeout, [S3]).
11. While only a minority of officials may be working in crews of 6, 7 or 8 regularly, it is the responsibility of every official to be familiar with these mechanics so that they can take an effective place on a playoff or other assignment covered by a larger crew.

5.5 - Consistency

Officials are often criticised for lack of "consistency", but often what the critics mean is not what we are actually striving for.

1. Aspects of consistency that we do strive for include:
 - (a) decisions made in the 1st quarter should be the same as decisions made in the 4th quarter (with the exception of "blowout" games)
 - (b) decisions made for/against the home team should be the same as decisions made for/against the away team
 - (c) decisions made on one side of the field should be the same as decisions made on the other side
 - (d) decisions made for/against players of high ability should be the same as decisions made for/against players of lower ability in the same game
 - (e) all officials on the same crew should interpret the rules the same way (but this may vary in practice according to their experience)
 - (f) all officials participating in the same tournament should interpret the rules the same way
 - (g) the application of standard mechanics
2. Aspects where we do not require consistency include:
 - (a) decisions made when the facts of the case are different - *no two plays are ever exactly the same*^o
 - (b) calls in high-level (e.g. international or national premier league) games need not be the same as calls in lower-level games
 - (c) similarly, we do not require consistency of interpretation between senior and junior/youth games
 - (d) calls made while the attitude and conduct of players is positive need not be maintained when the same players switch to a less desirable attitude
 - (e) mechanics in unique or unusual situations
3. Aspects where we would like to achieve consistency but accept that we cannot reasonably expect it with our current resources include:
 - (a) decision making by officials of differing experience
 - (b) all officials working in different countries or different parts of the same country interpreting the rules exactly the same way

5.6 - Mental preparation

Acknowledgement: This section is based on material produced by The Football Association for its match officials.

1. Top officials are those who (among their other skills) can overcome the mental pressures of a tough game. They can ignore the crowd or the importance of the occasion, or even feed off them to improve their performance. For most people, the mental pressure comes from within: it is their own reading of the situation which causes pressure, and because it is from within it can be controlled. The winners are not necessarily born this way but have trained themselves both mentally and physically.
2. Consistency comes from the ability to focus on the game and ignore internal and external distractions and apply the rules correctly in each and every situation.
3. The ideal official is:
 - (a) calm under pressure
 - (b) in control of their emotions
 - (c) confident
 - (d) mentally alert
 - (e) positive
4. The good official does not try to avoid pressure, rather they accept that it is part of the game at all levels. Be confident that you have the skills to deal with the situation. Pressure is not a threat but a challenge to be welcomed.
 - (a) Do not get upset by the challenge of the players to your decisions; they are not directing their anger at you, they don't know you! Their frustration is directed at the uniform – the authoritative role you represent.
 - (b) Do not get upset by mistakes or under-performance by your fellow officials. Remember, you were inexperienced once and even now you still make mistakes from time to time. Calmly put right those mistakes that can be corrected by rule. Gently inform colleagues who practise incorrect mechanics.

- (c) Show no anger, no fear, no negative emotions. The only emotion allowed to show itself is enjoyment, and remember, that is what we are there for!
 - (d) Be strong in your decision making, take responsibility and manage the consequences whether your decisions are right or wrong.
 - (e) Be confident, assertive but not arrogant, have a determined belief in your own ability that you can perform well. This means you will not be intimidated by the pressures of the occasion or by the antics of the players.
 - (f) Be able to maintain concentration on the things that matter in the game, and have the ability to "switch off" no matter what the pressure.
5. How do you learn to officiate under pressure? The answer is: you don't. Nobody performs well "under pressure" – the reason why our top officials at all levels of the game "shine" when the stakes are highest, the competition the fiercest and the game the toughest is not because they can do it under pressure, but because they eliminate the pressure and officiate in an "ideal mental state".
6. When you are officiating at the ideal mental state:
- (a) you feel relaxed although the adrenaline level is high;
 - (b) you feel a little nervousness but with a sense of calmness and confidence;
 - (c) your decisions will be made spontaneously without conscious thought process as you will have a strong belief in your ability;
 - (d) you will always feel as if you are in the right place at the right time;
 - (e) you will maintain concentration and have an awareness of what is happening around you;
 - (f) you will maintain control over your emotions and not become tense, therefore remain in total control of yourself.
- If you manage the above, you will eliminate the excess of "pressure" which would otherwise prevent you from performing at your best.
7. Preparing mentally for a game:
- (a) Don't change your physical preparation, i.e. continue any physical training at your usual level, and do not change your pattern of relaxation as this is equally as important as your physical preparation.
 - (b) Do prepare yourself mentally for anything which might happen.
 - (c) Don't try to make changes to your refereeing technique. What you have done so far has been good enough to give you the opportunities you are receiving. Only make changes to your identified areas of development.
 - (d) Do a little mental rehearsal every day; see yourself refereeing in an ideal mental state.
 - (e) Don't become anxious about your nerves, you will need an adrenaline flow for the game, so look forward to the 'buzz'.
 - (f) Do anticipate that you will enjoy the game. You are going to perform well; you are going to be in control; you are going to handle any situation that arises.

5.7 - Pivotal plays

1. In any game, there are likely to be a number of plays which are *pivotal* – i.e. they are important because they may make a significant difference to the game, perhaps by giving one team an advantage. You must learn to recognise pivotal plays so you can respond appropriately. Most plays are "routine", involving small gains or losses, but even a routine play may be pivotal to the conduct of the game if it sparks a confrontation between players, involves an injury, or comes at a critical time.
2. Plays that are often pivotal include:
 - (a) all types of scoring play
 - (b) changes of possession
 - (c) fourth down plays where Team A go for it
 - (d) third down plays that end close to the line to gain
 - (e) all plays in a close game when time is short
 - (f) trick plays
3. Recognising a pivotal play may occur before the snap, for example:
 - (a) Team A's substitutions or formation indicate that something unusual is likely to happen
 - (b) Team B's substitutions or confusion indicate that they may not react normally to the play
 - (c) Team A take an unusually long time to call the play and/or the coach is more involved than usual
4. Recognising a pivotal play may occur during the play, for example:
 - (a) the play ends near to the goal line
 - (b) the play ends near to the line to gain
 - (c) a fumble occurs during the play or the ball becomes loose from a backward pass
 - (d) it is difficult to tell whether the pass was complete or incomplete
 - (e) it is difficult to tell who first touched a kick
 - (f) one or more players become very emotional during it
5. A play may become pivotal because of a foul called during it. This is especially the case when the penalty negates a score, a change of possession, a long gain or a big loss.

6. You need to respond differently to a pivotal play. This might include:
 - (a) getting closer to the action
 - (b) selling the call conspicuously and decisively
 - (c) taking time to cool frayed tempers
 - (d) communicating more clearly both verbally and by signals
 - (e) repeating communications
7. Conversely, you should try not to oversell routine plays. If you do that, you will lose your ability to sell pivotal plays.
8. A play that pivots the game towards one team may turn out to actually pivot it towards the other, once a penalty is taken into account. This is likely to generate especially strong emotions.

5.8 - Dealing with uncertainty

1. Uncertainty (or doubt) is a common and normal part of officiating. You perhaps only see a glimpse of some action, because it is obscured by other players, because the action happens so fast, or because it had started to happen before your gaze was focused on it. It is not something normally to worry about, because we have tools that we can use to resolve uncertainty, the primary ones being communication and principles.
2. Uncertainty should trigger an attempt to gain more information, either by adjusting your position and view, or by communicating with another official. Sometimes the actions of the players convey information about what *they* believe happened during the play, giving you additional evidence to help you make the call.
3. It helps to be able to quantify uncertainty. The following scale (used by the UK Government during the COVID pandemic) defines the words to use according to how certain/uncertain you are when communicating with colleagues (ranging from "remote chance" to "almost certainly"):

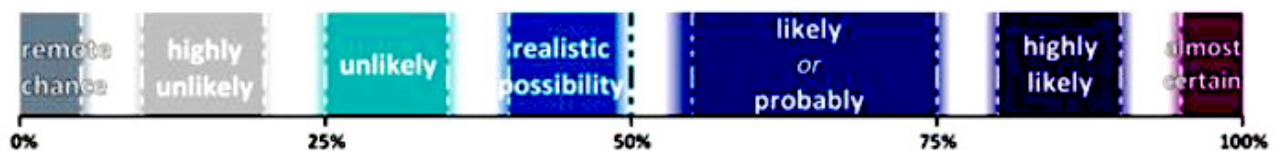

5.9 - Points to ponder

Always remember:

1. player safety is your number one concern after your own;
2. make the tough call;
3. don't get emotionally involved;
4. a pre-game conference is a must;
5. if you look like an official you'll perform like one;
6. count the players;
7. correct obvious errors;
8. see leather;
9. know the down and distance;
10. sell the call but don't over-officiate;
11. call what you see but see what you call;
12. don't guess – know;
13. if two officials are marking a spot, one could be doing something else;
14. let the mind digest what the eye has seen;
15. what effect does it have on the play?;
16. it's what you learn after you know it all that counts;
17. on the wings, don't get trapped inside;
18. in the defensive backfield, don't get beat deep;
19. after throwing your flag, continue to officiate;
20. 4th down, kill the clock;
21. take a second to take a look;
22. the three virtues of a good official are attitude, consistency and competence;
23. the only part of officiating to emphasize is your signalling;
24. be decisive – indecision (or is it indecisiveness?) gives the impression of uncertainty;
25. never stand still during an entire down – people will think you are lazy;
26. if officials are close enough to touch each other there is generally something wrong;
27. don't get mad and don't get even;
28. if the fans and coaches don't know your name or who worked the game, you've had a great game;
29. it is more important to get it right than to look good;
30. don't dillydally – if you are going to get it wrong it is better to get it wrong quickly than it is to get it wrong slowly, but it's still better to get it right;
31. false pride has no place in officiating;
32. there are probably 5 "big" calls per game – make sure you get them right;

33. officials can **influence** people (affect their behaviour) because they have **power** (the ability to influence someone), and **authority** (the right to exercise power), but there can be no authority without respect for that authority, and respect has to be earned – it does not come automatically with the stripes;
34. if you are not *sure* it's a foul, it isn't, except against the QB;
35. if they get beat, they cheat!
36. there is no such thing as a *late* flag, only a *considered* flag;
37. ignorance can be corrected, but stubbornness and stupidity might be permanent;
38. getting the job done is better than doing it perfectly;
39. don't officiate at 100mph – you will see more if your head is steady;
40. it doesn't matter how fast you are moving, light will still reach your eyes at the same speed;
41. you spend far more time officiating when the ball is dead than when it is live;[§]
42. if you don't deal with inappropriate behaviour, someone else will have to do it later and by then it might be worse;[§]
43. you're only as good as your next call.

5.10 - Principles of effective officiating

You must:

1. be helpful (preventive officiating);
2. have a thorough pre-game conference;
3. be prepared to compromise;
4. **make yourself available**⁴ to other officials;
5. help fellow crew members as much as possible;
6. encourage less experienced officials to ask questions;
7. give advice when needed;
8. be on time;
9. know **your**² position;
10. know that uniformity **and consistency are**[§] important;
11. act in a professional manner at all times;
12. be aware of primary and secondary responsibilities;
13. be people watchers not ball watchers;
14. be clock conscious;
15. never miss a down;
16. **recognise pivotal plays**,[§]
17. give good signals;
18. not allow **participants**⁰ to trash talk to opponents;
19. be in the position to make the call;
20. not turn **your**² back to the ball;
21. blow **your**² whistle like **you**² mean it;
22. **take your**² time in retrieving a ball after a play - other more important things must be dealt with first
23. keep **your**² mouth closed around the goal line;
24. keep up-to-date with the mechanics of crews smaller than you normally work – you never know when injury or delay will force you to work that way;
25. be able to control **your**² sideline;
26. be able to cover situations far downfield;
27. be aware of tempo;
28. know penalty enforcements;
29. never alienate a member of **your**² crew;
30. "make it be there" – no phantom calls;
31. "get the play right";
32. **communicate with colleagues when in doubt.**

5.11 - Ten tips from Sports Officials UK

1. Know the rules and rules applications and apply them accurately. That way you will achieve the consistency that competitors need.
2. Be decisive and strong in your decision making. Competitors will trust decisions made confidently and assertively but not aggressively.
3. Make sure the players understand your decisions. Then you will reduce their reasons to challenge them.
4. Don't take challenges personally. Questioning your decision is not an attack on your integrity.
5. Watch for flashpoints. If you see what might cause an outburst you can prevent it.
6. If you get a decision wrong, acknowledge it. Players accept you are human – they don't trust perfection.
7. Don't try to redress injustices. Apply the rules, and let justice take care of itself.
8. Be friendly and approachable. Players will relate to a person more than they do to an official.
9. Give every event your best effort. For some competitors this is the highlight of their season.
10. Enjoy your officiating. If you don't enjoy being there, the competitors will know.

6. GENERAL MECHANICS

6.1 - Duties and responsibilities

General priorities (highest first):

1. Having a thorough knowledge of the duties of your own position.
2. Being aware of the duties of each of the other officials.
3. Being prepared and able to assume any one of the other positions whenever circumstances, such as injury or delayed arrival, require rearrangement of assignments.
4. Knowing the prescribed signals and when and how they should be used.
5. Being able to handle and pass the ball properly underarm up to 10 yards with a flat trajectory and nose first.

Specific duties during the game (in no particular priority):

6. Knowing the down and yardage prior to each snap.
7. Being ready to assist any official who is out of position.
8. Securing a new ball, if appropriate, after all action has ceased.
9. Being alert to happenings away from the ball when play has left your immediate area.
10. Calling time out for any player who is obviously injured.
11. Being prepared, if necessary, to call any serious foul or rule infraction that you observe, regardless of specific assignment.
12. Observing incorrect procedures or rulings by other officials and attempting to prevent and/or correct them whenever possible.
13. Communicating with colleagues, players, coaches, announcers or spectators as appropriate whenever anything unusual or out of the ordinary happens.

14. [Communicating with colleagues when in doubt.](#) [®]

6.2 - Tempo and injuries

1. Always try to keep the game flowing smoothly, but do not rush. Move quickly when required, but do not allow your desire for rapid action to interfere with your duties nor with correct determinations.
2. Jogging (slow running) into position almost always looks better than walking.
3. When moving into position for the next down, keep facing the ball. This may enable the Referee to declare the ball ready for play sooner, and thus speed up the game tempo. It will certainly prevent you being surprised by a quick snap and improve your ability to spot extracurricular activity.
4. When players are getting angry or frustrated, you may need to slow down the tempo of the game in order for them to cool off or have an opportunity to speak to you or their teammates (legally). Alternatively, a slight increase in the tempo of the game may be beneficial in forcing them to concentrate more on playing and less on talking. Use your experience to decide which is the appropriate course of action in a given circumstance.
5. Particularly in hot weather, encourage players to drink water during stoppages in play by reminding them of the opportunities. *Never* call a Referee's timeout solely for the purpose of allowing players [or officials](#)[◊] to take in water. Stopping the game at an arbitrary point will always benefit one team over the other in terms of momentum. Instead, use the opportunity of an injury or penalty enforcement to allow players to go towards the sideline for a quick drink.

Injuries:

6. The recognition of injured players is the concern of all game officials.
 - (a) If in doubt about a player who is on the ground, signal timeout [S3] and call the attention of the medical personnel present.
 - (b) If in doubt about a player who is still on their feet, ask them if they are OK. If they do not answer in the affirmative after asking twice, stop the clock as they are probably in no fit state to continue.
 - (c) [The responsibility for stopping the clock for an injured player rests with the official who first spots that the player may be injured. This may be the nearest official, but not always, particularly when the player is out of view of the nearest official. Do not overrule an official who is in a better position than you to evaluate the state of a player, unless an egregious error has been made.](#) [§]
 - (d) [In the closing seconds of a half, take care not to grant an injury timeout that would enable Team A to run an additional play that it would not otherwise have time to do. A player's condition is unlikely to get worse in a few seconds, unless it is an immediately life-threatening condition. Allowing the period to end will not significantly delay medical attention.](#) [◊]
 - (e) Pay particular attention to participants (players and officials) who may have suffered a concussion. Be aware of the signs of concussion and be on the lookout for them. Anyone who shows signs must leave the field for assessment and may not return to the game unless cleared to do so by a medical professional.
 - (f) Be on the lookout for participants who are bleeding or are blood-soaked. They must also leave the field for attention.
 - (g) The time of an injury is when an official sees it and declares a timeout, not when the injury occurs. It is not necessary to restore time to the game clock if there is a delay in spotting the injury, unless the delay is egregious.

(h) If an injured player is observed before the ball is spotted, even if the injury timeout is only granted *after* the ball is spotted, no timeout should be charged to their team. Crew communication is important to establish when a player was first observed as injured. If in doubt, the injury was observed before the ball was spotted.[®]

7. Good practice in dealing with injured players includes:
- (a) Never hurry the treatment of an injured player.
 - (b) Always act in the best interests of the injured player. This usually involves summoning their team's trainer on to the field to tend to them. If a team doesn't have its own trainer, then the medical personnel provided by game management (e.g. a paramedic or stadium doctor) should be summoned.
 - (c) Other personnel (e.g. a coach or a fellow player) may want to tend to the player while the medical personnel are being summoned. Take care with this, since unless you know they are trained in first aid, there is a possibility (usually remote) that they might make the situation worse. This might particularly be the case if a broken bone or internal injuries are suspected. Nevertheless, allowing these personnel to reassure the player is normally the most appropriate thing to do.
 - (d) Before the game, ask the Head Coach of each team to identify their team's first responder(s) to players' injuries, and whether they are qualified in first aid (or better, are a paramedic, physiotherapist, sports therapist, doctor or nurse).
 - (e) In cases where the player is legally a child, everyone has a higher duty of care towards them. Allowing a parent (or other family representative) on to the field to talk to or reassure the player while they are being examined may be a good thing to do. The need for this normally increases with the severity of the injury, the length of the stoppage and the youth of the player.
 - (f) The official who recognises an injured player should note their number and ensure that the provisions of Rule 3-3-6 are observed.
 - (g) Always follow the advice or instructions of the medical personnel present regarding the removal of players from the field. Don't rush this.
 - (h) Do not resume play while a player is being treated out of bounds within the **safety zone**,[®] or deeper if there is a risk to them and/or the people attending them.
8. Look after your own physical and mental well-being and that of your colleagues. Drink plenty of water, especially in hot weather. **During a charged or injury timeout, other officials may need to temporarily cover the dead ball spot to allow the Umpire or Centre Judge to go towards the sideline to get a drink.**[§]

Hurry-up situations (when the game clock is still running):

9. A hurry-up situation is usually late in the game or late in the first half, but may also be used tactically at other times.
- (a) Team A urgently desires to score before the end of the period. In the fourth quarter, this will be because they are behind in the score.
 - (b) Team A will play with urgency: it will probably not huddle and its players will get into position for the next snap much more quickly than normal. The snap count will typically be short.
 - (c) Team B will probably want to slow the game down to consume time, but will be forced to respond to Team A's increased tempo.
 - (d) The pressure will often lead to mistakes, by players of both teams and (occasionally) by the officials.
10. In such situations, spotting the ball for the next down must be done very efficiently.
- (a) The Umpire (or when a play ends in the offensive backfield, [IN 3xx FORMATION (CREW OF 6C/8)] the Centre Judge or [IN 2xx FORMATION (NO C)] the Referee)[§] must go and get the ball wherever it is inbounds, and act as both Retriever and Spotter (MOFO 6.7). Once the ball is spotted, and unless there is a matching substitution situation, leave it and move to your pre-snap position.
 - (b) Other officials should not handle the ball unless it is handed to them.
 - (c) Anticipate that after a play that ends inbounds, the ball carrier may toss the ball to an official (not necessarily the Umpire) or run the ball to the succeeding spot.
11. Be in position for the next down as quickly as reasonably possible. Don't over-hustle though, and try to keep out of players' way. At the end of a play:
- (a) The Coverer (MOFO 6.7)[‡] should not come into the field unless player conduct requires it or the spot is very close to the line to gain.
 - (b) Other officials should not pinch in on the dead-ball spot as much as usual.
 - (c) Anticipate requests for a timeout from players or the Head Coach. Know positively how many timeouts each team has remaining.
 - (d) [DOWN JUDGE] Make sure the chain crew knows to be ready for the next play as quickly as possible.
12. Anticipate plays that are more likely to score quickly, stop the clock or save time. Be prepared to adjust your response accordingly. Likely plays may include:
- passing of any sort, particularly longer passes and/or passes to the sideline
 - spiking the ball to stop the clock
 - the ball carrier wanting to get out of bounds and the defense wanting to stop them
 - a rapid field goal attempt (the Back Judge, or in extremis the Referee (see 9.8.d.2), may have to rule on it alone)
 - if Team A do score but are still behind, anticipate an onside kick

13. Anticipate that you might have to call fouls that are more likely to occur because of the speed at which things are happening, including:
 - illegal formation, because not all Team A players line up in their correct position
 - [illegal shift/false start](#),⁴ because not all Team A players are set for one second before the snap
 - illegal substitution, particularly by Team B not getting replaced players off the field before the ball is snapped
 - holding or illegal use of hands because players are desperate to limit an opponent's movement (but don't start calling picky fouls)
 - deliberate fouls to stop the clock
14. This is not a time for doing non-essential tasks that would "waste" your time or that of players and coaches who are focused on doing things at pace. For example, it would be inappropriate to spend time warning a player or passing information to the Head Coach. Wait until the clock next stops before notifying players and coaches of the time remaining (Rule 3-3-9-b). Leave your bean bag behind if it would take time to retrieve – you or the ball person can retrieve it later.
15. You may feel a tendency to save time by skipping some normal duties. For example, it is unlikely that either team will make a substitution, so you may feel that counting the players can be skipped. Such shortcuts carry a risk, but are sometimes justified. Don't use a hurry-up situation as an excuse to become lazy and ignore important responsibilities. Don't be caught out when a team (especially Team B) *does* make a surprise substitution, because you must make sure it is done legally. If Team A makes a substitution, Team B must be given their opportunity to respond (Rule 3-5-2-e).
16. Do not stop the game unless there is a clear and serious safety issue that cannot wait until the clock next stops. In particular:
 - (a) Don't stop play just because an official is not perfectly in position. Officials should adapt and officiate as best they can as they move to the best position to cover the play.
 - (b) Don't stop play just because the down box has not yet reached its proper place or shown the correct number. If it isn't at the previous spot by the time the ball is snapped, the [Down Judge](#) should drop a bean bag to mark the yard line.
 - (c) Don't stop play just because the defense is not in position. It's their responsibility to get into position in time.
 - (d) Don't give too much heed to players who may appear winded because they are moving slowly. Genuinely injured players will typically be on the ground. Other players may be exaggerating in the hope that you will stop the game to their team's advantage.
 - (e) [Do stop the game if a player is obviously injured, but remember that there are rules to address unfair advantage gained by this. Injuries that only present after the ball is spotted result in a timeout being charged \(Rule 3-3-6-a-1\). Injuries that are obviously feigned are unsportsmanlike conduct \(Rule 9-2-1-a-1-l\).](#)[®]
17. Avoid situations where either team could blame you for consuming or conserving time. Move briskly, but don't move so quickly that you risk tripping up and making yourself look foolish. Work efficiently; work smoothly; intervene as little as possible. [If you *have* to relay the ball, don't let it hit the ground \(BOG - ball on ground\) \(MOFO 6.7.5\).](#)[§]

6.3 - Boxing in

1. When shifting position during the game, always try to surround the play together with the other officials. A position of "outside looking in" is essential for sideline and end line coverage while the ball is inbounds. Once a player with the ball goes out of bounds, the sideline officials must turn and keep their eyes on them while there is a threat of action against them. Keeping the play "boxed in" should ensure that each play is observed from more than one viewpoint.
2. While the ball is live, don't get too close to the play.
3. [When the ball becomes dead, if you are far away, continue moving towards the dead-ball spot. This creates the impression that you were closer to the play and helps sell any call you make. People's perception of your position is often based on where they last saw you, not where they first saw you.](#)[§]
4. Keep out of the way of the players.
5. [If you are moving, your ability to officiate a play accurately decreases. This is because when you move, your head moves, making it very difficult to focus and process visual information.](#)[°] When critical action happens in your area, try to be in a position where your eyes are horizontal and stationary. This could mean coming to a stop before a pass or kick arrives in your zone. Just slowing down and steadying yourself, especially your head, will help.
6. Generally, there is no need for [you or](#)² any official to watch:
 - (a) The ball while it is in the air (other than a glance to ascertain its direction if it may be coming towards you).
 - (b) The ball after a pass is incomplete.
 - (c) The dead-ball spot once it is marked (MOFO 6.6.1).
 - (d) The ball at the succeeding spot until the [snapper/kicker](#)² is about to touch it (**Exception:** if the wind is strong enough to move the ball).
 - (e) The spot of a foul after a flag has been thrown to it (or level with it).
 - (f) The goal line after a touchdown or safety has been scored.

- (g) The ball after a field goal attempt is scored or missed.
- (h) The sideline or end line after a player has been ruled out of bounds.
- (i) A player who is out of the play and has no opponent near them.
- (j) Substitutes and coaches in the team area.

In each case, there is a need for you to concentrate on something else more important.

6.4 - Co-operation and communication

1. It is essential that the officials work together as a team and that you communicate efficiently with each other for the purposes of effective game administration. Such communication will often be verbal, but where verbal communication is impossible or inappropriate, approved visual signals should be used. [\[USING O2O/CREW RADIO\]²](#) Radios should be used where available, but only in accordance with Chapter 25.
2. You must also communicate where appropriate with players, coaches, spectators and announcers. If a ruling is puzzling or controversial, it is better to take a moment to explain it than for everyone to continue in ignorance. Your aim is to give information before someone needs to ask for it.
3. On the sidelines, ask the Head Coach to appoint someone as the "Get-back coach", responsible for keeping their colleagues and players in the coaching box and team area. They can devote more time than you can to keeping people out of your way.
4. All officials should signal the down number before each down. If there is disagreement, toot your whistle before the snap, signal timeout [S3] and confer with your colleagues to establish the correct number. All officials are responsible for ensuring that the down box shows the correct number.
5. It is never wise to carry your whistle in your mouth. It is too easy to blow an inadvertent whistle. [If you use a finger whistle or your whistle is on a lanyard, raising it⁰](#) to your mouth gives you a fraction of a second extra thinking time in which to decide whether the whistle needs to be blown or not. Even when there is a pre-snap foul, there is not microsecond urgency to get a whistle blown.
6. At the end of a down, if you are the Coverer and you are sure the ball is dead, blow your whistle. It should be blown with authority, not just a peep. Other officials should echo the whistle *only* if it is necessary to end continuing action in their area of coverage. Never be the first official to blow a whistle if the ball is not in your zone of responsibility. Don't toot your whistle unless you have thrown a penalty flag or otherwise need to attract the Referee's attention.
7. If you blow an inadvertent whistle, don't think no one will notice. Continue to blow and make sure the play is killed. Admit your mistake and follow the procedure laid down by rule (Rule 4-1-2-b). [See also the specific sections on inadvertent whistle mechanics \(MOFO 6.15\) and philosophies \(MOFO 3.8.7\).](#)[§]
8. Your body language says more than you think – be aware of it. If you are moving hesitantly (e.g. towards the spot where a catch was attempted), it is a sign that you are not sure of the call and need help. Be aware of such body language signals by colleagues and be prepared to assist them where you can. Never point at players or coaches in a disapproving or threatening manner.
9. Don't shout at people – it indicates your loss of control. Never swear at a player, coach or colleague.
10. The following points illustrate good and bad practice when two or more officials disagree on a call. The goal is to get the involved officials to resolve the matter between themselves, but if they cannot the Referee may have to be the final arbiter of the decision.

(a) Officials who disagree on a call must come together to discuss the matter with each other. Other officials who can offer information or rules knowledge should also be involved. The best place for this conference is at the dead-ball spot or the spot where the contentious matter took place. The conference should be conducted calmly, without raised voices or overt gestures (including pointing). Discussing face-to-face is best [but \[USING O2O/CREW RADIO\] one official should press transmit on their radio so that the rest of the on-field crew and the video judge can hear the conversation.](#)[@] Officials not involved in the conference should keep players away, while maintaining coverage of the dead-ball spot and any other relevant spots.

- (b) Officials should describe what they saw, not just what they are ruling. One official may accept that another had a better view of the play. Make sure that all relevant facts (e.g. whether the ball was live or dead, whether the incident occurred before or after the change of possession) are mentioned.
- (c) Distinguish between issues of fact (e.g. what happened?), issues of judgement (e.g. did it happen intentionally?) and issues of rule (e.g. what does the rulebook say we do in the given situation?). Note the distinction between saying "I saw X" and "I think I saw X". Try to quantify certainty/uncertainty (see section 5.8).
- (d) Cut short the conference once all the officials concerned have given their view and opinion. There is no time for repeated remarks (unless clarification is necessary) and encourage everyone to stick to the point.
- (e) Ideally, the officials concerned will come to their own resolution and notify the Referee.
- (f) If the officials cannot agree on the call, it is normally best to go with the call made by the official with primary responsibility for making it. Going with the call made by an "experienced" official over that made by an "inexperienced" official should not be a factor.
- (g) Remember the "when in doubt" principles in the Rules and in section 3.9.[×]
- (h) Once a final decision has been made, the Referee should signal and/or announce the outcome decisively. The need for the decision to be clearly notified to everyone becomes greater the longer the conference takes. It also helps to sell the call if all of the officials nod their heads in agreement during or at the end of a discussion.

- (i) If an official does not agree with the final decision, they must not make any statement or gesture that would give that impression.
11. All verbal communication between **you and other**[@] officials and with persons subject to the rules should normally be in English. If a translation into another language is necessary, this should normally be given after the English statement. In games where English is the primary language of communication, if a person addresses **you or another**[@] official in a language other than English and the response needs to be shared with others, then it should be translated into English before a response is made. (National federations or officiating organisations may substitute their local language for English for use in domestic games only.)
12. The following are examples of situations where **you or another official are**[^] "involved", even if **you**[^] have not thrown a flag. Communicating **your**[^] knowledge to the rest of the crew (especially the Referee) may well be crucial to getting the call correct.
- illegal touching of a pass or kick
 - incorrect clock operation
 - change of possession
 - whether or not the pass or kick crossed the neutral zone
 - where there are multiple flags
 - whether a pass was caught or trapped
 - whether a pass was catchable on a pass interference call
 - whether a pass was forward or backward
13. **When in doubt about any aspect of what you have seen or heard, communicate with your colleagues to try to confirm your suspicions or to obtain additional information that will aid your judgement.**[@]

6.5 - Signals

- Your signals should be clear, distinct and deliberate at all times.
- If you are the Coverer, signal a timeout when the rules provide for stopping the clock or when a timeout is charged to a team or to the Referee.
- Repeat *all* timeout signals given by *any* other officials.
- The usual timeout signal is [S3]. However in the following circumstances, the Coverer should give the specified signal *instead* of the timeout signal:
 - when a touchdown, field goal or try is scored: [S5];
 - when a safety is scored: [S6];
 - when a touchback is awarded: [S7];
 - when a forward pass is incomplete, or a field goal attempt is wide or short of the goal, or when there is no score on a try: [S10].

These signals are sufficient to instruct the timekeeper or clock operator to stop the clock. Signal [S3] should be given *in addition* if a charged or injury timeout is awarded. However, signal [S3] should be given *alone* if the Coverer threw a flag for a foul by the scoring team.
- The on-field timekeeper should stop the clock before giving or repeating any timeout signal.^x
- During a running clock session (Rule 3-3-2), all officials should give stop and start the clock signals as normal. The on-field timekeeper should ignore a stop the clock signal unless it is for one of the reasons that does stop the clock during such a session. It does not matter if it takes a few extra seconds to establish that this is the case.**[§]
- Signals such as timeout or incomplete pass should be repeated two or three times (or held for a few seconds) to ensure that everyone sees them. More repetitions are excessive. Do not bend at the waist when giving incomplete pass signals - **height lends authority.**[§]
- On scrimmage plays, use the start the clock signal [S2] *only* when the ball becomes dead in bounds within 10 feet of the sideline and the line to gain has not been reached. As the Coverer, make the starting signal two or three times and no more. If the play ends beyond or close to the line to gain, give the timeout signal [S3] only.
- There is no need for the on-field timekeeper to echo the start the clock signal [S2]. If visual confirmation is required they may use signal [Sup12].
- When giving signals at the end of a play, continue to face the players in your area of responsibility until all threat of further action has passed. If you signal clearly enough (and continue the signal for long enough) your fellow crew members, the occupants of the press box and the spectators will all see the signal whatever direction it is given in.
- It is only the Referee's signals on penalties and unusual incidents that need to be given in the direction of the press box. Don't make signals *towards* the Referee while you still have players in your area who you need to watch.
- Unless you are absolutely certain that the Referee knows that the line to gain has been reached, that the play ended out of bounds, that there was a change of possession, or that there was a score, repeat the signal(s) you have given once you have established eye contact with the Referee, but only when there is no threat of further action in your area.
- Don't get excited when signalling (especially touchdowns). Be tranquil and poised. Don't become emotional. Maintain your equanimity. Get into the habit of making your signals unhurriedly, smoothly and calmly (except on pivotal plays that require a bit more emotion - see section 5.7).

14. If you are the Coverer, you will need to **give only one signal that the ball is dead.**^λ
 - (a) This will be using the dead-ball signal [S7] unless the start the clock signal [S2] (see 6.5.8 above), timeout signal [S3], touchdown/field-goal signal [S5], safety signal [S6] or incomplete pass/unsuccessful field-goal signal [S10] is appropriate instead.
 - (b) **Not giving a signal, or giving the wrong signal, will likely confuse other members of your crew, and possibly players, coaches and spectators as well. How will they know whether: a pass was complete or incomplete? the play ended inbounds or out of bounds? a first down has been achieved or not? the ball was in the end zone or not? a field goal attempt was good or not?**
15. Some common game scenarios and what signals need to be given relating to the game and play clocks:

Type of down	How game clock stops	How play clock starts	How game clock starts
Scrimmage down ends with a running game clock	Not applicable (clock keeps running)	Covering official signals S7 to start 40-second play clock	Not applicable (clock keeps running)
Scrimmage down ends with a stopped game clock (e.g. Team A first down or out of bounds before 2:00) and game clock will start on the Ready for Play	Covering official signals S3	40-second play clock starts on covering official's clock signal	Referee gives signal S2 when an official places the ball at the succeeding spot and is in position to officiate [®]
Scrimmage down ends with a stopped game clock (e.g. incomplete pass) and the game clock will start on the snap	Covering official signals S10	40-second play clock starts on covering official's incomplete pass signal	Starts on next snap
Down ends with a touchdown	Covering official signals S5	40-second play clock starts on covering official's touchdown signal	Not applicable (try down is normally untimed)
Free kick	Covering official signals S3	40-second play clock starts on covering official's clock signal	Starts on next snap
Clock stopped for injury/helmet off	Covering official signals S3	Play clock starts on the Referee's signal [S1]: 40 seconds if Team B responsible; 25 seconds otherwise	Referee gives signal S2

16. All scenarios above assume no foul is called. If there is a foul, once administration of the penalty has been completed, the play clock will be set to 25 seconds and the Referee will blow their whistle and give the ready-for-play signal [S1]. If the game clock should start on the ready, the Referee will then give signal S2 to start the game clock.
17. In a running clock session, unless there is a penalty or other game administration situation, the game clock will not stop. After game administration, the play clock will be set to 25 seconds and the Referee will blow their whistle and give the ready-for-play signal [S1] and then give signal S2 to start the game clock.
18. **Do not use any signal or action that is prohibited for persons subject to the rules, for example those specifically prohibited in Rule 9-2-1-a.**[@]

6.6 - Marking spots

1. There are only three ways to mark a dead-ball spot. These are:
 - (a) with a ball (placed so its axis is parallel to the sideline);
 - (b) with your foot;
 - (c) with a bean bag.
2. Place a ball at the spot if you have one and don't need to relay it, or mark the front tip of the ball with your downfield foot. **The Coverer must never move away from the spot except in the most exceptional of circumstances.** Then use a bean bag as a last resort.
3. Only use a ball to mark the *actual* dead-ball spot. Never place a ball on the ground at any other spot level with the dead-ball spot (except at the inbounds spot). Don't place a ball at the inbounds spot if the enforcement of a penalty has not been completed.
4. When marking forward progress with your foot do it inconspicuously. The best way is to stand with your feet level, with the instep of your downfield and upfield feet marking the front and back ends of the ball respectively. (In this context downfield means nearest the defensive team and upfield means nearest the offensive team.) If you want to extend your downfield foot slightly this is permissible, but don't draw undue attention to the position: there is nothing worse than two officials obviously indicating *different* spots.

Change codes: † better coverage; § fill gap; ° clarification; ® better communication; × deleted; ® rule change λ editorial

5. In normal play, forward progress usually only needs to be marked to a tolerance of one foot. Since the ball is just less than one foot long, this means there are only three positions that a ball can be in between any pair of yard lines:
 - (a) with the nose (most forward point) of the ball on **the back edge of**[◊] the forward yard line;
 - (b) with the middle of the ball midway between the two yard lines;
 - (c) with the tail (rearmost point) of the ball on **the front edge of**[◊] the back yard line.
 Note that in this system the ball is never positioned spanning a line.
6. Officials need only mark forward progress to the nearest one of these points, except:
 - (a) where the line to gain or goal line is concerned, in which case more accuracy is necessary;
 - (b) after a change of possession (start of new series), in which case the dead-ball spot should always be marked with the nose of the ball on the nearest yard line.
7. If you have difficulty judging the dead-ball spot when a ball carrier has begun a feet-first slide (Rule 4-1-3-r), subtract 2 yards from the spot where their body first touches the ground.
8. Officials may direct the spotting of the ball at the hash marks by giving the Spotter appropriate verbal instructions or signals, i.e.: "nose on" [Sup32], "middle" [Sup33] or "tail on" [Sup34].
9. If a series of downs started "middle", then the line to gain will be reached if the ball is at "middle" 10 yards on. Similarly for "nose on" and "tail on".
10. The lateral position of the ball is denoted by the following numbering system:
 - 1 hash on press box side
 - 2 goal post on press box side
 - 3 centre of field
 - 4 goal post opposite press box
 - 5 hash on side opposite press box

When using an elastic band or similar, one way to denote the position is to place the band on the 1st finger for left hash, 2nd finger for left goal post, 2nd & 3rd fingers if the ball is in the centre, 3rd finger for right goal post, and 4th finger for right hash. For finer resolution, other combinations of fingers can be used.

11. When marking a spot, continue to officiate. Don't stare at the ground – the spot won't move!

6.7 - Ball relay

1. After any play, the following roles need to be performed by the officials. In many cases, on a given play, one official will perform more than one role **and, in most normal situations,**[‡] it is highly unlikely that all members of the crew will be involved.
 - (a) **Coverer:** an official who is covering the dead-ball spot.
 - (b) **Retriever:** an official who procures a ball from a ball person, player or, occasionally, where it is lying on the ground.
 - (c) **Spotter:** an official who places the ball at the succeeding spot.
 - (d) **Relayer:** an official who acts as intermediary in getting the ball from the Coverer or Retriever to the Spotter.
 - (e) **Clearer:** an official who clears the old ball off the field
2. If you are the Coverer you should not normally handle a ball unless the ball becomes dead at your feet or you can easily procure a ball from a player without moving from your position, in which case you become the Retriever and you should relay it to the Spotter or a Relayer.
3. **By Rule 1-3-2-f, a replacement ball shall be obtained whenever the ball becomes dead outside the 9-yard marks. Aim to achieve this, but do not do so obsessively. If the ball person is slow or a colleague is out of position, and it is quicker to relay the previous ball to the succeeding spot, do so.**[§]
4. The Relayer should also be the Spotter if they can carry the ball to the succeeding spot before anyone else can get there.
5. Never be in a hurry to relay the ball. Accuracy is more important than speed. If you are not so good at throwing the ball accurately, you will need to make up for it by taking a few more steps to get closer to your target. **One of the worst things that can happen is to have the relayed ball on the ground (BOG), due to an inaccurate pass or poor catching. This looks bad and may significantly delay play.**[◊]
6. If you have a ball in your hand, move it into the field *towards* the succeeding spot rather than away from it (e.g. to the dead-ball spot).
 - (a) The exception to this is if there is a flag on the play, in which case the priority is to get the ball to the dead-ball spot.
 - (b) The exception to the exception is if there has been an incomplete pass - the ball still needs to go infield to the Spotter **at the previous spot.**[◊]
7. When a scrimmage play ends between or near the hash marks:
 - (a) The Umpire will **most frequently**[‡] be the Retriever and Spotter.
 - (b) On a long play, the Back Judge may act as the Retriever **unless they are the Coverer. In either case, if nobody else is nearer to the succeeding spot, they will also be the Spotter.**[§] Similarly, if there is a loss on the play the Referee or Centre Judge may act as the **Coverer, Retriever and Spotter.**[§]
 - (c) If a pass is incomplete deep down the middle of the field (**between the hash marks**),[◊] or the play ends in Team B's end zone, the Field Judge or Line Judge should act as Relayer and send their ball person to

retrieve the old ball. The Umpire will take the ball from the Relayer. The Relayer must ensure that *their* ball person is the one who retrieves the old ball.

8. When a scrimmage play ends well outside the hash marks:
 - (a) [IN xx0 FORMATION (CREW OF 4)] The wing official will almost always be the Coverer. The Referee and Umpire share the roles of Retriever and Spotter with whichever is nearer to the ball being the Retriever, and the other going to the inbounds spot to be the Spotter.
 - (b) [IN 2x1 FORMATION (CREW OF 5)]² Responsibilities will be similar to a crew of 4 except that on long gains the Back Judge may also be the Retriever or Spotter. The Referee,^x Umpire and Back Judge need to divide up their roles as follows: whoever is nearest the dead-ball spot is the Retriever; the next nearest is the Relayer or Spotter, and the furthest away may be the Spotter if they can get into position.
 - (c) [IN xx2/2x3 FORMATION (CREW OF 6D/7)] The Coverer will be either the wing official or the deep wing official on that side of the field. The Retriever will normally be the other sideline official on the same side. [IN 2x3 FORMATION (CREW OF 7)]² The Back Judge, plus either the Umpire or Referee (whichever is nearer) will act as Relayer(s). The Umpire or Referee should go to the inbounds spot to be the Spotter.
 - (d) [IN 3xx FORMATION (CREW OF 6C/8)] Responsibilities will be similar to a crew of 5/7 except that the **Umpire and Centre Judge will combine to perform the roles of Relayer and Spotter. The Referee should aim to not be involved in ball relay (except when a player hands a ball directly to them). Normally, if the Umpire is the Retriever or Relayer, the Centre Judge should move to the succeeding spot and act as the Spotter. Conversely, if the Centre Judge is the Retriever or Relayer, the Umpire should move to the succeeding spot and act as the Spotter.** † Efficiency is the key.
9. When the ball becomes dead in the end zone on a free kick, the Coverer will obtain a ball from either the returner or a ball person and either take it or relay it to the touchback spot.
10. In hurry-up situations (when the clock is still running), the Umpire (or Centre Judge, if there is one and especially if there is a loss on the play) *must* go and get the ball wherever it is inbounds, and act as both Retriever and Spotter. Other officials should not handle the ball, and must ensure that they are quickly in position for the next down (MOFO 6.2.10).

6.8 - Out of bounds coverage

1. When handling out-of-bounds plays, it is important that each official assumes a separate responsibility in order that duplication does not result in extra-curricular activity going unobserved.
2. If you are the first official (the Coverer):
 - (a) You should first of all signal timeout [S3] and, for your own safety, move to the out-of-bounds spot only after players have run through that area.
 - (b) You should signal timeout as soon as the ball becomes dead – don't wait until you reach the dead-ball spot. You may give the timeout signal while on the move.
 - (c) Remain on (or near) the sideline at the out-of-bounds spot to watch continuing action in or near the team area. It is essential to observe continuing action. If absolutely necessary, you can drop a bean bag and go further out to prevent/stop any continuing action.
 - (d) Once there is no further risk of fouls occurring, you may obtain a ball from either the ball carrier or a ball person and use it to mark the spot.
3. If you are the second official (the next official to reach the area: [IN xx2/xx3 FORMATION (CREW OF 6D/7/8)] this will be the other official on the same side of the field as the first official; [IN xx1 FORMATION (CREW OF 5/6C)] this will be the Back Judge, Referee or Centre Judge):
 - (a) You should go out of bounds with the ball carrier (going out as far as the ball carrier does) to specifically watch for and prevent fouls on them.
 - (b) If the ball carrier (or another player) goes into the opposition's team area, stay close to them and escort them back on to the field before you even start to think about ball relay.
 - (c) As Retriever, you should normally be the one to retrieve the old ball from the ball carrier or a new ball from the ball person and convey it to the Relayer for relay to the inbounds spot.
 - (d) If necessary you should loop around the Coverer (going further out of bounds in the process) in order to cover a ball carrier who carries on running beyond the Coverer.
4. If you are the third official (this will be [IN xx2 FORMATION (CREW OF 6D)] the Referee; [IN 3xx FORMATION (CREW OF 6C/8)] the Referee, Centre Judge or Back Judge; [IN 2x1/2x3 FORMATION (CREW OF 5/7)] the Referee or Back Judge) you should cover the action in the field of play behind the first two officials and act as Relayer.
5. If you are the fourth official (this will be [IN xx1/xx2 FORMATION (CREW OF 5/6)] the Umpire or Centre Judge; [IN 2x3 FORMATION (CREW OF 7)] the Umpire, Referee or Back Judge; [IN 3x3 FORMATION (CREW OF 8)] the Umpire, Centre Judge, Referee or Back Judge) you should observe continuing action between your position and the sideline and also move towards the sideline to assist as a potential Relayer.
6. [IN xx0 FORMATION (CREW OF 4)] The Referee and Umpire must co-ordinate as necessary to do the jobs of the second and third officials (Retriever and Relayer) described above. In particular, the Umpire must be prepared to move towards the sideline (or even out of bounds if necessary) to be in position to deter or observe continuing action. Either the Referee or the Umpire should act as Spotter, as appropriate.

6.9 - Dealing with fights

1. If by putting yourself between two players you can prevent a fight, then do so, but never do so at risk to your own safety (your number one concern). Never grasp a player's face mask to prevent or break up a fight.
2. If a fight breaks out on the field and you are the nearest official to a team area, you should regard it as your primary duty to keep substitutes and coaches from joining the argument. This will normally be the case if you are the wing or deep wing official on that side of the field, but on occasion you may be another official (e.g. the Referee or Back Judge) if, for example, the fight breaks out in an end zone.
3. If substitutes, coaches or other personnel come on to the field they should be immediately ordered off it. If they persist and cannot be recalled, record or note their numbers (or identities if not substitutes) so that they or their coaches may be cautioned once order has been restored (MOFO 3.5.7).
4. If you are nearest the fight, make a note of the numbers of the players involved, taking care to distinguish participants from those players trying to break up the fight. Those players definitely observed to have participated in the fight must be disqualified once order has been restored.

6.10 - Fumbles

1. Unless there has obviously been no change in team possession, if you cover a fumble recovery that is not advanced, signal to show which team has recovered the ball. If Team B has recovered the ball (or Team A has recovered after a multiple change of possession), signal timeout [S3] to stop the clock, then signal a first down [S8] in the appropriate direction. If Team A has recovered the ball, signal the number of the next down.
2. If no official has seen a player recover a fumble before a "scrum" forms on top of the ball, the ball should be awarded to the player in control of the ball once the scrum is unpled. If players from both teams have equal control of the ball, the ball should be awarded to the team last in possession (Rule 7-2-2-b). Touching the ball does not necessarily mean that a player is in control of the ball.
3. If it is necessary to "dig it out", and you are the nearest official, dig for the ball. If you are the next official, signal timeout [S3] to stop the clock, and this should be echoed by the rest of the crew. As the digging official, when you determine it, verbally relay the jersey colour of the player in possession^o to the nearest standing official, normally the Referee, who will then signal the proper direction. Only the Referee, if they are not the signalling official, may echo the direction signal. (See also Chapter 21 for bean bag mechanics on fumbles.)
4. A technique to encourage players to get off the pile is to shout out "they've got it", making it clear to players not in possession that they are too late to make a difference to possession.
5. Ensure that players from neither team contravene Rule 9-2-1-a-1-k by pushing or pulling opponents off the pile after the ball is dead.
6. Don't rush any decision. Before signalling a direction, take a moment to check that you have the direction right. That is why calling out a colour is a better practice than giving a team name or saying "offense" or "defense".^s

6.11 - Written records

1. All officials should record, in writing:
 - result of the toss
 - scores
 - charged team timeouts
 - sideline warnings
 - all fouls that you call
 - all disqualified players
 - all players penalised for unsportsmanlike conduct
2. [IN xx0/xx1 FORMATION (CREW OF 4/5/6C)] [LINE JUDGE]
[IN xx2/xx3 FORMATION (CREW OF 6D/7/8)] [FIELD JUDGE] must record all fouls called by all members of the crew.
3. The record of a foul should include: quarter, time, team, player, foul code, calling official(s) and whether the penalty is accepted, declined, offset, cancelled or waved off.[@]
4. At the end of the first and third periods, and before moving to the other end of the field, all officials should record the yard line of the ball and the down and distance. The Referee, Umpire and [IN 2xx FORMATION (NO C)] Line Judge or [IN 3xx FORMATION (CREW OF 6C/8)] Centre Judge should in addition record the lateral position of the ball. The Down Judge and Side Judge should also record the position of the chain clip.

6.12 - Timing responsibilities

1. Depending on the number of officials on the crew, the following officials are responsible for timings:

Responsibility	3	4	5	6C	6D	7	8
Game clock (on-field timekeeper)	L	L	L	L	L/F	L/F	L/F
Play clock	R	R	B	B	S	B	B
Duration of charged timeouts	R	U	U	U	U	U	U
Duration of interval between quarters	R	U	U	U	U	U	U
Duration of interval after score	R	U	U	U	U	U	U
Duration of interval between halves	L	L	L	L	L/F	L/F	L/F
Duration of game	L	L	L	L	L/F	L/F	L/F

2. Game clock operating options:
 - (a) [IN xx2/xx3 FORMATION (CREW OF 6D/7/8)] The crew shall decide whether the Line Judge or the Field Judge will be responsible for the game clock and associated duties. *As a rule of thumb, the Field Judge could be responsible if the clock is being operated off the field and the Line Judge if it is being operated on. Responsibility may also depend on the relative experience of the officials.*^o
 - (b) If the control device for a stadium clock is portable and can be used on/near the field of play, it is permitted for the on-field timekeeper to supervise an assistant to operate it from near the sideline. If the control device is watch-like, it is also permissible for the on-field timekeeper to operate the stadium clock as the official game clock. *In the latter case, there may be an increased risk of time not being kept accurately. This can be mitigated by having a second official keep backup time (e.g. if the Line Judge is the timekeeper, the Field Judge also keeps a clock as backup).*[§]
 - (c) [USING O2O/CREW RADIO] It is permitted for an assistant off the field to keep the game clock (Rule 3-2-4-a). This is an option that may improve accuracy of clock operation, but should only be taken when an additional official (experienced in timekeeping) is available and there is a vantage point where they have good visibility of the field. In the absence of a stadium clock, the assistant shall relay the time remaining to the crew by radio when required by rule, upon request, or at periodic intervals.
 - (d) The Video Judge must not be used as the clock operator/assistant due to their need to concentrate on other duties.
 - (e) If there is a visible game clock, it must be regarded as the official game clock. If not, it must be switched off. Don't split hairs about time on the clock. If the stadium clock says that a period has ended, don't overrule it unless you have good and strong grounds (MOFO 20.1).
3. The duration of the game is defined to be the time from the opening kickoff to the final whistle, including the half-time interval and time for any stoppages or suspensions.
4. [ON-FIELD TIMEKEEPER] Your primary responsibility is to the accuracy of the time by rule, and you may ignore incorrect clock stop/start signals given by the Referee or other officials if you have positive knowledge of the correct situation (**Exception:** the Referee has the final word on unfair clock tactics situations).[§]

6.13 - Counting responsibilities

1. Depending on the number of officials on the crew, the following officials are jointly responsible for counting players:

Responsibility	3	4	5	6C	6D	7	8
Team A on scrimmage downs	R,L	R,U	R,U	R,U/C	R,U	R,U	R,U/C
Team B on scrimmage downs	D,L	L,D	B,L,D	B,L,D	S,F	B,F,S	B,F,S
Team A on free kick downs	L,D	U,D	U,B,D	U,B,C	U,F,S	U,F,S,B	U,F,S,B,C
Team B on free kick downs	R,D	R,L	R,L	L,R,D	L,R,D	L,R,D	L,R,D

2. It is especially important to count players on field goals, punts, tries and after every change of possession.
3. Having *too many*² players on the field and not noticing it is one of the worst errors a crew can make.
4. The officials who have responsibility for counting the players on each team also have the responsibility for enforcing the restriction on the number of players allowed in the huddle.

6.14 - Alternate officials

1. Where alternate officials are assigned to a game, they may be used EITHER to perform specific mechanics OR to simply assist on the sidelines.
2. Pre-game duties of the alternate officials:
 - (a) Attend the pre-game conference.
 - (b) Pre-game on the field, assist with checking the chains, checking the balls, briefing the chain crew, briefing the ball boys, briefing the stadium clock operator(s), checking player equipment and any other task requested by the game crew.
 - (c) Introduce yourself to the Head Coach on the side of the field you will operate during the game. If there is no alternate official on the other side of the field, ask a sideline official on the other side to inform their Head Coach that there is an alternate official and your location.
3. Where specific mechanics are needed:
 - (a) As a ninth official, stand level with the line of scrimmage on the press box side of the field and discreetly assist the crew with rulings concerning balls and ball carriers crossing the neutral zone.
 - (b) As a tenth official, stay with the chain crew and note the down number, distance and yard line before each play.
4. Where no specific mechanic coverages are required, or in addition to the above, stand near the team area (at least one alternate official on each side of the field) and:
 - (a) assist the game officials in communicating with the Head Coach (and vice versa)
 - (b) observe any potential transgressions of the restricted area between the sideline and the coaching box, and work with the "Get-back coach" to encourage substitutes, coaches and others to remain in their proper areas
 - (c) observe potential transgressions of the mandatory and illegal equipment rules, and warn coaches where breaches may occur

- (d) observe the conduct of all persons in the team area and inform the game officials of any abuse or taunting emanating from there
 - (e) observe whether injured players leave the game and remain out of the game for at least one play
 - (f) confirm whether requests for timeouts come from the Head Coach
 - (g) liaise with television personnel where necessary
 - (h) be aware of the time to kickoff, and the progress of the half time interval
 - (i) observe play and assist the game officials in correcting any egregious errors, in particular:
 - (i) penalty enforcement spots and distances
 - (ii) timing errors
 - (iii) number of timeouts left for each team
 - (j) carry spare equipment (e.g. whistles, pens/pencils, flags, bean bags, radios)^o in case a member of the game crew loses theirs
 - (k) look out for your own safety at all times⁴
5. As an alternate official, wear full uniform, but cover your shirt with a non-stripy jacket or tabard to distinguish you² from the members of the main crew.
 6. The officials should decide in the pre-game conference which positions the alternates will slot into in the event that one, two or more of the crew is incapacitated. If the Referee is incapacitated, it is best that another member of the crew moves to Referee and the alternate replaces that official, unless the alternate official is an experienced Referee at the level of the game.

6.15 - Inadvertent whistles

1. If you do blow an inadvertent whistle, make sure that play stops. Blow your whistle repeatedly until all action ceases. Don't try to hide or cover-up the inadvertent whistle - we all make occasional mistakes and learn from them.
2. If you clearly hear a whistle blown on the field when the ball is or should be still alive, blow your own whistle to stop any further play. If in doubt, allow the play to continue. Don't respond to whistles from spectator areas or from nearby fields.
3. If you suspect that an inadvertent whistle was blown on the previous play, [USING O2O/CREW RADIO] ask who blew the whistle. Ascertain the facts of what actually happened. Decide whether inadvertent whistle provisions need to be applied. If so, apply inadvertent whistle provisions (Rule 4-1-2-b) and the philosophy laid down in MOFO 3.8.7. If not, continue the game. A referee's timeout will probably need to be taken while this is all determined.
4. [REFEREE][@]
 - (a) If there has been an inadvertent whistle, give the inadvertent whistle signal [S12] and announce, "There was an inadvertent whistle during the play".
 - (b) If the down is to be repeated, announce, "By rule, the down will be repeated".
 - (c) If the ball has been awarded in continuing action, announce, "The ball has been awarded to [name of team]" and what down it is.
 - (d) If the team in possession chooses to take the ball at the dead-ball spot, announce, "[Name of team] has chosen to take the ball at the dead-ball spot".
 - (e) If a penalty is accepted, announce, "By rule, the penalty will be enforced as if there was no inadvertent whistle". If a violation privilege is chosen, announce, "[Name of team] has chosen to take the ball [at the spot of illegal touching]", if appropriate.
 - (f) Continuing action recoveries do not normally require an announcement that there has been an inadvertent whistle, unless it was particularly obvious.

7. PRE-GAME CONFERENCE

A pre-game conference is an opportunity for the crew to get into the right frame of mind to officiate a football game. For this reason a pre-game conference should always be held.

Although the Referee normally conducts the pre-game conference, they must ensure that all members of the crew are actively involved in the discussion and that it does not turn into a monologue. When working with the same crew regularly, it is essential that the pre-game conference should be varied so that it does not become a boring ritual which everybody has heard before. Share the responsibility for the pre-game by assigning different members of the crew to talk about different points each game.

All aspects of the game must be covered during the pre-game conference; this includes both rules and mechanics. Discuss rare and unusual game situations and decide how you would cover them. Describe experiences of previous games and how you handled them.

The following checklist is provided as a guide.

7.1 - Pre-game duties

1. Coach's certification
2. Spot check players' equipment
3. Check and mark balls
4. Identify medical facilities
5. Instruction of chain crew and alternates
6. Instruction of ball persons
7. Instruction of commentator/stadium clock operator(s)
8. Inspection of field
9. Check radios
10. Liaise with Video Judge (if there is one)

7.2 - Coin toss procedure

1. First half procedure
2. Second half options

7.3 - Free kicks

1. Positions
2. Instructions to teams
3. Restraining lines
4. Count players
5. Starting clock
6. Momentum into end zone
7. Touchback
8. Untouched kick out of bounds
9. Blocking below waist
10. Kick-catch interference
11. Fair catch
12. Handing ball forward
13. Onside kick – illegal touching
14. Free kick after safety

7.4 - Scrimmage plays – general

1. Positions
2. Count players
3. Legality of offensive formation – wing officials signals
4. Man in motion
5. Legality of snap

7.5 - Scrimmage plays – runs

1. Coverage of ball carrier – in backfield, between tackles, sweeps, pitchout
2. Action in front of ball carrier
3. Clean-up coverage
4. Forward progress – out of bounds
5. Goal line/short yardage situations
6. Coverage of fumbles, and ensuing advances and returns

7.6 - Scrimmage plays – passes

1. Coverage of passer – roughing
2. Passer/pass behind/beyond line of scrimmage: clarify jurisdiction
3. Forward/backward pass/fumble: clarify jurisdiction
4. Intentional grounding: clarify jurisdiction
5. Ineligibles downfield
6. Keys and zones
7. Coverage of receivers
8. Complete/incomplete
9. Pass interference – offensive, defensive
10. First touching
11. Coverage on interception – momentum into end zone, blocking below waist

7.7 - Returns

1. Reverse mechanics
2. Boxing the play in
3. Goal line responsibilities

7.8 - Punts

1. Positions
2. Coverage of kicker – running into/roughing
3. Coverage of snapper
4. Blocked/touched on line of scrimmage – ball beyond/behind neutral zone
5. Kick-catch interference
6. Fair catch
7. Untouched in end zone
8. Out of bounds – marking spot
9. Illegal touching
10. Coverage of runback – ball carrier, other action, blocking below waist
11. Fakes

7.9 - Field goals & try attempts

1. Positions
2. Coverage of posts
3. Coverage of kicker/holder – running into/roughing
4. Coverage of snapper
5. Blocked/touched on line of scrimmage – ball beyond/behind neutral zone
6. Fakes
7. Coverage when defense gains possession

7.10 - General duties

1. Fumble pile-ups
2. Ball relay

7.11 - End of quarter duties

1. 1st & 3rd
2. Half
3. End of game
4. End of period ruling (if stadium clock(s))
5. Extra periods

7.12 - Timeouts

1. Records
2. Positions

7.13 - Measurements

1. Duties of each official

7.14 - Fouls & enforcement

1. Reporting – who, what, where, when
2. Recording fouls
3. Options
4. Signals
5. Enforcement

7.15 - Reserve positions in case of injury

1. If one official is hurt
2. If two officials are hurt

8. BEFORE THE KICKOFF

8.1 - Before the game – off the field

1. Meet with the other officials at the stadium at the agreed time. This should normally be at least 1½ hours before kickoff time for a regular game, and 2-3 hours for a playoff, international or other important game (unless the pre-game conference has been held in another place).
2. A pre-game conference is mandatory, either at the venue or at another time or place (including online) prior to the game. The Referee should ensure that sufficient time is allocated for a thorough pre-game conference. Anticipate any problems with changing rooms and allow extra time if multiple changing rooms may have to be used, since this may mean that the pre-game cannot happen while people are changing. Arrival times and the time to change should be planned and adjusted accordingly. [◊]
3. As early as possible after arriving at the stadium, inspect the facilities and the playing surface, particularly for hazards and obstructions. Seek the co-operation of game management to rectify any faults. The sooner game management is informed of a problem, the more time it has to fix it before kickoff. [§]
4. [REFEREE] Lead a thorough pre-game conference to prepare the crew mentally for the game. Ensure that all members of the crew contribute to it. A pre-game conference guide can be found in Chapter 7. [OTHERWISE] Participate in the pre-game conference. If the Referee is delayed or has to leave the conference for any reason, the conference should be led by [×] the senior official present.
5. [REFEREE] [UMPIRE] Prior to the game visit each team (normally in its changing room or on the field) at least one hour before kickoff.
 - (a) Identify and introduce yourself to the Head Coach.
 - (b) Verify that each Head Coach provides a roster and signs a Coach's Certification to confirm that all players have been issued with the mandatory equipment and have been instructed in its use, etc. Confirm the game kickoff time, and any other timing details concerning the teams' arrival on the field of play.
 - (c) Review with the Coach the items listed in section 4.3.
 - (d) Review any unusual game procedures or situations with the Coach. Note any trick plays that may be used.
 - (e) [UMPIRE] Spot-check players' equipment and taping. Record numbers of players with illegal equipment or without mandatory equipment so that they can be re-checked when they get out onto the field of play.
6. [OTHERWISE] While the Referee and Umpire are visiting the Head Coaches:
 - (a) If one or both teams are running drills on the field, you may choose to take advantage of this to get into position and (without whistles, flags or overt signals, and without making your presence too obvious) practice your keys, movement and response to the play.
 - (b) The officials responsible for briefing the chain crew and ball persons may go out onto the field and do this.
 - (c) Return to the changing room once you have completed your tasks or the teams have finished their drills.
7. [IN xx0 FORMATION (CREW OF 4)] [LINE JUDGE]
[IN xx1/xx3 FORMATION (CREW OF 5/6C/7/8)] [BACK JUDGE][§]
[IN xx2 FORMATION (CREW OF 6D)] [FIELD JUDGE][†] Examine the game balls provided. If they are acceptable, mark each ball. [×] Be responsible for ensuring that the game balls are conveyed to the field (seeking the assistance of other officials if necessary). ^λ
8. Complete any pre-game paperwork that is required by the competition or your officiating organisation.
9. [ON-FIELD TIMEKEEPER] Before leaving the changing room:
 - (a) Ensure that you have the correct time. Have a countdown stop-watch available and be conversant with its use. Check that another member of the crew is carrying a spare stop-watch in case the primary one becomes defective.
 - (b) Confirm the kickoff time and relay this to the other officials. It is your responsibility to ensure that all officials arrive on the field at the correct time.
 - (c) Ensure that the other officials also synchronise their watches with the correct time.
10. Check that you and all your colleagues are wearing the correct uniform and are carrying their necessary equipment. The Umpire normally leads on this.
11. Do the radio checks stipulated in section 25.2.
12. Leave the changing room with the other officials in time to arrive at the field 10-20 minutes before the scheduled start time (earlier if the chain crew and/or ball persons still need to be briefed, or the field is some distance away; later if not). Arriving at the field earlier is appropriate and necessary if you judge that there is a significant risk of misconduct there or if the crew wishes to conduct its preparations there. [×]

8.2 - Before the game – on the field

1. All officials should arrive at the field no later than 10 minutes before the scheduled kickoff time. Be earlier than this if you anticipate any difficulties with the teams, chains, chain crew, balls, ball persons, field markings or equipment, or are required to do so by the schedule for pre-game activities.
2. Note the location of the press box. If there is not a formal press box, the side deemed to be the press box is determined solely by the position of (in usual order of priority) the primary TV camera, the

announcer/commentator or the majority of spectators, *not* by which side of the field the home team chooses to use.

3. Note the location of the medical [personnel and](#)[§] facilities.
4. Check that game management has made any necessary changes to rectify faults in the facilities or playing area.
5. Summary of pre-game responsibilities:

Responsibility	3	4	5	6C	6D	7	8
Re-inspect field (primary)	R	R	B	B	S	B	B
Re-inspect field (secondary)			R	R	R	S	S
Spot check players' equipment (primary)	R	U	U	U	U	U	U
Spot check players' equipment (secondary)		R	R	C	R	R	C
Check teams and officials are ready on field	R	R	R	R	R	R	R
Check chain and brief chain crew	D	D	D	D	D	D	D
Ensure game balls are available	L	L	B	B	F	B	B
Brief ball persons (and alternate chain crew)	L	L	L	L	F/L	F/L	F/L
* Brief stadium game clock operator and announcer	L	L	L	L	L/F	L/F	L/F
* Brief stadium play clock operator	L	L	B	B	S	B	B
Meet with medical personnel	L	L	B	B	S	B	B

6. [REFEREE]

- (a) [IN xx0/xx1/2x2/3x1 FORMATION (CREW OF 4/5/6C/6D)] Assist the Back Judge or the Side Judge with re-inspecting the whole of the playing area and its immediate surrounds. [IN xx0 FORMATION (CREW OF 4)] You will need to do this inspection alone.
- (b) [IN 2xx FORMATION (NO C)] Assist the Umpire with spot-checking players' equipment.
- (c) Check that both teams are at the field and are ready for play.
- (d) If a competition mandates a minimum number of players and/or coaches must be present before kickoff, check this. There is no need to count heads if there are obviously more or less than the minimum number. If the minimum number is not reached, inform the Head Coach.

(e) [If an on-field play clock is being used \(and time permits\), brief the quarterbacks and scrimmage kickers on how they will be notified that the play clock has reached 10 seconds remaining. Do not interrupt any pregame preparation the players may be doing. If appropriate, speak to the coach running a drill and ask to speak to the players when the drill has finished.](#)[§]

- (f) Verify that all the other officials have completed their duties.

7. [UMPIRE] [CENTRE JUDGE] Spot-check player equipment. Get other officials to assist you once they have completed their own duties.

8. [DOWN JUDGE]

- (a) Locate and check the chain for length, kinks, and knots. You should carry tape or string against which to measure the chain (between the inside edges of the stakes).
- (b) Mark the mid-point of the chain (5 yards from each end) with a piece of tape or supplementary clip to help determine whether or not a defensive penalty will result in the line to gain being reached.
- (c) Introduce yourself to the chain crew and brief them in the procedures detailed in section 22.1.

9. [LINE JUDGE]

- (a) [IN xx0 FORMATION (CREW OF 4)]
 - (i) Ensure that the game balls are available.
 - (ii) Discuss with the available medical personnel what signals are to be used to summon them on to the field. Inform the other officials of the agreed signals.
 - (iii) If stadium play clocks are available, brief their operator
- (b) [\[IN xx0/xx1 FORMATION \(CREW OF 4/5/6C\)\]](#)[‡] OR [IF THE FIELD JUDGE IS THE ON-FIELD TIMEKEEPER]
 - (i) Introduce yourself to the ball persons and brief them in the procedures detailed in section 22.3. Retain possession of the balls until the ball persons are briefed – do not allow players to practice with them.
 - (ii) Organise and brief the alternate down box and line-to-gain marker crew (if provided) in the procedures detailed in section 22.2.
- (c) [ON-FIELD TIMEKEEPER]
 - (i) If a stadium clock is available, brief its operator
 - (ii) If there is an announcer, instruct them on signals and procedures, and inform them of the names and positions of the officials. Check and confirm with them details of the following:
 - (1) Kickoff time
 - (2) Pre-game ceremonies (anthems, announcing teams, etc.)
 - (3) Half-time activities (time to clear field)

10. [BACK JUDGE]

- (a) Ensure that the game balls are available.
- (b) If stadium play clocks are available, brief their operator
- (c) Discuss with the available medical personnel what signals are to be used to summon them on to the field. Inform the other officials of the agreed signals.

- (d) Re-inspect the whole of the playing area and its immediate surrounds. Note any unusual markings and notify other officials. Ensure that game management has rectified any faults.

(e) If time permits, brief the punt returners about fair catch signals. §

11. [FIELD JUDGE]

(a) [IN xx2 FORMATION (CREW OF 6D)] Ensure that the game balls are available. ◊

(b) [ON-FIELD TIMEKEEPER]

- (i) If a stadium clock is available, brief its operator
- (ii) If there is an announcer, instruct them on signals and procedures, and inform them of the names and positions of the officials. Check and confirm with them details of the following:
- (1) Kickoff time
 - (2) Pre-game ceremonies (anthems, announcing teams, etc.)
 - (3) Half-time activities (time to clear field)

(c) [NOT ON-FIELD TIMEKEEPER]

- (i) Introduce yourself to the ball persons and brief them in the procedures detailed in section 22.3. Retain possession of the balls until the ball persons are briefed – do not allow players to practice with them.
- (ii) Organise and brief the alternate down box and line-to-gain marker crew (if provided) in the procedures detailed in section 22.2.

(d) [IN xx2 FORMATION (CREW OF 6D)] If time permits, brief the punt returners about fair catch signals. §

12. [SIDE JUDGE]

(a) [IN xx2 FORMATION (CREW OF 6D)]

- (i) × If stadium play clocks are available, brief their operator.
- (ii) Discuss with the available medical personnel what signals are to be used to summon them on to the field. Inform the other officials of the agreed signals.

(b) Re-inspect the whole of the playing area and its immediate surrounds. Note any unusual markings and notify other officials. Ensure that game management has rectified any faults.

13. [DOWN JUDGE AND LINE JUDGE][‡] Ask the Head Coach to appoint or identify a "get-back coach" to assist you in keeping personnel well clear of the sideline during the game.

14. [DOWN JUDGE, LINE JUDGE, FIELD JUDGE AND SIDE JUDGE][‡]

(a) Ensure that yardage markers and other sideline equipment are out of your way, particularly close to the goal lines and end lines.

(b) [‡] If you have not already done so, identify and introduce yourself to the captains and coaches of the team on your side of the field.

15. [ALL OFFICIALS] [USING O2O/CREW RADIO] When you have completed your duties, notify your colleagues of this. §

8.3 - Ceremonies

1. There are a number of different formats for ceremonies prior to kickoff. This section attempts to address the officials' roles and responsibilities at these times. Game management may vary the procedure, but equally may seek the officials' advice in how to organise the ceremony.
2. At a tournament or when a series of games is being played at the same venue, try to achieve consistency about the way the ceremonies at each game are conducted.
3. Ceremonies are often used for one or more of the following purposes:
 - (a) to introduce the teams
 - (b) to play the national anthem(s)
 - (c) to observe a minute's silence in respect of someone who has died or to commemorate a national day of mourning or remembrance
 - (d) to involve some notable[‡] person (e.g. politician or celebrity)

The coin toss may take place before, after or during these, provided that Rule 3-1-1 is not infringed.
4. Principles to aim to achieve:
 - (a) If national flags are on formal display (i.e. not just being waved by spectators), it is a good idea to face them during the playing of the national anthem(s).
 - (b) You should very much avoid having either or both teams behind you or out of your sight. Try to adopt a position or angle where you can see both teams at all times during the ceremony.
 - (i) It is preferable that both teams remain in their team area during the ceremony, but game management may wish to have both teams on the field.
 - (ii) If both teams are on/near their sideline facing the middle of the field, be near the centre of the 20-yard line at one end of the field, facing the opposite end line, so that both team areas are in your view. If national flags are on formal display at one end of the field, use the end that enables you to face them. Otherwise, use the end that places you to the right of the press box.
 - (iii) If both teams are lined up together, face the same way as them, with you between them and keeping sight of them at least in your peripheral vision.
 - (iv) Do not be so far away from the players that you cannot easily intervene (e.g. verbally) if they behave inappropriately.

- (c) The officials should line up in single file abreast. The Referee should be in the centre of the line.
- (d) If the principles above are adhered to, the officials' positions on the 20-yard line are shown in the following diagram:[§]

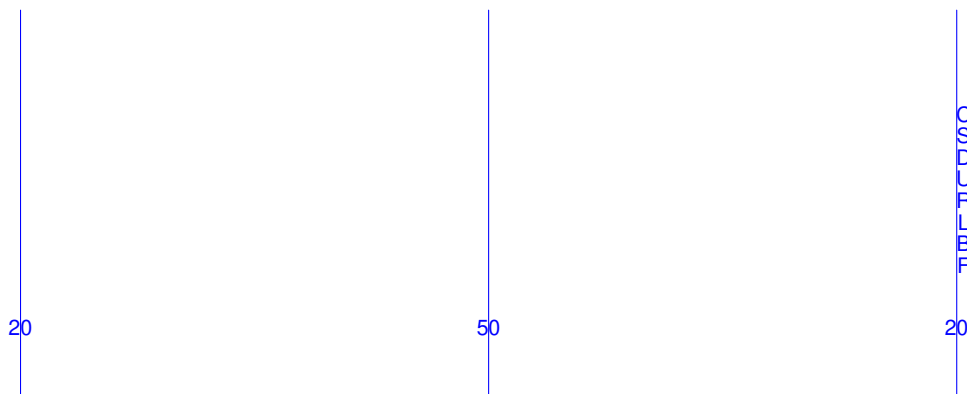

or at midfield in this diagram:

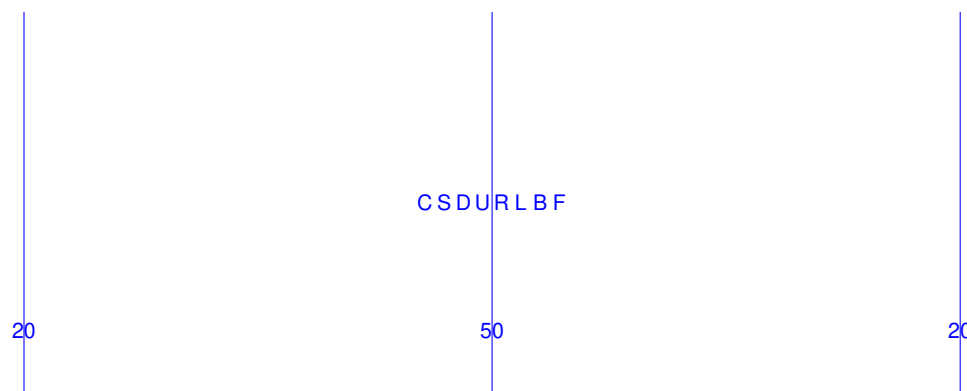

- (e) All officials must remove their cap during the playing of any national anthem or holding a minute's silence. It is a matter of personal taste whether an individual official holds it over their chest, lower down, or at their side.
- (f) If there is no master-of-ceremonies and/or game management ask the Referee to start the anthem(s) or minute's silence, the Referee will signal the start by taking off their cap. Under these circumstances, the Referee should time the duration of the silence, and signal the end of it by replacing their cap on their head.
- (g) If the ceremony is entirely under the control of the officials, it is best to do the coin toss first, then play the anthem(s) or have the minute's silence once the captains have returned to their teams on the sideline. In this case the officials should line up as in (b.ii) and (d.i)[§] above.
- (h) If both a minute's silence and national anthem(s) take place, the protocol is for the minute's silence to take place before the playing of any anthem. This ensures that the ceremony ends on a "happy" note rather than a "sad" one.

8.4 - Coin toss

1. After completion of pre-game duties, the Referee, Line Judge, Back Judge and Field Judge go to the press box sideline and the Centre Judge, Umpire, [Down Judge](#) and Side Judge go to the opposite sideline.
2. Get the team captains of the team on your side of the field and have them ready on the sideline 5 minutes before scheduled kickoff time.
 - (a) Ensure that there are no more than four captains (excluding non-playing mascots) and that they are carrying rather than wearing their helmets.
 - (b) The captains should be lined up on the sideline. On the press box sideline, they should be lined up on the left shoulder of the Referee or Field Judge. On the sideline opposite the press box, they should be lined up on the right shoulder of the Umpire or Side Judge.

3. Positions and duties during coin toss ceremony:

- (a) [IN xx0/xx1 FORMATION (CREW OF 4/5/6C)] On the Referee's signal, the Referee and Umpire shall escort their respective captains to the centre of the field **at normal walking pace[§]** (see diagram below). The Umpire will introduce their captains to the Referee and then step back to a position where they can witness the toss.

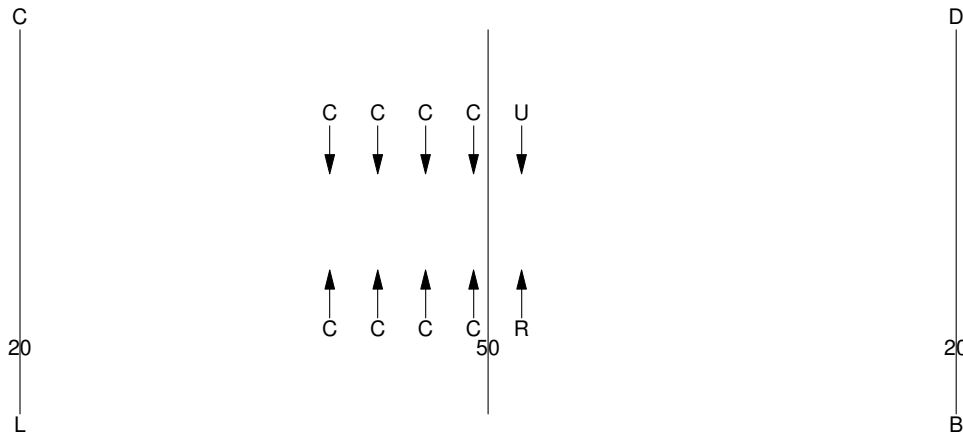

- (b) [IN xx2/xx3 FORMATION (CREW OF 6D/7/8)] The Referee and Umpire shall take up position in the centre of the field. The Field Judge and Side Judge shall escort their respective captains on to the field **at normal walking pace[§]** and introduce them to the Referee (see diagram below). Once they have done this, they should **turn round and walk back[◊]** to the sideline.

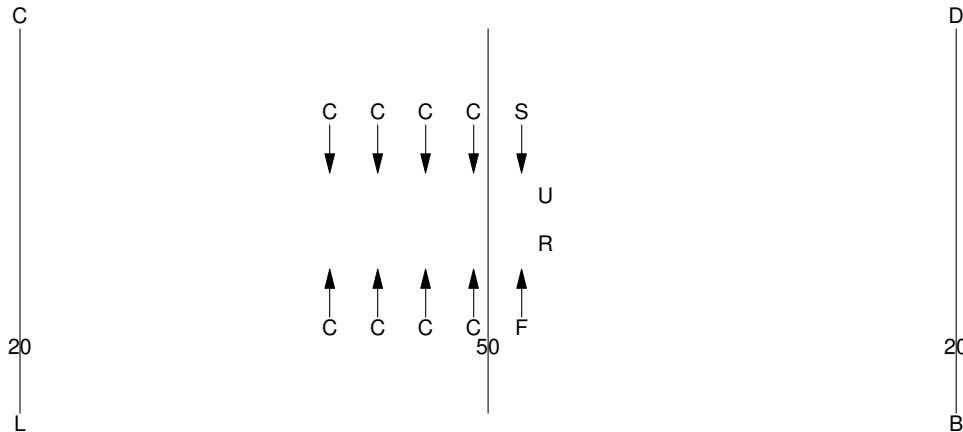

- (c) The remaining officials should monitor the players in the team area on their side of the field.
- At least one official should be positioned on or near each 20-yard line in order to be able to monitor the entire team.
 - If one or more of the remaining officials is still carrying out their pre-game duties (such as briefing the chain crew), that takes precedence over this ceremonial duty.

- (iii) One official will be holding the ball for the kickoff. [IN xx1/xx3 FORMATION (CREW OF 5/6C/7/8)] This is the Back Judge. [IN xx0 FORMATION (CREW OF 4)] This is the Line Judge. [IN xx2 FORMATION (CREW OF 6D)] This is the Field Judge. [◊]

- (d) During the toss ceremony, only those participating in the ceremony should be on the field. All other players, coaches, etc. should be in the team area (Rule 3-1-1). The officials not involved in the toss ceremony should enforce this (unobtrusively whenever possible).

4. It is not necessary for the Referee to introduce the officials to the captains, nor for any of the officials to shake hands with any of the captains.
5. [REFEREE] Ask the captains to introduce themselves to each other. Have the home team stay still and have the visiting team walk around and shake hands with them (see diagram below).

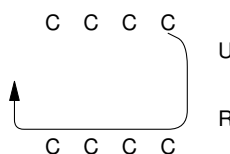

6. [REFEREE]

- (a) [USING PUBLIC RADIO] Turn the radio on and leave it on until you have announced and signalled the result of the toss. If something goes wrong, turn it off temporarily while you resolve the problem, but if at all possible turn it back on once you are able to proceed.
- (b) Show the speaking captains both sides of the coin, and clarify any doubt there may be as to which side is heads and which side is tails.

- (c) Ask the visiting captain to call the toss clearly (ask them again if their call is not clear).
 - (d) Announce clearly the captain's call.
 - (e) Toss the coin and either catch it or let it drop to the ground in view of the captains.
 - (f) Indicate the winning captain by placing a hand on or near their shoulder.
 - (g) Ask the winning captain for their chosen option.
7. [UMPIRE]
- (a) Witness all the significant parts of the coin toss ceremony, including the visiting captain's call and both captains' options.
 - (b) Ask the Referee to clarify or correct any part that you think has not been communicated clearly and correctly.
 - (c) Record who won the toss and both teams' choice of options immediately. §
8. The winning captain can choose to:
- (a) defer their options to the second half;
 - (b) receive the ball or kick off;[‡]
 - (c) defend either goal.
- If the captain's option is unusual (e.g. choosing to kick off or choosing an end),[‡] confirm that you heard their choice correctly.
9. If the winning captain elects to defer their options to the second half, the Referee should, after placing a hand on or near the captain's shoulder, step well clear and give the option deferred signal [S10] towards the press box. The losing captain should then be given the remaining options.
10. [REFEREE]
- (a) Instruct the captains to face each other with their backs to the goal that they will be defending.
 - (b) Step back to be in front of the captains of the team that had the options for the first half, ensuring that your position is not obscured from the press box.
 - (c) Signal the choice by making a kicking [S30] or catching motion [Sup13] while facing the same direction as the captains. There is no need to give the opposite signal for the other team.
 - (d) If the captain elects to defend a goal, point with both arms towards the goal line and then give an appropriate signal for the choice of the other captain.
11. At the request of game management, the toss of the coin may be performed by a VIP or attended by a small group of people. The following represents best practice when this is the case.
- (a) Prior to the coin toss ceremony, the VIP should be located a few feet out of bounds on the press box side of the field, near the midfield line.
 - (b) [IN xx0/xx1 FORMATION (CREW OF 4/5/6C)] Have them accompany the Referee to the field (usually on their right shoulder). [IN xx2/xx3 FORMATION (CREW OF 6D/7/8)] Have them join the Referee and Umpire in the centre of the field.
 - (c) For the duration of the coin toss ceremony, the VIP should stand between the Referee and Umpire.
 - (d) [REFEREE] If the VIP has not been introduced by the public address announcer, try to introduce them yourself (e.g. "Here to toss the coin is the Honourable Archibald Zebra, Mayor of Frumfrum").
 - (e) [REFEREE] Get the captain's choice of heads or tails before asking the VIP to toss the coin. If you have the coin, do not give it to the VIP until you are ready for them to toss it. Ask them to toss it a few feet (about a metre, if they are more familiar with metric units)[@] into the air and aim it to come down between the speaking captains.
 - (f) [UMPIRE] Once the captains' options have been determined and the Referee is announcing them, gently remind the VIP to leave the field (normally to the press box sideline).
12. **Summary:**
- (a) indicate the team that has won the toss, and if they have deferred their options;
 - (b) determine who is going to receive, and at which end;
 - (c) move the captains (this tells everyone which goal each team is defending);
 - (d) indicate *either* who is receiving *or* who is kicking off, but *not* both;
 - (e) it is not necessary for spectators to be told which option each captain has chosen other than in the case of a deferral.
13. Unless there is a national anthem/minute's silence ceremony, go directly to your kickoff position[‡] after the coin toss ceremony has been completed.
14. [ALL OFFICIALS] Record who won the toss and both teams' choice of options. [USING O2O/CREW RADIO] [REFEREE OR UMPIRE] notify colleagues while the captains are returning to their sidelines. §
15. Before going to your position,
 [IN xx0 FORMATION (CREW OF 4)] [LINE JUDGE]
 [IN xx1/xx3 FORMATION (CREW OF 5/6C/7/8)] [BACK JUDGE]
 [IN xx2 FORMATION (CREW OF 6D)] [FIELD JUDGE][‡] bring the ball for the kickoff on to the field and pass it to the Umpire.

9. REFEREE AND CENTRE JUDGE

9.1 - Free kicks

9.1.a – Priorities

Prior to the kick:

1. [REFEREE] Determining whether, based on the state of the game, an onside kick is likely. (An onside kick is likely if the team kicking off is behind in the score late in the game.) If it is, instructing the crew to switch to onside-kick positions by [USING O2O/CREW RADIO] or discreetly pointing first to the official who needs to shift their position and then to the spot they should move to.
2. [REFEREE] Counting Team B players and signalling the count [one of Sup3, Sup4 or Sup24] to colleagues. Noting count signals from colleagues. Recounting if your count differs from that of colleagues.
3. [CENTRE JUDGE] Counting Team A players and signalling the count [one of Sup3, Sup4 or Sup24] to colleagues. Noting count signals from colleagues. Recounting if your count differs from that of colleagues.
4. Reminding the players to count their number if the team you are responsible for counting does not have precisely **the correct number of[‡]** players on the field.
5. Checking readiness for play:
 - (a) Checking side and end zone areas to ensure that all non-players are out of the restricted areas, that non-participants are off the field of play, **that the safety zone is clear,[®]** and that all team personnel are within the team area.
 - (b) Ensuring that the chain crew (and the alternate down box and line-to-gain marker operators, where provided) have moved themselves and their equipment well out of the way and that the equipment has been placed on the ground outside the team areas and **outside the safety zone[®]** at the receiving team's end of the field. Checking that the ball persons are in position.
 - (c) [CENTRE JUDGE] Ensuring that all Team A players **have been within the nine-yard marks after the ready for play and prior to the kick,[‡]** (Rule 6-1-2-c-5) and that nobody other than the kicker is more than five yards behind the ball.
 - (d) [REFEREE] Checking that the kicking team has at least **the minimum number of** players on either side of the kicker.
 - (e) [REFEREE] [IN F4 FORMATION (CREW OF 4)] Monitoring the 25-second clock and penalising the kicking team if it runs out.
 - (f) [REFEREE] Checking that all officials are ready and facing the field of play.

During the kick play:

6. Observing whether a free kick goes out of bounds nearest to you without being touched by the receiving team. Ruling whether a Team B player near the sideline touches the ball while out of bounds.
7. Watching players for a fair catch signal, and being prepared to rule on any interference with the opportunity to catch the kick.
8. Giving the start the clock signal [S2] only if the ball is first legally touched in the field of play **and you are the nearest official or you have the best view of it.**
9. [REFEREE] Ruling whether the ball becomes dead in the end zone or not.
10. [REFEREE] [IN F4-5 FORMATION (CREW OF 4/5)][‡] Marking the forward progress or out of bounds spot if the ball becomes dead on your side of the field. This responsibility extends up to Team A's 2-yard line.
11. Marking the spot with a bean bag of any backward pass, handing or fumble in your area.
12. [CENTRE JUDGE] **Marking the dead-ball spot if you are the nearest official when the ball carrier is tackled or goes out of bounds.**
13. [CENTRE JUDGE] **Ruling a touchdown at Team A's goal line.**
14. Observing fouls/violations by all players generally in your area, but particularly:
 - (a) illegal blocks in the back and holding fouls at the point of attack
 - (b) illegal blocks below the waist
 - (c) contacting an opponent with the crown of the helmet or targeting a defenseless opponent above the shoulders
 - (d) safety-related fouls such as face mask, tripping, chop blocks, illegal wedges or illegal blind-side blocks
 - (e) late hits by any player after the ball is dead
 - (f) any player of the kicking team who enters the field of play after the kick or who voluntarily goes out of bounds during the kick and returns inbounds
 - (g) **illegal forward handing or illegal forward passes**

9.1.b – Initial positioning

Normal kicks:

1. [REFEREE]
 - (a) [IN F6-8 FORMATION (CREW OF 6/7/8)] Be in position A (see 26.1) on Team B's goal line near the centre of the field, staying clear of any players in the vicinity. If you expect the kick to go deep into the end zone, adopt a deeper initial position.

- (b) [IN F4-5 FORMATION (CREW OF 4/5)] Be in position C (see 26.1) [slightly behind](#)[◊] Team B's goal line outside the sideline opposite the press box side of the field. Stand where you can see in a straight line over the pylon towards where the kick will come from.

2. [CENTRE JUDGE]

- (a) [IN F8 FORMATION (CREW OF 8)] Be in position G (see 26.1) on Team A's restraining line outside the sideline opposite the press box side of the field.
- (b) [IN F6 FORMATION (CREW OF 6)] Be in position E (see 26.1) outside the sideline opposite the press box on Team B's restraining line.

Onside-kicks:

3. [REFEREE]

- (a) [IN F4-5 FORMATION (CREW OF 4/5)] Move to position A (see 26.1) near the centre of the field on Team B's goal line or deeper than the deepest returner.
- (b) [IN F6/F8 FORMATION (CREW OF 6/8)] Remain in the normal position.
- (c) [IN F7 FORMATION (CREW OF 7)] Move to position C (see 26.1) on Team B's goal line outside the sideline opposite the press box side of the field.

4. [CENTRE JUDGE]

- (a) [IN F8 FORMATION (CREW OF 8)] Remain in the normal position.
- (b) [IN F6 FORMATION (CREW OF 6)] Move to position G (see 26.1) outside the sideline opposite the press box on Team A's restraining line [as the Down Judge moves into your normal position.](#)[◊]

Free kicks after a penalty or safety:

5. When a free kick is taken following a penalty or a safety, the same relative positions should be taken, moving up or down the field as appropriate.

9.1.c – Response to what happens (movement and signals)

Prior to the kick:

1. [REFEREE]

- (a) Remind colleagues on Team B's goal line to get into position and get ready if they have not already done so.
- (b) When all players are in position and ready for play, check that all officials on Team B's goal line are ready and that the Umpire has their arm in the air.
- (c) Give the ready for play signal [S1] and sound your whistle for the start of play.

2. If anything happens that should prevent the kick taking place (e.g. a non-player enters or approaches the field of play), [toot your whistle](#), give the timeout signal [S3] and deal with the problem.

During any kick play:

3. If you see any player of the kicking team voluntarily go out of bounds during the kick, drop your bean bag or hat to mark their exit, and your flag if they return.
4. If the clock should start when the ball is first legally touched in the field of play, give the start the clock signal [S2] if you are the nearest official or the one with the best view.

During a kick play that goes deep:

5. After the ball is kicked, observe the players in your area of responsibility (see 26.1). After checking its initial trajectory, do not watch the flight of the ball.

6. [REFEREE]

- (a) [IN F4-5 FORMATION (CREW OF 4/5)] If the kick threatens to go into the end zone, [step up to the goal line extended](#)[◊] (out of the way of all players) to rule on a touchback. If the ball threatens the pylon, be there to be able to rule on whether the ball goes out of bounds in the field of play or the end zone.
- (b) If the live ball and at least one player go deep into the end zone, move to cover the end line.
- (c) If a touchback occurs:
- (i) Sound your whistle loudly to prevent further action.
 - (ii) Move infield ahead of any receiver who has the ball. Until you get in front of them, continue to watch them in case they are fouled.
 - (iii) Give the touchback signal [S7].
- (d) On a deep kickoff, follow the ball carrier and keep them [boxed in](#)² between you and the upfield officials.

7. [CENTRE JUDGE]

- (a) [IN F6 FORMATION (CREW OF 6)] Move downfield along the sideline while the kick is in the air. During the return, stay ahead of the ball carrier, keeping them [boxed in](#)² between you and the downfield official. On a long run, be at Team A's goal line before the ball carrier. [You have shared responsibility for the goal line.](#)[◊] Mark the dead-ball spot if you are the nearest official when the ball carrier is tackled or is out of bounds.
- (b) [IN F8 FORMATION (CREW OF 8)] Angle slowly infield as you move down the field. Observe action ahead of the ball carrier. Keep all players in front of you and maintain a safe cushion between you and the return, while not being too far away to get your flag to the spot of a foul you observe. On a long run, stay ahead of the players and get to the goal line ahead of the ball carrier. [You have shared responsibility for the goal line.](#)[§] You [also have](#)² responsibility for the end line should that be threatened (e.g. after a fumble near Team A's goal line). When you are sharing responsibility for a line (or pair of lines) with other officials, adjust so that you get a complementary view of the play.

8. [IF ON A SIDELINE] If the ball goes out of bounds in your area, go to and hold the spot, dropping your flag if appropriate.

During a kick play where the kick is short:

9. [REFEREE] Stay deep so that you get a long view of the action. You may be the only official who observes:
- that Team A did not have at least **the minimum number of**[◊] players on each side of the kicker at the kick
 - a fair catch signal
 - kick-catch interference
 - unnecessary roughness or a late hit
10. [CENTRE JUDGE]
- Maintain a position where you can see the ball and the blocks by Team A players.
 - [IF ON TEAM A'S RESTRAINING LINE] Particularly **observe**² the blocks made by Team A players before they are eligible to touch the ball (Rule 6-1-12).
 - [IF ON TEAM B'S RESTRAINING LINE] Know where and by whom the ball was first touched. Mark any spot of illegal touching with your bean bag (Rule 6-1-3).
 - If you are the nearest official when the ball becomes dead, signal timeout [S3] and mark the dead-ball spot.

9.1.d – Advanced techniques

1. [REFEREE] You may adjust your position according to such factors as the free kick spot, the wind and the known strength of the kicker's foot. However, it is important to be on the goal line (and particularly, at the pylon) before the ball gets there in crucial situations. **If the ball threatens the pylon, be in line with the kick so that you can rule whether the ball crosses the goal line or the sideline first.**[§]
2. [CENTRE JUDGE]
- [IN F6 FORMATION (CREW OF 6)] Pay particular attention to the blocks made by the two players from Team B's front line who were nearest you at the kick.
 - [IN F8 FORMATION (CREW OF 8)] Pay particular attention to the blocks made by the middle player(s) from Team B's front line.
 - If an expected outside kick is instead kicked deep, move into the field of play. You, the Umpire and the other official on Team A's restraining line each take responsibility for one third of the middle of the field (Figures 26.1.G and 26.1.J). Leave sideline responsibility in your area to the Side Judge or **Down Judge**.
3. **After the ball is dead and all action is ceased, if you are the nearest official to the previous spot make sure that any kicking tee has been removed from the field.**[◊]

9.2 - Basic scrimmage plays

9.2.a – Priorities

- Knowing the down and distance, and signalling the down to your colleagues. Noting the down signals given by colleagues. Checking that the down box displays the correct number. Not allowing play to start if there is a dispute about the down number.
- Counting Team A players and signalling the count [one of Sup3, Sup4 or Sup24] to your colleagues. Noting count signals from colleagues. Recounting if your count differs from that of colleagues.
- Observing false starts in general and, in particular, by backs and the quarterback. **This includes when Team A never sets.**
- Observing other illegal shifts (no 1-second pause after simultaneous movement by Team A players).**[◊]
- [REFEREE] Warning Team A verbally ("10 seconds" or "hurry") when there are 10 seconds left on the play clock, and [IN xx0 FORMATION (CREW OF 4)] penalising them if the play clock runs out.
- Observing the legality of the snap.
- If there is a pre-snap foul, stopping all action by tooting on your whistle and giving the timeout signal [S3].
- Anticipating whether the play is a run or a pass by reading the initial action of the interior linemen. If they move backwards it is likely that a pass play will develop. If they charge forwards or pull, it is likely that a running play will develop.
- Being aware of where the line to gain is in relation to the line of scrimmage so that you don't have to look at the chain to know if the dead-ball spot is close to the line to gain.
- Being aware of the boundaries of the tackle box.
- Observing substitution infractions by Team A, For example:
 - replaced players not leaving the huddle within 3 seconds of an incoming substitute entering it
 - breaking the huddle with **too many**² players
 - keeping **too many**² players in the huddle/formation for more than three seconds
 - substitutes coming on to the field, communicating, and then leaving the field
- Noting any ineligible receivers in the backfield between the tackles, because of the potential for illegal touching and ineligible receiver downfield fouls.
- Observing the legality of the formation, in particular the requirement for **a minimum number of**² players numbered 50-79.

14. Managing the substitution process if Team A makes a substitution while the snapper is at, near or moving towards their position at the line of scrimmage. [§]

9.2.b – Initial positioning

1. Be where you can see the ball at the snap.
2. Normal scrimmage down position is 5-7 yards behind the deepest offensive back (or 13-15 yards behind the line of scrimmage), normally **behind the normal position of the tackle or tight end on that side. This should place you 5-10 yards wide of the snapper. This position gives you the best chance of judging the extent of the tackle box.** [†]

Side of the formation:

3. [REFEREE]
 - (a) [IN 2xx FORMATION (NO C)] Be on the throwing arm side of the quarterback so that you are more likely to be able to see their arm when they start their passing motion.
 - (b) [IN 3xx FORMATION (CREW OF 6C/8)] Be on the right-hand side of the quarterback. [†]
4. [CENTRE JUDGE] Be on the **left-hand side of the quarterback opposite to the Referee. You are more likely to be able to see a left-handed quarterback's arm when they start their passing motion.** ^{†×}

9.2.c – Response to what happens (movement and signals)

1. If Team A players adjust their position, ensure you can still see the ball at the snap.
2. Keep out of the way of players shifting or in motion.

9.2.d – Advanced techniques

Reasons for varying (or not) your initial position:

1. Generally, the higher the standard of play and the faster the players, the deeper and wider you need to stand. ^x
2. Be deeper and wider if your mobility is hindered either by your condition or ground conditions (e.g. mud or uneven surface).
3. There is no need to coordinate your position to the position of the Umpire.

Signalling the player count:

4. The latest time to make the player count signal is when the offensive team breaks its huddle (but it can and should be done earlier if possible). [IN 3xx FORMATION (CREW OF 6C/8)] [CENTRE JUDGE] You do not need to count and signal if you don't have time to do so because you have spotted the ball.

9.3 - Running plays

9.3.a – Priorities

1. Observing the ball carrier and action around them until the ball crosses the neutral zone.
2. Observing any fumble where you are the nearest official or have the best view, and marking the spot with a bean bag.
3. Being prepared to help with, or make, a ruling on whether a pass is backward or forward, and signalling a backward pass [Sup5] immediately if the pass is clearly backward. Normally leave the direction of a quick pass to the wing officials. Noting any backward pass signal from the wing officials.
4. [IN xx0/xx1 FORMATION (CREW OF 4/5/6C)] Marking the dead-ball spot (with the possible assistance of the wing officials) if the quarterback is tackled or goes out of bounds behind the neutral zone.
5. Observing fouls by all players generally in your area, but particularly:
 - (a) illegal block in the back and holding fouls around and slightly in front of the point of attack, especially those made by a back, or the tackle or guard on the same side of the formation as you
 - (b) safety-related fouls such as face mask, tripping, illegal blocks below the waist, chop blocks or illegal blind-side blocks
 - (c) late hits by any player after the ball is dead
 - (d) unnecessary roughness against the quarterback after they have handed off the ball

9.3.b – Response to what happens (movement and signals)

1. If the action comes towards you, backpedal to keep clear, but keep the players in view at all times. Don't turn your back on the play.
2. If the play goes up the middle, follow safely behind while observing players making lead blocks and those behind the play who may be in danger.
3. If the play goes to one side or the other, move laterally to be able to observe critical blocks for legality. [IN 3xx FORMATION (CREW OF 6C/8)] If the play comes to your side, watch lead blocks. If the play goes to the other side, watch action behind and inside the play.
4. Normally, at the end of the play, close in on the action to deter dead-ball fouls. This is particularly the case on short runs into a side zone or out of bounds where you may be the second nearest official. However, on long runs, hang back so as to observe players who have been left behind by the play for unnecessary roughness.

9.3.c – Advanced techniques

1. Don't blow your whistle when the ball carrier's back is toward you or you are obscured by other players or officials² – they may have fumbled the ball without you seeing it. See leather! Be certain that the ball is dead.
2. If a pile-up of players forms, give the timeout signal [S3], converge on the pile, determine who has possession (MOFO 6.10) and encourage players to unpile safely.
3. If you're not the nearest official to the dead-ball spot, observe for late hits and other illegal acts. It is particularly your responsibility to observe action close to the wing officials as they are concentrating on the forward progress spot.

Particular types of running play:

4. Quick handoffs that result in short yardage gains will be the responsibility of the Umpire or wing officials while you concentrate on action behind the ball.
5. On plays into the line, if the ball carrier is driven back after their forward progress is stopped, retrieve the ball from the ball carrier and relay it to the Spotter.
6. On pitchout option plays:
 - (a) If the quarterback keeps the ball, there is no need for you to cover them beyond the neutral zone. When they turn up field, switch to observing threats of fouls against the trailing back.
 - (b) If the quarterback pitches the ball, continue to observe them while there is a threat that they may be fouled.

9.4 - Pass plays

9.4.a – Priorities

1. Ruling whether the passer has passed or fumbled the ball. If it is a fumble, marking the spot with a bean bag. [IN 3xx FORMATION (CREW OF 6C/8)] Taking your time to ensure that you and your colleague do not make contradictory calls.
2. Ruling (with help on a quick pass from the wing officials) whether a pass is backward or forward, and signalling a backward pass [Sup5] immediately if the pass is clearly backward. Noting any backward pass signal from the wing officials. [IN 3xx FORMATION (CREW OF 6C/8)] Taking your time to ensure that you and your colleague do not make contradictory calls.
3. Observing fouls by all players generally in your area, but particularly:
 - (a) intentional grounding or any other illegal pass by the passer
 - (b) roughing the passer
 - (c) illegal block in the back and holding fouls by linemen and backs protecting the passer, especially the tackle or guard on the same side of the formation as you
 - (d) safety-related fouls such as face mask, tripping, illegal blocks below the waist, chop blocks or illegal blind-side blocks
 - (e) late hits by any player after the ball is dead

9.4.b – Response to what happens (movement and signals)

1. When a potential passer drops back, backpedal to remain wider and deeper than them. [REFEREE] [IN 2xx FORMATION (NO C)] If they roll out to either side, go the same way, staying wherever possible on their throwing arm side. Remain behind the line of scrimmage to observe the legality of the throw, the pass protection blocking and any action against the passer, particularly after they have thrown the ball and until there is no threat of a foul.
2. [REFEREE] Verbally alert defenders when the passer has released the ball (e.g. "ball's gone").
3. Maintain a position to observe offensive and defensive action behind the line after the ball has gone downfield.
4. On a sack or tackle behind the line of scrimmage, sound your whistle to stop play. Keep watching the ball carrier until any threat of a continuing action foul against them has passed. [IN xx0/xx1 FORMATION (CREW OF 4/5/6C)] Get to a position level with the ball carrier to mark forward progress. Use your bean bag to mark the spot if you have to go with the ball carrier as they are driven back.

9.4.c – Advanced techniques

1. If you believe the passer intentionally grounded the pass, move to the spot of the pass and consult with other officials about the position of eligible receivers and/or whether the pass crossed the neutral zone in flight. It is permissible to throw your flag to the spot of the pass if you cannot immediately get to it. An official may inform you that an eligible receiver was in the area of the pass, or that the pass (from outside the tackle box) crossed the neutral zone. It is appropriate to wave a flag off if this happens, but ensure that players and Head Coaches (and spectators, if possible) are informed of the reason.
2. If you observe the pass being tipped, give the ball touched signal [S11]. The signal should normally be used on passes tipped in the offensive backfield, but inconspicuous (to the spectators) touching downfield could be signified in this way too. It is not necessary to give it when the pass is obviously touched (e.g. when a defensive lineman bats it into the ground).

3. When the potential passer is about to be hit, focus on the ball and the defenders, not the passer. This will make it easier for you to rule pass/fumble or roughing the passer.
4. [REFEREE] [IN xx0/xx1 FORMATION (CREW OF 4/5/6C) OR IN GOAL LINE SITUATIONS] If there is a possibility that the pass was thrown from beyond the neutral zone, move to the spot of the pass and drop a bean bag there. Keep officiating until the play is over, then come back and check the position of your bean bag in relation to the neutral zone. Consult with colleagues who may also have had a view of the location of the pass. If the pass was illegal, throw a flag at the position of the bean bag. If you are confident the pass was illegal, it is permissible to drop the flag rather than the bean bag. [IN xx2/xx3 FORMATION (CREW OF 6D/7/8)] This responsibility is primarily the Line Judge's (except if they have moved to cover the goal line).
5. Do not watch the ball after the pass is thrown. Concentrate on the passer until there is no threat of further action against them.
 - (a) [IN 3xx FORMATION (CREW OF 6C/8)] It is permissible for *either* the Referee or the Centre Judge to switch their attention away from the passer once the ball is thrown and any immediate threat to them has gone. The official *away* from the side of the field to which the pass is thrown needs to stay with the passer. If the pass is thrown down the middle of the field, both officials should stay with the passer.

9.5 - Goal line plays

9.5.a – Priorities

Same priorities as on other scrimmage plays.

9.5.b – Initial positioning

1. [SNAP FROM OUTSIDE TEAM A'S 10-YARD LINE] If your normal position would be *near* Team A's goal line, take up position *on* the goal line, moving wider than normal if necessary. You also have responsibility to cover Team A's end line.
 - (a) [IN 3xx FORMATION (CREW OF 6C/8)] You may need to take position just in front of or just behind the goal line in order that you do not block your colleague's view of the full line. §
2. [SNAP FROM BETWEEN TEAM A'S 5 AND 10-YARD LINES] Take up a position wider than normal and be prepared to move to the goal line to rule on a possible safety. You also have responsibility to cover Team A's end line.
3. [SNAP FROM ON OR INSIDE TEAM A'S 5-YARD LINE] Take up a position on the end line (the wing officials have responsibility for the goal line.)
4. [OTHERWISE] Adopt the same position and coverage as for any other scrimmage play.

9.5.c – Response to what happens (movement and signals)

1. Respond to the play as you would normally do for a run or pass.
2. Do not give a score signal if you have thrown a penalty flag for a foul by the scoring team. Do not blow your whistle or give any signal if you are not sure about the outcome of the play.
3. [REFEREE] When an official gives the touchdown [S5] or safety [S6] signal, check that no penalties have occurred, step clear of the players, and signal the score to the press box. Hold the signal for approximately 5 seconds. There is no need to whistle.

9.5.d – Advanced techniques

1. [REFEREE] When there is a score:
 - (a) Should any doubt exist about the score, consult all the officials concerned before signalling your decision.
 - (b) Only be the first official to signal a touchdown or safety if you are the primary Coverer on the goal line. Give a preliminary signal while continuing to monitor players in your area of responsibility, then drop the signal while you check for flags. Once you are certain that the score is valid, give a second, final signal to the press box and hold it for approximately 5 seconds.

9.6 - Returns

9.6.a – Priorities

1. Observing the ball carrier and action around them while you are the nearest official.
2. Observing any fumble where you are the nearest official or have the best view, and marking the spot with a bean bag.
3. Observing blocks by players in your area of responsibility ahead of and around the ball carrier, particularly:
 - (a) illegal block in the back and holding fouls at the point of attack
 - (b) illegal block below the waist fouls anywhere
 - (c) safety-related fouls such as face mask, tripping, chop blocks or illegal blind-side blocks
 - (d) assisting the runner
 - (e) contacting an opponent with the crown of the helmet or targeting a defenseless opponent above the shoulders
 - (f) late hits by any player after the ball is dead

4. Observing any *legal*^o hand-off or pass where you are the nearest official or have the best view, and marking the spot with a bean bag.
5. Observing any *illegal* forward pass or forward handing, especially if you have a view that is level or nearly level with the ball carrier.
6. [REFEREE] Observing any foul on the passer or kicker.

9.6.b – Response to what happens (movement and signals)

1. Keep out of the players' way.
2. Backpedal towards Team A's goal line ahead of the play. If it is no longer possible to backpedal, turn and watch the play over your shoulder. [REFEREE] Keep the passer or kicker in your field of view.
3. If the play advances far enough to threaten Team A's goal line, be there before the ball carrier.
[IN 3xx FORMATION (CREW OF 6C/8)]:²
 - (a) [CENTRE JUDGE] Prioritise getting to Team A's goal line.
 - (b) [REFEREE] Prioritise watching the passer or kicker.
4. If you are watching a block develop, stay with it before switching to the ball carrier or another block. Even if you expect another official to take responsibility for it, stay with the block until you are confident it is legal.
5. If the ball becomes dead in your area of responsibility, blow your whistle, give the timeout signal [S3], and then signal first down [S8] to show which team is in possession.
6. If you are not the nearest official to the dead-ball spot, nevertheless move towards it and observe the continuing action after the ball becomes dead. On plays when the ball carrier goes near the sideline or out of bounds, move laterally to cover the area around them for extra-curricular activity. If you are the second official to the area, go out of bounds after the ball carrier and watch for and prevent fouls on them (MOFO 6.8).

9.6.c – Advanced techniques

1. Do not get too close to the play – move away from it if necessary to maintain a safe position, especially on the goal line.

9.7 - Punts

9.7.a – Priorities

Before and during the kick, applying the same priorities as on basic scrimmage plays (above), plus:

1. Noting players with numbering exceptions when the snapper is established and determining the legality of the formation.[†]
2. If the punter is in their end zone, observing whether they step out of bounds prior to the snap or between the snap and the kick.
3. Observing fouls by all players generally in your area, but particularly:
 - (a) any action against the kicker that might be roughing or running into
 - (b) illegal blocks below the waist, especially by backs
 - (c) before the kick, illegal block in the back and holding fouls by linemen and backs protecting the kicker, especially the tight end and/or wing back on the same side as you
 - (d) safety-related fouls such as face mask, tripping, chop blocks or illegal blind-side blocks
 - (e) unnecessary roughness fouls away from the ball
 - (f) late hits by any player after the ball is dead
 - (g) illegal formation
 - (h) Team A players going out of bounds during the down
4. Responding to bad snaps or blocked kicks by first observing the ball or the kicker (whichever is deeper) and action around them, and then adopting run, pass or return priorities as appropriate.

During a punt return, applying the same priorities as on returns (above).

9.7.b – Initial positioning

1. Take a position 2-5 yards deeper than the kicker and slightly wider than the normal tight end position.[†]
2. [IN xx0 FORMATION (CREW OF 4)] Favour the Line Judge's side of the field, and be alert for illegal movement of interior linemen on the Line Judge's side. [IN 3xx FORMATION (CREW OF 6C/8)] Agree which side of the formation you will take, but normally stay on the same side you were for the previous plays.² [OTHERWISE] Favour the side of the field of the kicker's kicking foot.
3. Be in a position to see the ball from snap to kick, and to be able to see the blockers and the kicker at the same time.

9.7.c – Response to what happens (movement and signals)

1. [REFEREE] Verbally alert defenders when the kicker has kicked the ball (e.g. "ball's gone").
2. Only if the kicker is not threatened, and the trajectory of the kick is towards a sideline, move quickly behind the kicker into line with the flight and be prepared to direct the official covering the sideline to the out of bounds spot using signals [Sup17, Sup18 & Sup19]. [IN 3xx FORMATION (CREW OF 6C/8)] Only the

official on the side that the ball is kicked *away* from should do this, and should not need to move much to do so.

3. After the kick:
 - (a) [IN xx0 FORMATION (CREW OF 4)] Move out to cover play in the side area vacated by the Line Judge.
 - (b) [OTHERWISE] Move to the middle of the field (between the hashes) so as to best observe a return to either side of the field. Stay back after the players move downfield.
 - (c) In either case, be the deepest official covering the return run.
 - (d) [REFEREE] Keep the kicker in sight in case they are targeted by an opponent.
4. During the punt return, respond as for any other return play.
5. If the play turns into a run or pass, respond as you would do normally for that type of play.

9.7.d – Advanced techniques

1. Particularly check for the correct number of players on Team A. Teams get mixed up more often on punt plays than any other.
2. [REFEREE] Warn the kicker if they are near, on or outside the endline prior to the snap.
3. Ideally, when the ball is kicked, you are at a 45-degree angle to the kicker and able to observe them, the ball and players trying to block the kick.
4. [REFEREE] Watch the snap into the punter's hands, then look at the onrushing Team B players and focus on the ones who are most threatening to contact the punter.
5. If there is a bad snap or the kick is blocked, move away from the ball and players trying to recover it. Move to a position to cover any or all of the Team A goal line, the Team A end line, and [IN xx0 FORMATION (CREW OF 4)] the Line Judge's side line.
6. Be alert for blocked kicks and their recovery and advance. On fake kicks switch to normal run or pass coverage.
 - (a) While a kick is loose in the backfield:
 - (i) [IN 2xx FORMATION (NO C)] Continue to watch the ball and players trying to recover it – other officials will watch the kicker.
 - (ii) [IN 3xx FORMATION (CREW OF 6C/8)] The official nearest to the ball should continue to watch the ball and players trying to recover it. The other official should watch the kicker and players threatening them.
 - (b) If the ball is blocked and the kicker is roughed/run into, the Umpire may be able to help you determine whether it was the player who blocked the kick who contacted the kicker.
 - (c) If the ball is snapped over the punter's head, be particularly observant for players illegally kicking a loose ball, and for holding by players of either team trying to prevent opponents recovering the ball.

9.8 - Field goal & try attempts

9.8.a – Priorities

Before and during the kick, applying the same priorities as on basic scrimmage plays (above), plus:

1. [NOT CENTRE JUDGE IN 3x1 FORMATION (CREW OF 6C)] Noting players with numbering exceptions when the snapper is established and determining the legality of the formation. †
2. Observing fouls by all players generally in your area, but particularly:
 - (a) any action against the kicker or holder that might be roughing or running into
 - (b) illegal block in the back and holding fouls by linemen and backs protecting the kicker and holder, especially the tight end and/or wing back on the same side as you
 - (c) contacting an opponent with the crown of the helmet or targeting a defenseless opponent above the shoulders
 - (d) safety-related fouls such as face mask, tripping, chop blocks or illegal blind-side blocks
 - (e) late hits by any player after the ball is dead
 - (f) illegal formation
 - (g) [IN 2x0/2x1 FORMATION (CREW OF 4/5)] false starts by interior linemen, ends and backs on the Line Judge's side of the formation
3. [CENTRE JUDGE] [IN 3x1 FORMATION (CREW OF 6C)] Ruling the success or failure of the field goal attempt. You share this responsibility with the Back Judge.
4. Responding to bad snaps or blocked kicks by first observing the ball or the kicker, whichever is deeper, and action around them, and then adopting run, pass or return priorities, as appropriate.

During a field goal return, applying the same priorities as on returns (above).

9.8.b – Initial positioning

1. [REFEREE] Be 5-10 yards wider and 3-7 yards deeper than the holder (or the expected spot of the kick). ◊
 - (a) [IN 2x0/2x1 FORMATION (CREW OF 4/5) IF THE LINE JUDGE IS BEHIND THE POSTS][‡] Be on the Line Judge's side of the field. [OTHERWISE] Be on the side of the field opposite the kicker's foot. ◊
 - (b) [IN 3x1/2x2/2x3 FORMATION (CREW OF 6C/6D/7)][‡] Normally be on the side of the field opposite the kicker's kicking foot.

- (c) [IN 3x3 FORMATION (CREW OF 8)] Agree with the Centre Judge which side of the formation you will take, but[‡] normally stay on the same side of the field you were for the previous plays.
2. [CENTRE JUDGE]
- (a) [IN 3x1 FORMATION (CREW OF 6C)] Be in position about one yard behind the goal post nearest the press box. You are responsible for ruling whether the ball passes inside your upright. The Back Judge has responsibility for the other upright and crossbar.
- (b) [IN 3x3 FORMATION (CREW OF 8)] Be in position opposite the Referee, 5-10 yards wider and 3-7 yards deeper than the kicker and holder. Agree with the Referee which side of the formation you will take, but normally stay on the same side you were for the previous plays.
3. Ensure that you are facing towards the kicker and holder, and that you are able to observe both the snap and the holder.

9.8.c – Response to what happens (movement and signals)

1. [REFEREE][‡]
- (a) Maintain a position where you can see the kicker, holder and players threatening them.
- (b) You have primary responsibility for the kicker and holder.
- (c) Wait until the ball is dead and there is no threat to players in your area before looking to the official(s) at the goal posts to find out the result of the kick.
- (d) Once all the players are completely separated, step away from players and signal the result of the play to the press box. If the kick is good, hold the signal [S5] for approximately 5 seconds.
2. [CENTRE JUDGE]
- (a) [IN 3x3 FORMATION (CREW OF 8)]
- (i) Maintain a position where you can see the kicker, holder and players threatening them.
- (ii) Observe action on the wing back and tight end on your side and help on blocks that are deep in front of the kicker and holder. Also assist the Referee with calls relating to the kicker and holder, particularly at the time of the kick.[§]
- (b) [IN 3x1 FORMATION (CREW OF 6C)]
- (i) Observe the ball from kick to when it becomes obvious whether the attempt will be successful or not.
- (ii) If you consider the kick to be successful, communicate ("good", nod) with your colleague behind the posts and together come out between the uprights (approximately one yard into the end zone) giving the score signal [S5] as you come to a stop.
- (iii) If you consider the kick to have failed, give the no score signal [S10]. If the kick is wide to your side, you may also give the kick wide signal [Sup15]. Do *not* signal a touchback unless Team B has touched the ball beyond the neutral zone.[§]
- (iv) Hold either signal for at least five seconds and until you know the Referee has seen it.
- (v) If the kick is short or blocked and the ball is possessed by Team B, move into position to officiate the kick play as a punt return.[‡]

9.8.d – Advanced techniques

1. Be alert for blocked kicks and their recovery and advance. On fake kicks switch to normal run or pass coverage.
- (a) If there is a bad snap or the kick is blocked, move away from the ball and players trying to recover it. If there is a substantial return, move to a position to cover any or all of the Team A goal line and end line, and [IN 2x0/2x1 FORMATION (CREW OF 4/5)][‡] the Line Judge's side line.
- (b) While a kick is loose in the backfield:
- (i) [IN 2xx FORMATION (NO C)] Continue to watch the ball and players trying to recover it – other officials will watch the kicker.
- (ii) [IN 3x3 FORMATION (CREW OF 8)] The official nearest to the ball should continue to watch the ball and players trying to recover it. The other official should watch the kicker and players threatening them.
- (c) [IN 2x0/2x1 FORMATION (CREW OF 4/5)][‡] On a play that develops into a run to the Line Judge's side of the field, attempt to get to the goal line ahead of the ball carrier if you can.
2. [REFEREE] If Team A attempts a surprise drop goal (i.e. there is no official behind the goal), your priority is to rule on the success/failure of the kick rather than stay with the kicker (roughing the kicker cannot by rule occur if it is not obvious a kick will be made). Run after the ball towards the goal and get the best view you can of whether the kick is successful or not. Consult with other officials (e.g. the Back Judge) who may have been in position to assist before signalling the outcome.
3. [IN 3x1 FORMATION (CREW OF 6C)] On long field goal attempts (i.e. if the ball is snapped from outside Team B's 20-yard line), it is permissible for only the Back Judge to go behind the goal posts and for the Centre Judge to initially be in their normal position in the offensive backfield. This is known as the "One Judge" mechanic. The Centre Judge must clearly communicate to all other members of the crew their intention in this situation.

4. [IN 3x1 FORMATION (CREW OF 6C)] [CENTRE JUDGE] If you are behind a goal post:[§]
- (a) Note the numbers of the (normally) two eligible receivers on your side of the offensive formation so that, if a pass develops, you can rule on ineligible touching a pass or being illegally downfield.[§]
 - (b) Be alert for cases where the kick is blocked or where there is a bad snap. This also applies if Team A switches to a run or pass formation.
 - (i) Stay in position as long as there is the possibility of a drop kick attempt.
 - (ii) [‡] If a run or pass develops, read the play and respond as appropriate.
 - (1) If the play develops to one side of the field and you are the nearer of the two officials behind the goal, move towards the sideline.
 - (2) On an obvious running play or pass play short of the goal line, you may need to come infield and cover the goal line. This is normally the official behind the post furthest from the play, in order to help box in the goal line with any trailing wing official.[§]
 - (3) Stay on the end line if a pass into the end zone is possible.[§]
 - (iii) If the ball is recovered and advanced by Team B, follow the return up the field.
 - (c) If Team A switches to a run or pass formation, move to the position normally occupied by a Field Judge. You need to get to your goal line pylon as quickly as possible (diagonally across the end zone if safe to do so). During the play, be aware of the wing official's position and if they are going to get to the goal line first, you should divert to the end line pylon. At all times cover play in the end zone.[§]
5. Be aware of colleagues' positions and movements and adapt to box the play in as best as possible.[◊]

9.9 - After each down

9.9.a – Priorities

1. Observing dead-ball action by players of both teams.
2. Encouraging the players to unpile safely, and either return the ball to an official or leave it near the dead-ball spot, as appropriate.
3. Checking whether the line to gain has been reached or is close, and signalling appropriately.
4. Checking whether any penalty flags have been thrown, and, if so:
 - (a) Giving the timeout signal [S3].
 - (b) [REFEREE] Finding out what fouls have been called and administering them according to the procedures in Chapter 19.
 - (c) [REFEREE] Keeping the Umpire informed.
 - (d) [CENTRE JUDGE] Reporting any fouls you have called to the Referee.
 - (e) Ensuring that all penalties are enforced correctly.
 - (f) [CENTRE JUDGE] Keeping the wing officials informed of the penalty and its enforcement.
5. [REFEREE] Determining whether a new series is to be awarded, based either on a colleague's signal that the ball definitely has reached the line to gain, your own visual inspection of the ball in relation to the line to gain, or after a measurement you have ordered.
6. Checking for injured players or other occurrences that may delay play.
7. [ON-FIELD PLAY CLOCK OPERATOR] Starting the play clock when necessary, giving a 10-second warning, and throwing a delay of game flag if the clock reaches 0 before the ball is put in play.
8. Allowing legitimate requests for timeouts. Checking that a request coming from the coaching box or team area was made by the Head Coach.
9. Echoing all timeout signals [S3] of your colleagues.
10. Assisting in relaying the dead ball or a new ball to the succeeding spot.
11. Spotting the ball at the succeeding spot if you are nearer to it than the Umpire.
12. Ensuring all officials are in (or near) position for the next down before allowing the ball to become ready for play.
13. [×] Noting the lateral placement of the ball using elastic bands or some other device. The system for denoting lateral position is described in paragraph 6.6.10.
14. [CENTRE JUDGE] Standing over the ball if any of the conditions of MOFO 10.9.c.14 apply.

9.9.b – Initial positioning

1. Shortly after the end of the previous down, you should be in a position in the vicinity of the succeeding spot. The precise position will depend on what happened on the previous play.

9.9.c – Response to what happens (movement and signals)

1. If you are the Coverer, give only *one* signal that the ball is dead. See paragraph 6.5.14.[‡]
2. If a penalty flag has been thrown follow the procedure in Chapter 19. If an inadvertent whistle has been blown, follow the procedure in Section 6.15.[§] If a team or injury timeout has been called, follow the procedure in Chapter 17. If a period has ended, follow the procedure in Chapter 20.
3. [CENTRE JUDGE] At the end of a play, observe dead-ball action while moving towards the dead-ball spot, or the inbounds spot if the ball is outside the hash marks.

4. [ON-FIELD PLAY CLOCK OPERATOR] If a 40-second clock should start by rule:
- If there is a stadium play clock, check that it started shortly after the end of the play.
 - If there is no stadium play clock, start a 40-second count shortly after the end of the play.

Spotting the ball for the next down:

5. Assist in relaying a ball to the Umpire or Centre Judge or spot the ball that someone else has relayed to you (MOFO 6.7). [REFEREE] [IN 3xx FORMATION (CREW OF 6C/8)] Generally, you should not handle the ball unless it becomes dead very close to you. Normally, leave spotting the ball responsibilities to the Umpire or Centre Judge.
6. If you are spotting the ball:
- Before doing so, quickly check that there are no injured players.®
 - Face the Coverer, not the goal line, when spotting the ball. Take the forward progress from the Coverer and place the ball at the succeeding spot. Following an incomplete forward pass, penalty, etc., verify with the Umpire that the lateral placement of the ball is correct.
 - Place the ball laces down if there is any risk of it rolling away from its position.
7. [CENTRE JUDGE]
- In hurry-up situations, when the clock is running, go get the ball wherever it is (unless the Referee or Umpire is clearly nearer) (MOFO 6.2.10).
 - Don't worry about who spots the ball; the most convenient official to the succeeding spot should do it; other officials should assist in relaying a ball to them if necessary (MOFO 6.2.10). However, in a hurry-up offense, it is best to leave the Referee to monitor substitutions by Team A and for the Centre Judge (and Umpire) to deal with the ball.
 - If the 40-second play clock is already running, step away to your position, to make the ball ready for play.® If the 40-second play clock is not running, wait over the ball until the Referee indicates that the ball is ready for play, then step away from it.
 - After spotting the ball, look to the Referee to determine if you must remain near the ball to prevent the snap or if you may assume your normal position.
 - If you spotted the ball but need to prevent the snap, move to a position behind and to the side of the snapper. § This position allows you to stay clear of the linemen's feet as they get set and to avoid having to step over or through the gap between the snapper and the guard. This also places you in front of or to the side of the quarterback so that they also can clearly see that the snap is being prevented.
 - When stepping away from the ball, back into position facing the Referee and quarterback.
 - If there is a late substitution and the Referee extends their arms [Sup36] indicating that the snap should not occur, go to/remain next to the snapper and warn them not to snap the ball.
 - Whether you or the Umpire spotted the ball, if someone needs to return to stand over it to prevent play, normally this would be you.

Getting ready for the next down:

8. [REFEREE]
- If you are certain the line to gain has been reached, give the first down signal [S8] and ensure that the Down Judge has seen it and that the chain crew are responding to it.
 - If you are unsure whether the line to gain has been reached, move to the dead-ball spot and either make a decision based on your view of the ball in relation to the line to gain, or order a measurement by repeating the timeout signal [S3] and tapping your chest. Ensure that all your colleagues are aware of your decision.
 - Check the number of the next down with the Down Judge. Indicate and announce the new down and (if unusual or unexpected) the approximate distance to the line to gain. It is sufficient to use one of the following terms (in increasing order): "inches", "short", "long", "ten", "two stakes".
 - Give the untimed down signal [S1*] for each down when a period is extended (other than a try if a touchdown is scored during an untimed down). Do not give the untimed down signal on a try.
 - Check that all other officials (particularly the Umpire) are in or near their position for the next down and are ready to officiate.
 - If necessary, check the status of the clock with the on-field timekeeper.
9. [CENTRE JUDGE] You and the Umpire must between you perform the duties specified in paragraphs 10.9.c.13 to 10.9.c.22.
10. Move into position for the next down. Backpedal if necessary to keep your eyes on the ball. Do not take your eyes off it in case the play starts while you are not looking.
11. Make sure that you are in a position to see the ball, the Umpire and both wing officials.

Ready for play:

12. [REFEREE]
- If the 40-second play clock is already running:
 - If the ball is not ready for play 20 seconds into the play count (Rule 3-2-4-b-3):
 - Signal that the play clock be reset to 25 seconds [Sup29].
 - If that happens immediately, then proceed as normal, otherwise:
 - Declare a referee's timeout [S3].
 - Signal again that the play clock be reset to 25 seconds [Sup29] and continue to signal until the clock responds.

- (c) When the ball is ready, continue as below.
 - (ii) If the game clock should start on the "Ready", [as soon as the ball is ready for play \(i.e. an official has placed it at the succeeding spot and is then in position to officiate\)](#),[®] give the start the clock signal [S2]. Only blow your whistle if needed to attract the attention of the clock operator. Without a whistle, this is a so-called "silent wind".
 - (iii) Otherwise, there is no need to give a ready-for-play signal.
- (b) If the 40-second play clock is not running:
 - (i) If the game clock was stopped for a player injury, give a signal [either Sup29 or Sup30] to indicate whether the play clock should be set to 25 or 40 seconds.
 - (ii) [When the ball is ready for play \(i.e. an official has placed it at the succeeding spot and is then in position to officiate\)](#),[®] blow the whistle and give the ready for play signal [S1]. If the game clock should start on the "Ready", follow that with the start the clock signal [S2].
 - (iii) [\[ON-FIELD PLAY CLOCK OPERATOR\]](#)[‡] Unless there is a stadium play clock, start your 25-second clock when you declare the ball ready.
 - (iv) In 10-second runoff or unfair clock tactics situations, make sure that the timekeeper (or stadium clock operator) knows that the game clock is not starting normally.
- (c) If there are stadium game and/or play clocks, check to see that they have started correctly.

Play clock administration:

13. [REFEREE]

- (a) [\[IN xx1/xx2/xx3 FORMATION \(CREW OF 5/6/7/8\)\] \[USING O2O/CREW RADIO\] When you hear the 10-second alert from the play clock operator,](#)[§] or when you see the Back Judge or the Side Judge raise their hand, give a verbal warning to Team A ("10 seconds" or "hurry" if you are not sure how many of the 10 seconds have expired).
- (b) [\[ON-FIELD PLAY CLOCK OPERATOR\]](#)[‡]
 - (i) When approximately 10 seconds remain on the play clock, give a verbal warning to Team A ("10 seconds" or "hurry" if you are not sure how many of the 10 seconds have expired).
 - (ii) When the play clock reaches 0, look at the snapper. If the ball is already moving, there is no foul. Otherwise, blow your whistle and throw your flag for delay of game.

9.9.d – Advanced techniques

1. The priority at the end of a play is to get into position ready for the next one. Only if a serious incident occurs (such as a foul or misconduct, an injury, or a breakage of the chain) should your routine be interrupted.
2. If Team A makes substitutions **while the snapper is at, near or moving towards** their position at the line of scrimmage:
 - (a) Any official should be prepared to step in and shut down a play that violates the substitution rule.
 - (b) [REFEREE]
 - (i) Give the matching substitutes signal [Sup36] to [\[IN 3xx FORMATION \(CREW OF 6C/8\)\]](#) the Centre Judge [\[IN 2xx FORMATION \(NO C\)\]](#) the Umpire to get over the ball and prevent the snap.
 - (ii) Drop the signal if Team B do not begin substitutions within 3 seconds.
 - (iii) [Drop the signal when Team B has completed its substitutions or any replaced player is not leaving the field quickly, or any substitute is not entering the field quickly.](#)[®]
 - (iv) If the officials are unable to stop Team A from snapping the ball before Team B has completed its substitutions, stop play and warn Team A that further attempts will be penalised with [a Delay of Game and then Unsportsmanlike Conduct fouls.](#)[®]
 - (c) [CENTRE JUDGE]
 - (i) [Anticipate that the Referee may give the matching substitutes signal \[Sup36\] by moving to a position where you can get to the ball before the snapper can.](#)[°]
 - (ii) [If the Referee gives the matching substitutes signal \(or forgets to do so when Team B is responding to Team A substitutes\),](#)[°] take a position over the ball to prevent Team A from snapping it until Team B has had an opportunity to place its substitutes into position and its replaced players have left the field of play.
 - (iii) While standing over the ball, plan the route you will take to get away from the players before the ball is snapped.
 - (iv) When Team B has completed its substitutions (or does not make any), inform the snapper/QB not to snap the ball until they receive verbal approval from you. If they snap the ball before they are given verbal approval, Team A will be assessed a Delay of Game foul after a warning for the first offence (MOFO 3.4.1.f). [\(Warn for first offence and penalise second and subsequent.\)](#)[‡]
3. [\[REFEREE\]](#) [§] If one or more players enter the game having changed jersey numbers, they must report to you.
 - (a) [\[USING PUBLIC RADIO\]](#) Without changing position, announce each player's former number and new number.
 - (b) [\[USING O2O/CREW RADIO\]](#) If that information hasn't reached the appropriate sideline official, ask them to relay the information to the opposing head coach.
 - (c) [During this process, the game clock and play clock do not stop.](#)

- | |
|--|
| <ul style="list-style-type: none"> (d) If any Team A players change their number, Team A must complete the process before the play clock expires. During the process, the officials will not allow the ball to be snapped, which may lead to a Delay of Game foul. (e) If any Team B players change their number, they must get into position on their side of the line of scrimmage before the ball is snapped or be subject to a foul. During the process, the officials will not prevent Team A from snapping the ball. (f) Normal substitution rules still apply. |
|--|
4. [REFEREE] If Team A is attempting to make a quick start to the play, inform both teams that the ball must not be snapped until the whistle is sounded. Move quickly to your position, indicate to the Umpire (or Centre Judge) that they may move to their position, check that all other officials are ready, and then blow your whistle.
 5. If Team A are running a hurry-up offense, do not stop them just because you or another official is not perfectly in position (MOFO 6.2.16.a). Adapt and officiate as best you can as you move to a position to cover the play.
 6. Procedures intended to allow the defense to match up must not be used for a substitution for a last-second field goal. In that situation, Team A is making a normal and expected personnel change and Team B should be prepared to respond appropriately. In no case should an official be standing over the ball to prevent the snap as the clock runs out. [§]
 7. If you want to speak to a player on the field (e.g. to warn them that they are close to fouling), it often saves time to relay the message via the Umpire or Back Judge (for a Team B player). Don't delay the game unnecessarily by entering either team's huddle, unless a timeout is still in progress. Never attempt to speak to a player during a hurry-up or no-huddle offense.
 8. Maintain your concentration, and think about the next play.

10. UMPIRE

10.1 - Free kicks

10.1.a – Priorities

Prior to the kick:

1. Being aware of whether the Referee has instructed the crew to switch to onside-kick positions, and moving position (if appropriate) if they have.
2. If the free kick takes place after a score, timing the one-minute intermission, starting from when the Referee signals the score to the press box (Rule 3-3-8-f).
3. Counting Team A players and signalling the count [one of Sup3, Sup4 or Sup24] to colleagues. Noting count signals from colleagues. Recounting if your count differs from that of colleagues.
4. Reminding the players to count their number if the team you are responsible for counting does not have precisely **the correct number of²** players on the field.
5. Handing the ball to the kicker (or leaving it in the middle of the field on Team A's restraining line if the kicker delays setting up for the kick).
6. Briefing the kicker, including:
 - (a) Cautioning the kicker not to kick the ball if it falls off the tee.
 - (b) Reminding the kicker that other kicking team players must be no more than 5 yards behind their restraining line.
 - (c) Being sure that they understand that they must not kick the ball until the Referee sounds their whistle.
 - (d) Reminding the kicker that they have 25 seconds to put the ball into play after the Referee sounds their whistle.
 - (e) Reminding them that they are responsible for removing the kicking tee from the field at the end of the play.

You may skip the briefing if you're sure the kicker remembers it all from previous briefings, or if the kicker is not around to be briefed.

7. Checking readiness for play:
 - (a) [IN F4 FORMATION (CREW OF 4)] Checking side areas to ensure that all non-players are out of the restricted areas, that non-participants are off the field of play, **that the safety zone is clear,[®]** and that all team personnel are within the team area.
 - (b) Ensuring that the chain crew (and the alternate down box and line-to-gain marker operators, where provided) have moved themselves and their equipment well out of the way and that the equipment has been placed on the ground outside the team areas and **outside the safety zone[®]** at the receiving team's end of the field. Checking that the ball persons are in position.
 - (c) Checking that the kicking team has at least **the minimum number of** players on either side of the kicker, and reminding them to count if they do not.
 - (d) Reminding colleagues on the restraining lines to get into position and get ready if they have not already done so.
 - (e) Noting (when satisfied that all is ready) the readiness of the officials on the restraining lines, then holding your arm aloft until the ready signal is given by the Referee.
 - (f) Getting the ball ready for play as quickly as possible. Reminding the Referee to declare the ball ready promptly when all officials are in position. Doing this even if Team A is not ready.
 - (g) [IN F5-8 FORMATION (CREW OF 5/6/7/8)] Staying between the kicker and the ball until the Referee gives the ready for play signal.
 - (h) Being alert always for short kicks.

During the kick play:

8. [IN F4 FORMATION (CREW OF 4)] Observing whether a free kick goes out of bounds nearest to you without being touched by the receiving team. Ruling whether a Team B player near the sideline touches the ball while out of bounds.
9. Watching players for a fair catch signal, and being prepared to rule on any interference with the opportunity to catch the kick.
10. If^x the kick is short:
 - (a) Knowing whether the kicked ball has touched the ground and whether it was driven directly into the ground or goes a short distance and then touches the ground.
 - (b) Knowing where and by whom the ball was first touched.
 - (c) Observing illegal blocks by Team A (Rule 6-1-12).
 - (d) Marking any spot of illegal touching with a bean bag.
 - (e) [IN F4 FORMATION (CREW OF 4)] Marking the dead-ball spot if you are the nearest official and there is little or no return run.
11. Giving the start the clock signal [S2] only if the ball is first legally touched in the field of play **and you are the nearest official or you have the best view of it.**

12. [IN F4 FORMATION (CREW OF 4)] Marking the dead-ball spot if you are the nearest official when the ball carrier is tackled or goes out of bounds.
13. [IN F4-6 FORMATION (CREW OF 4/5/6)][‡] Ruling a touchdown at Team A's goal line.
14. Observing fouls/violations by all players generally in your area, but particularly:
 - (a) all actions against the kicker until a roughing the kicker foul is no longer possible by rule
 - (b) illegal touching of a short kick
 - (c) infractions of your restraining line
 - (d) kicking team players (other than the kicker) more than 5 yards behind their restraining line after the ready for play
 - (e) [IN F4 FORMATION (CREW OF 4)] blocks made by the three players from Team B who were nearest you at the kick
 - (f) [OTHERWISE] blocks made by the middle player on Team B's front line at the kick
 - (g) illegal blocks in the back and holding fouls at the point of attack
 - (h) illegal blocks below the waist
 - (i) contacting an opponent with the crown of the helmet or targeting a defenseless opponent above the shoulders
 - (j) safety-related fouls such as face mask, tripping, chop blocks, illegal wedges or illegal blind-side blocks
 - (k) late hits by any player after the ball is dead
 - (l) any player of the kicking team who enters the field of play after the kick or who voluntarily goes out of bounds during the kick and returns inbounds
 - (m) illegal forward handing or illegal forward passes
15. [IN F5-8 FORMATION (CREW OF 5/6/7/8)] Directing the nearest official to the out of bounds spot if the kicked ball goes out of bounds in flight.

10.1.b – Initial positioning

Normal kicks:

1. [IN F4 FORMATION (CREW OF 4)] After briefing the kicker and handing them the ball, move to position F (see 26.1) outside the sideline on the press box side on Team A's restraining line.
2. [OTHERWISE] Until the referee declares the ball ready for play, stand between the kicker and the ball to prevent them from kicking it. Once the ball is ready for play, move to position H (see 26.1) slightly to one side of the kicker (to their kicking foot side if possible), making sure that you do not impede their actions and are in position to see kicking team players who are more than 5 yards behind their restraining line.

Onside-kicks:

3. As per 10.1.b.2 above.[‡]

Free kicks after a penalty or safety:

4. When a free kick is taken following a penalty or a safety, the same relative positions should be taken, moving up or down the field as appropriate.

10.1.c – Response to what happens (movement and signals)

Prior to the kick:

1. Watch the ball prior to the kick and blow your whistle if it starts to fall off the tee before it is kicked. Give the timeout signal [S3] to indicate that there has been no play.[§] After the ball has been blown or fallen off the tee twice, insist that the kicking team use a holder.
2. If anything happens that should prevent the kick taking place (e.g. a non-player enters or approaches the field of play), toot your whistle, give the timeout signal [S3] and deal with the problem.

During any kick play:

3. If you see any player of the kicking team voluntarily go out of bounds during the kick, drop your bean bag or hat to mark their exit, and your flag if they return.
4. If the clock should start when the ball is first legally touched in the field of play, give the start the clock signal [S2] if you are the nearest official or the one with the best view.

During a kick play that goes deep:

5. [IN F5-8 FORMATION (CREW OF 5/6/7/8)] If the ball goes out of bounds in flight, after the ball is kicked, go to the spot of the kick and assist other officials to locate the out of bounds spot using signals [Sup17, Sup18 & Sup19].
6. [IN F4 FORMATION (CREW OF 4)] Move downfield along the sideline while the kick is in the air. During the return, stay ahead of the ball carrier, keeping them boxed in[‡] between you and the downfield official. On a long run, be at Team A's goal line before the ball carrier. You have shared responsibility for the goal line.[◊] Mark the dead-ball spot if you are the nearest official when the ball carrier is tackled or is out of bounds.
7. [IN F5-8 FORMATION (CREW OF 5/6/7/8)] Move downfield slowly after the players. Keep all the players in front of you (with the exception of an unthreatened kicker).
 - (a) [IN F7-8 FORMATION (CREW OF 7/8)] On a long run, keep out of the way of the players, let the ball carrier go past you and continue to officiate from the inside out.
 - (b) [IN F5-6 FORMATION (CREW OF 5/6)] On a long run, stay ahead of the players and get to the goal line ahead of the ball carrier. You have shared responsibility for the goal line.[§] You also have[‡] responsibility

for the end line should that be threatened (e.g. after a fumble near Team A's goal line). When you are sharing responsibility for a line (or pair of lines) with other officials, adjust so that you get a complementary view of the play.

8. [IN F4 FORMATION (CREW OF 4)] If the ball goes out of bounds in your area, go to and hold the spot, dropping your flag if appropriate.

During a kick play where the kick is short:

9. Maintain a position where you can see the ball and the blocks by Team A players.
10. If the ball is immediately driven into the ground and goes into the air, when the ball becomes dead inform colleagues of that fact, especially if kick catch interference may be an issue.
11. Particularly **observe**² the blocks made by Team A players before they are eligible to touch the ball (Rule 6-1-12).
12. Know where and by whom the ball was first touched. Be particularly alert for a second touch by the kicker. Mark any spot of illegal touching with your bean bag (Rule 6-1-3).
13. [IN F4 FORMATION (CREW OF 4)] If you are the nearest official when the ball becomes dead, signal timeout [S3] and mark the dead-ball spot.

10.1.d – Advanced techniques

1. If the kick goes deep:
 - (a) [IN F7 FORMATION (CREW OF 7)] Angle across to favour the **Side Judge/Down Judge's** side of the field as you move down the field. You and the Back Judge each take responsibility for half of the middle of the field.
 - (b) [IN F8 FORMATION (CREW OF 8)] Stay in the middle of the field as you move down the field. You, the Back Judge and the Centre Judge each take responsibility for a third of the middle of the field. You should stay deepest of the three.
2. [IF USING ONSIDE-KICK POSITIONS] If an expected onside kick is kicked deep:
 - (a) [IN F4 FORMATION (CREW OF 4)] Stay in the centre of the field. You, the **Down Judge** and the Line Judge each take responsibility for one third of the field (Figure 26.1.C).
 - (b) [IN F5 FORMATION (CREW OF 5)] Angle across to the **Down Judge's** side. You and the Back Judge each take responsibility for half of the middle of the field (Figure 26.1.E).
 - (c) [IN F6-8 FORMATION (CREW OF 6/7/8)] Stay in the centre of the field. You and the other two officials on Team A's restraining line each take responsibility for one third of the middle of the field (Figures 26.1.G, 26.1.I and 26.1.J).
 - (d) In all cases, observe action ahead of the ball carrier in your portion of the field.
3. **After the ball is dead and all action is ceased, if you are the nearest official to the previous spot make sure that any kicking tee has been removed from the field.** [◇]

10.2 - Basic scrimmage plays

10.2.a – Priorities

1. Knowing the down and distance, and signalling the down to your colleagues. Noting the down signals given by colleagues. Checking that the down box displays the correct number. Not allowing play to start if there is a dispute about the down number.
2. Counting Team A players and signalling the count [one of Sup3, Sup4 or Sup24] to your colleagues. Noting count signals from colleagues. Recounting if your count differs from that of colleagues.
3. Observing false starts in general and, in particular, by interior linemen. **This includes when Team A never sets.**
4. **Observing other illegal shifts (no 1-second pause after simultaneous movement by Team A players).** [◇]
5. Observing line of scrimmage infractions by Team B that involve contact with or a reaction by a Team A player.
6. Observing the legality of the snap.
7. If there is a pre-snap foul, stopping all action by tooting on your whistle and giving the timeout signal [S3].
8. Anticipating whether the play is a run or a pass by reading the initial action of the interior linemen. If they move backwards it is likely that a pass play will develop. If they charge forwards or pull, it is likely that a running play will develop.
9. Being aware of where the line to gain is in relation to the line of scrimmage so that you don't have to look at the chain to know if the dead-ball spot is close to the line to gain.
10. Observing substitution infractions by Team A, For example:
 - (a) replaced players not leaving the huddle within 3 seconds of an incoming substitute entering it
 - (b) breaking the huddle with **too many**² players
 - (c) keeping **too many**² players in the huddle/formation for more than three seconds
 - (d) substitutes coming on to the field, communicating, and then leaving the field
11. Observing that defensive players do not use words or signals that disconcert opponents when they are trying to put the ball in play.
12. **Observing that defensive linemen do not make movements that are not normal.** [®]
13. Noting any ineligible receivers in the backfield between the tackles, because of the potential for illegal touching and ineligible receiver downfield fouls.

14. Observing the legality of the formation, in particular the requirement for a minimum number of[†] players numbered 50-79.
15. Managing the substitution process if Team A makes a substitution while the snapper is at, near or moving towards their position at the line of scrimmage.[§]
16. Spot checking players' equipment, and reminding them to check their chinstrap and mouthpiece if necessary.

10.2.b – Initial positioning

1. Be where you can see the ball at the snap and all interior linemen.
2. Normal scrimmage down position is in the defensive backfield approximately 5 to 7 yards deep from the line of scrimmage and between the offensive tackles.
3. The position must be varied to prevent teams being able to take advantage of it.
4. Be in a position from which you can officiate without obstructing players.

10.2.c – Response to what happens (movement and signals)

1. If defensive players move their position, ensure you can still see the ball and the interior linemen.
2. Keep out of the way of defensive players.
3. If Team A is in a scrimmage kick formation, verbally remind Team B players not to rough the snapper, nor to line up over the snapper, nor to contact any Team A player 3-to-1.[§]
4. If there is a foul before the snap, blow your whistle, throw your flag and signal timeout [S3]. Confer with the wing officials about the call (unless there is absolutely no doubt what it is) and then inform the Referee.
5. If a lineman moves before the snap, and they may have been threatened by movement of a defensive player, confer with both wing officials[‡] near the succeeding spot.

10.2.d – Advanced techniques

Reasons for varying (or not) your initial position:

1. Generally, the higher the standard of play and the faster the players, the deeper and wider you need to stand. [IN xx2/xx3 FORMATION (CREW OF 6D/7/8)] You can be 10 yards off the line of scrimmage if you are comfortable there (except in goal line situations, where you must be able to get to the line of scrimmage to rule on the legality of a pass).
2. Be deeper and wider if your mobility is hindered either by your condition or ground conditions (e.g. mud or uneven surface).
3. There is no need to coordinate your position to the position of the Referee.

Signalling the player count:

4. The latest time to make the player count signal is when the offensive team breaks its huddle (but it can and should be done earlier if possible). [IN 3xx FORMATION (CREW OF 6C/8)] You do not need to count and signal if you don't have time to do so because you have spotted the ball.

10.3 - Running plays

10.3.a – Priorities

1. Observing the action around and ahead of the ball carrier.
2. Observing any fumble where you are the nearest official or have the best view, and marking the spot with a bean bag.
3. Observing fouls by all players generally in your area, but particularly:
 - (a) illegal block in the back and holding fouls at the point of attack, especially those made by interior linemen
 - (b) safety-related fouls such as face mask, tripping, illegal blocks below the waist, chop blocks or illegal blind-side blocks
 - (c) late hits by any player after the ball is dead

10.3.b – Response to what happens (movement and signals)

1. If the action comes towards you, move laterally to get out of the way and allow the players to pass by you.
2. When the play develops between the tackles, your primary responsibility is to cover the action of players at the point of attack, then around the ball carrier and finally between you and the ball on longer runs.
3. When the ball carrier moves into a side zone, turn and move so that you keep the ball carrier and their lead blockers in view. Don't move towards the ball so far that you will get in the way if the ball carrier cuts back infield, but also go far enough that you don't get left behind if the play ultimately reaches the sideline.
4. [IN xx0 FORMATION (CREW OF 4)] You will likely be the second nearest official to the out-of-bounds spot after a long run. Move laterally far enough that you can get to the sideline quickly if action there demands it or your presence would serve to defuse a difficult situation.
5. Only blow your whistle if the ball carrier's forward progress ends directly in front of you and it is likely they are obscured from the sideline officials. Take the exact forward progress from the sideline officials.

10.3.c – Advanced techniques

1. Don't blow your whistle when the ball carrier's back is toward you or you are obscured by other players or officials² – they may have fumbled the ball without you seeing it. See leather! Be certain that the ball is dead.
2. If a pile-up of players forms, give the timeout signal [S3], converge on the pile, determine who has possession (MOFO 6.10) and encourage players to unpile safely.
3. If you're not the nearest official to the dead-ball spot, observe for late hits and other illegal acts. It is particularly your responsibility to observe action close to the wing officials as they are concentrating on the forward progress spot.

Particular types of run play:

4. On plays into the line, if the ball carrier is driven back after their forward progress is stopped, discourage players from joining the pile.
5. If the run ends near to the line to gain, assist the wing official by handing a ball to them so that they can mark the exact dead-ball spot.

10.4 - Pass plays**10.4.a – Priorities**

1. Keeping out of the way of the players, particularly eligible receivers crossing the field in your vicinity.
2. Ruling whether passes are caught or incomplete when the receiver is facing you.
3. Observing fouls by all players generally in your area, but particularly:
 - (a) ineligible receivers downfield
 - (b) [IN xx0/xx1 FORMATION (CREW OF 4/5/6C) OR IN A GOAL LINE SITUATION] illegal passes because the ball carrier has crossed the neutral zone
 - (c) illegal block in the back and holding fouls by linemen and backs protecting the passer, especially the centre and guards, and [IN 2xx FORMATION (NO C)] the tackle on the side of the formation opposite the Referee
 - (d) safety-related fouls such as face mask, tripping, illegal blocks below the waist, chop blocks or illegal blind-side blocks
 - (e) late hits by any player after the ball is dead
 - (f) clear pass interference fouls, but only if you see all the action
4. [IN xx0/xx1 FORMATION (CREW OF 4/5/6C) OR IN A GOAL LINE SITUATION] Knowing whether or not a forward pass first touches anything in or behind the neutral zone, and giving the ball touched signal [S11] if it happens. *The wing officials may be able to assist you with this.*[§]
5. Advising the Referee if the pass was thrown into an area not occupied by an eligible receiver, or the pass clearly did not reach the neutral zone.

Once the pass is complete, apply the same priorities as on a running play (above).

10.4.b – Response to what happens (movement and signals)

1. Move towards the line of scrimmage.
 - (a) [IN xx0/xx1 FORMATION (CREW OF 4/5/6C) OR IN A GOAL LINE SITUATION] Move quickly all the way up to the line of scrimmage. Except on quick passes or when you are obstructed by players, you should be on the line of scrimmage before the pass is thrown.
 - (b) [IN xx2/xx3 FORMATION (CREW OF 6D/7/8) AND NOT IN A GOAL LINE SITUATION] Move some way towards the line of scrimmage, but it is not essential for you to get all the way there.
 - (c) This movement removes you as a target, opens up your area for shallow passes and allows you to observe *ineligible receivers*² illegally downfield.
2. When the ball is thrown, turn and observe the end of the pass. Signal incomplete pass [S10] if you see the ball touch the ground before the receiver has control of it.
3. If there is a run after the catch, respond as you would on a running play (above).

10.4.c – Advanced techniques

1. Once the pass is thrown, your number one priority is to see the end of the pass. There is no further need to watch the pass blocking: the Referee (or Centre Judge) will hopefully spot any personal fouls. Holding in the backfield after the pass is thrown does not normally affect the play.
2. If the pass is incomplete in your area:
 - (a) If there is no eligible receiver in the area, and/or the pass clearly does not reach the neutral zone, move quickly towards the Referee to inform them of this. If the ball crossed the neutral zone, give signal [Sup42] by pointing to the ground beyond the neutral zone. If the ball did not cross the neutral zone, move towards the Referee while pointing to the ground behind the neutral zone.
 - (b) If there *is* a receiver in the area, and you believe the Referee may not be aware of that fact, move towards the Referee while pointing towards the eligible receiver. Calling out "Number 34 was in the area of the pass" (for example) is also permissible.
 - (c) [USING O2O/CREW RADIO] Transmitting this information is also an option.

3. If you observe the pass being tipped, give the ball touched signal [S11]. The signal should normally be used on passes tipped in the offensive backfield, but inconspicuous (to the spectators) touching downfield could be signified in this way too. It is not necessary to give it when the pass is obviously touched (e.g. when a defensive lineman bats it into the ground).
4. If you see the pass caught, move towards the receiver, but give no signal. If unsure, move towards the receiver but look to other officials who may have had a view. If they signal incomplete pass [S10], repeat the signal once to confirm you've seen it.
5. If the **play** ends near to the line to gain, assist the wing official by handing a ball to them at the exact dead-ball spot, so that they can mark it.

10.5 - Goal line plays

10.5.a – Priorities

Same priorities as on other scrimmage plays, plus:

1. Being prepared to assist the wing officials with forward progress, fumbles or goal line penetration if their view is obstructed.
2. Observing fouls such as illegal passes (MOFO 10.4.a.3.b) and knowing whether a forward pass first touches anything in or behind the neutral zone (MOFO 10.4.a.4).

10.5.b – Initial positioning

1. Take a position slightly closer to the neutral zone than normal, providing that you do not get in the way of players. Be careful not to line up on the goal line or obstruct the view of the wing officials.

10.5.c – Response to what happens (movement and signals)

1. On a pass play, move quickly all the way up to the line of scrimmage (MOFO 10.4.b.1.a). Except on quick passes or when you are obstructed by players, you should be on the line of scrimmage before the pass is thrown.
2. If the wing officials' view is obstructed, and you are absolutely sure, you may give an unobtrusive signal to communicate what you saw. Before giving any signal, establish eye contact with the wing officials to ensure that they are not going to give a signal contradictory to yours. Give the touchdown-conditions signal [Sup25] to the appropriate wing official(s) only if you believe all the conditions for a touchdown have been met. Don't try to do the wing officials' job for them.

10.5.d – Advanced techniques

1. It is convention that the Umpire never gives the touchdown signal [S5]. Possible exceptions to this might include:
 - (a) if a wing official falls down, or is otherwise well out of position, and not able to make the call
 - (b) on free kick returns
2. Should any doubt exist about a score, be part of the consultation among members of the crew. It is likely that you have some relevant information to offer.
3. In 3rd and 4th down short yardage situations, treat the line to gain as you would the goal line.

10.6 - Returns

10.6.a – Priorities

1. Observing the ball carrier and action around them while you are the nearest official.
2. Observing any fumble where you are the nearest official or have the best view, and marking the spot with a bean bag.
3. Observing blocks by players in your area of responsibility ahead of and around the ball carrier, particularly:
 - (a) illegal block in the back and holding fouls at the point of attack
 - (b) illegal block below the waist fouls anywhere
 - (c) safety-related fouls such as face mask, tripping, chop blocks or illegal blind-side blocks
 - (d) assisting the runner
 - (e) contacting an opponent with the crown of the helmet or targeting a defenseless opponent above the shoulders
 - (f) late hits by any player after the ball is dead
4. Observing any *legal*[†] hand-off or pass where you are the nearest official or have the best view, and marking the spot with a bean bag.
5. Observing any *illegal* forward pass or forward handing, especially if you have a view that is level or nearly level with the ball carrier.

10.6.b – Response to what happens (movement and signals)

1. Keep out of the players' way.
2. Move towards Team A's goal line keeping out of the way of the play. Allow the ball carrier to pass you but continue to observe action around them.
3. If you are watching a block develop, stay with it before switching to the ball carrier or another block. Even if you expect another official to take responsibility for it, stay with the block until you are confident it is legal.
4. If the ball becomes dead in your area of responsibility, blow your whistle, give the timeout signal [S3], and then signal first down [S8] to show which team is in possession. Hold the signal until you know the Referee has seen it.

10.6.c – Advanced techniques

1. Do not get too close to the play – move away from it if necessary to maintain a safe position on the field.

10.7 - Punts**10.7.a – Priorities**

Before and during the kick, applying the same priorities as on basic scrimmage plays (above), plus:

1. Noting players with numbering exceptions **when the snapper is established and determining the legality of the formation.** Also,[†] during the down, observing whether they go downfield if a legal forward pass crosses the neutral zone.
2. Observing fouls by all players generally in your area, but particularly:
 - (a) **defensive linemen lined up over the snapper or[®]** any action against the snapper that might be roughing
 - (b) before the kick, illegal block in the back and holding fouls by linemen and backs protecting the kicker, especially the tight end and/or wing back on the side opposite the Referee
 - (c) during the kick, illegal block in the back and holding fouls against Team A players trying to get down the field
 - (d) illegal blocks below the waist
 - (e) contacting an opponent with the crown of the helmet or targeting a defenseless opponent above the shoulders
 - (f) safety-related fouls such as face mask, tripping, chop blocks or illegal blind-side blocks
 - (g) unnecessary roughness fouls away from the ball
 - (h) late hits by any player after the ball is dead
 - (i) illegal formation
3. Responding to bad snaps or blocked kicks by adopting run, pass or return priorities, as appropriate.
4. Knowing whether a short kick touches the ground, a player or official beyond the neutral zone.

During a punt return, applying the same priorities as on returns (above).

10.7.b – Initial positioning

1. Take normal scrimmage down position, ensuring that you have a clear view of the snapper.

10.7.c – Response to what happens (movement and signals)

1. Maintain a position where you can watch the initial charge by both teams, blocking by the offense, and action by defensive players.
2. Pay particular attention to actions by and against the snapper and also holding and tripping by the defense which prevents offensive players getting downfield.
3. [IN xx0/xx1 FORMATION (CREW OF 4/5/6C)] On short kicks or kicks that are partially blocked and in front of you, be prepared to rule on any interference with the opportunity to catch, and watch for fair catch signals.
4. Do not turn round to watch a long kick. Stay focused on players in your area.
5. As players start to go past your position, turn and move quickly in the same direction.
6. If the play turns into a run or pass, respond as you would do normally for that type of play.

10.7.d – Advanced techniques

1. Particularly check for the correct number of players on Team A. Teams get mixed up more often on punt plays than any other.
2. If you can, help the Referee determine whether the player who contacted the kicker was also the one who blocked the kick.

10.8 - Field goal & try attempts**10.8.a – Priorities**

Before and during the kick, applying the same priorities as on basic scrimmage plays (above), plus:

1. Noting players with numbering exceptions **when the snapper is established and determining the legality of the formation.** [†] Also, during the down, observing whether they go downfield if a legal forward pass crosses the neutral zone.

2. Observing fouls by all players generally in your area, but particularly:
 - (a) **defensive linemen lined up over the snapper** or[®] any action against the snapper that might be roughing
 - (b) illegal block in the back and holding fouls by linemen and backs protecting the kicker, especially the tight end and/or wing back on the side opposite the Referee or [IN xx3 FORMATION (CREW OF 7/8)] the press box side of the formation
 - (c) defensive players illegally attempting to block the kick (defensive restrictions), **e.g. by using leverage or leaping**[§]
 - (d) illegal blocks below the waist
 - (e) contacting an opponent with the crown of the helmet or targeting a defenseless opponent above the shoulders
 - (f) safety-related fouls such as face mask, tripping, chop blocks or illegal blind-side blocks
 - (g) players meeting opponents with a knee
 - (h) late hits by any player after the ball is dead
 - (i) illegal formation
3. After the ball is kicked, continuing to observe players until they are totally separated. Never turning around to see whether the kick is successful or not, never echoing the success/failure signals made by the official(s) ruling on the kick, never writing down the score, never getting a new ball, never doing anything other than observing the players until there is no possible threat of trouble.
4. Responding to bad snaps or blocked kicks by adopting run, pass or return priorities, as appropriate. During a field goal return, applying the same priorities as on returns (above).

10.8.b – Initial positioning

1. Take normal scrimmage down position, ensuring you have a clear view of the snapper.

10.8.c – Response to what happens (movement and signals)

1. Maintain a position where you can watch the initial charge, check blocking by the offense and action by defensive players.
2. Pay particular attention to actions by and against the snapper.
3. Be vocal to avoid cheap shots.
4. [IN 2x0/2x1 FORMATION (CREW OF 4/5)][‡] Move to the goal line if a run or pass develops to the Line Judge's side of the field and they are not in position there.
5. When the attempt is over, start timing the one-minute intermission to the kickoff (Rule 3-3-8-f).

10.8.d – Advanced techniques

1. Be alert for blocked kicks and their recovery and advance. On fake kicks switch to normal run or pass coverage.
 - (a) If the play turns into a run or pass, respond as you would do normally for that type of play. [×]
 - (b) **Be aware of the jersey numbers of any players with eligible numbers who are in ineligible positions, so that, if a pass develops, you can rule on ineligibles touching a pass or being illegally downfield.** [§]
2. Give the ball touched signal [S11] ONLY if the kick is touched (but not forced touched) by Team B BEYOND the neutral zone.

10.9 - After each down

10.9.a – Priorities

1. Observing dead-ball action by players of both teams.
2. Encouraging the players to unpile safely, and either return the ball to an official or leave it near the dead-ball spot, as appropriate.
3. Checking whether the line to gain has been reached or is close, and signalling appropriately.
4. Checking whether any penalty flags have been thrown, and, if so:
 - (a) Giving the timeout signal [S3].
 - (b) Reporting any fouls you have called to the Referee.
 - (c) Knowing what fouls have been called by any colleagues.
 - (d) Assisting the Referee with penalty enforcement, ensuring that they give appropriate options (where necessary) or **make** an appropriate decision that the option is "obvious".
 - (e) Ensuring that all penalties are enforced correctly.
 - (f) Keeping the wing officials informed of the penalty and its enforcement.
5. Checking for injured players or other occurrences that may delay play.
6. Allowing legitimate requests for timeouts. Checking that a request coming from the coaching box or team area was made by the Head Coach.
7. Timing the duration of a timeout.
8. Echoing all timeout signals [S3] of your colleagues.
9. Assisting in relaying the dead ball or a new ball to the succeeding spot.
10. Spotting the ball at the succeeding spot, or relaying it to the Referee or Centre Judge to spot it there.

11. Noting the lateral placement of the ball using elastic bands or some other device. The system for denoting lateral position is described in paragraph 6.6.10.
12. Standing over the ball if any of the conditions of MOFO 10.9.c.14 apply. [IN 3xx FORMATION (CREW OF 6C/8)] This should primarily be the Centre Judge's responsibility, but you need to do it if they do not.

10.9.b – Initial positioning

1. Shortly after the end of the previous down, you should be in a position where you can observe the dead-ball spot and the action around it. The precise position will depend on what happened on the previous play.

10.9.c – Response to what happens (movement and signals)

1. If you are the Coverer, [give only one signal that the ball is dead](#). See paragraph 6.5.14.⁴
2. If a penalty flag has been thrown follow the procedure in Chapter 19. [If an inadvertent whistle has been blown, follow the procedure in Section 6.15](#).[§] If a team or injury timeout has been called, follow the procedure in Chapter 17. If a period has ended, follow the procedure in Chapter 20.
3. As a play ends, move into position to assist other officials and to observe players in potentially explosive situations.
4. If the play ends in bounds, move rapidly (but with regard to your own safety) towards the dead-ball spot to assist the Coverer.
5. If the play ends out of bounds, move quickly towards the sideline to assist other officials either in supervising players or in obtaining a ball.
6. On an incomplete pass, ensure that all action around the end of the pass is over (move quickly to cover it if necessary), then quickly move to retrieve, relay or spot the ball as appropriate.

Spotting the ball for the next down:

7. Help separate players congregated around the dead-ball spot.
8. Co-ordinate with the other officials to get a ball to the succeeding spot (MOFO 6.7).
9. In hurry-up situations, when the clock is running, go get the ball wherever it is (unless the Referee or Centre Judge is clearly nearer) (MOFO 6.2.10).
10. If there is a penalty that requires options to be given to one or both captains, get the captain(s) and approach the Referee. Listen to the Referee explain the options.
11. While a penalty is being enforced, keep the ball in your hands rather than putting it at the dead-ball spot.
12. If you are spotting the ball:

(a) [Before doing so, quickly check that there are no injured players](#).[®]

(b) Face the Coverer, not the goal line, when spotting the ball. Take the forward progress from the Coverer and place the ball at the succeeding spot. Following an incomplete forward pass, penalty, etc., verify that the lateral placement of the ball is correct.

(c) Place the ball laces down if there is any risk of it rolling away from its position.

Getting ready for the next down:

13. If you spotted the ball, before backing away from it:
 - (a) Set your lateral placement marker (MOFO 6.6.10).
 - (b) Set your down counter.
 - (c) Check that the Line Judge is in position and facing infield.
 - (d) Check that the [Down Judge](#) is in position and facing infield.
 - (e) Check that the down box is at least moving into position and showing the correct down. (It is also a good time to check where the line to gain is and if you need to give signal [Sup6].)
 - (f) Finally, look at the Referee who may be signalling [Sup36] to keep you over the ball.
14. If you spotted the ball, move away from it to your pre-snap position unless:
 - (a) The down box is not yet at or near the succeeding spot.
 - (b) After a stoppage (e.g. change of possession, timeout or change of quarter), the defense is clearly not ready (i.e. not roughly in a formation).
 - (c) Defensive substitutions (in response to Team A substitutions) are still in progress (that ends when the last substitute gets to their place in the formation, or gives up doing so).
 - (d) Other officials are not in or near position for the next down and facing or clearly about to face the ball.
 - (e) In a situation where the Referee must declare the ready for play, they do not look ready to do so. (If they are not but should be, make eye contact and/or say "we're ready".)
15. If the 40-second play clock is already running, step away from the ball [to your position](#).[®] If the 40-second play clock is not running, wait over the ball until the Referee indicates [that you should step away to your position](#).[®]
16. If you did not spot the ball, there is no need to go to stand over it unless there is a problem. However, if there is a problem, move to stand over the ball until it is resolved.
17. [IN 3xx FORMATION (CREW OF 6C/8)] Whether you or the Centre Judge spotted the ball, if someone needs to return to stand over it to prevent play, normally this would be the Centre Judge.
18. If there is a stoppage in play, stand over the ball (facing the offense) until the reason for the stoppage has ended, e.g.:
 - (a) the one minute of the timeout has ended (or both teams are obviously ready);

- (b) the Referee has completed their penalty announcements;
 - (c) the injured player is clear of the field;
 - (d) the chains are back at the sideline after a measurement;
 - (e) any other stoppage in play has ended.
19. If Team A is in or approaching its formation, do not turn your back to the ball in case the play starts while you are not looking.
 20. Make sure you know the status of the game clock and make sure the Referee does too. If the previous play was an incomplete pass, confirm this to the Referee in case they did not see the outcome of the play.
 21. There is no need to stand holding the ball to keep it dry in wet or muddy conditions. Placing it with the lace down hill or down wind should normally be enough to prevent it blowing or rolling away.
 22. Verify that players' equipment complies with the rules. Visually check players entering the game.

10.9.d – Advanced techniques

1. The priority at the end of a play is to get into position ready for the next one. Only if a serious incident occurs (such as a foul or misconduct, an injury, or a breakage of the chain) should your routine be interrupted.
2. [IN 2xx FORMATION (NO C)] If Team A makes substitutions **while the snapper is at, near or moving towards** their position at the line of scrimmage:
 - (a) Any official should be prepared to step in and shut down a play that violates the substitution rule.
 - (b) **Anticipate that the Referee may give the matching substitutes signal [Sup36] by moving to a position where you can get to the ball before the snapper can.** [◇]
 - (c) **If the Referee gives the matching substitutes signal (or forgets to do so when Team B is responding to Team A substitutes),[◇] take a position over the ball to prevent Team A from snapping it until Team B has had an opportunity to place its substitutes into position and its replaced players have left the field of play.**
 - (d) While standing over the ball, plan the route you will take to get away from the players before the ball is snapped.
 - (e) When Team B has completed its substitutions (or does not make any), inform the snapper/QB not to snap the ball until they receive verbal approval from you. If they snap the ball before they are given verbal approval, Team A will be assessed a Delay of Game foul after a warning for the first offence (MOFO 3.4.1.f). **(Warn for first offence and penalise second and subsequent.)** ^λ
3. [IN 2xx FORMATION (NO C)] If Team A attempts a hurry-up play, leave the ball as soon as you have spotted it, unless there is a matching substitutes situation (MOFO 6.2.10).
4. [IN 3xx FORMATION (CREW OF 6C/8)] Remain in your normal position unless the Centre Judge does not react, in which case do as you would on a smaller crew.
5. If the Referee does not signal the ready for play when they should do so, remind them immediately.
6. If the Referee declares the ball ready for play while Team A is at the line of scrimmage and you are still standing over it, remind them discretely to give you time to get into your proper position before they do so.
7. [IN xx0 FORMATION (CREW OF 4)] If there are stadium game and/or play clocks, check to see that they have started correctly.
8. **Procedures intended to allow the defense to match up must not be used for a substitution for a last-second field goal. In that situation, Team A is making a normal and expected personnel change and Team B should be prepared to respond appropriately. In no case should an official be standing over the ball to prevent the snap as the clock runs out.** [§]
9. If you want to speak to a player on the field (e.g. to warn them that they are close to fouling), it often saves time to relay the message via the Referee or Centre Judge (for a Team A player). Don't delay the game unnecessarily by entering either team's huddle, unless a timeout is still in progress. Never attempt to speak to a player during a hurry-up or no-huddle offense.
10. Maintain your concentration, and think about the next play.

11. DOWN JUDGE AND LINE JUDGE (CREW OF 4/5/6C)

11.1 - Free kicks

11.1.a – Priorities

Prior to the kick:

1. Being aware of whether the Referee has instructed the crew to switch to onside-kick positions, and moving position (if appropriate) if they have.
2. [LINE JUDGE] and [IN F6 FORMATION (CREW OF 6)] [DOWN JUDGE] Counting Team B players and signalling the count [one of Sup3, Sup4 or Sup24] to colleagues. Noting count signals from colleagues. Recounting if your count differs from that of colleagues.
3. [IN F4-5 FORMATION (CREW OF 4/5)] [DOWN JUDGE] Counting Team A players and signalling the count [one of Sup3, Sup4 or Sup24] to colleagues. Noting count signals from colleagues. Recounting if your count differs from that of colleagues.
4. Reminding the players to count their number if the team you are responsible for counting does not have precisely **the correct number of**² players on the field.
5. Checking readiness for play:
 - (a) Checking side and end zone areas to ensure that all non-players are out of the restricted areas, that non-participants are off the field of play, **that the safety zone is clear,**[®] and that all team personnel are within the team area.
 - (b) Ensuring that the chain crew (and the alternate down box and line-to-gain marker operators, where provided) have moved themselves and their equipment well out of the way and that the equipment has been placed on the ground outside the team areas and **outside the safety zone**[®] at the receiving team's end of the field. Checking that the ball persons are in position.
 - (c) If you are positioned on a restraining line, ensuring that all Team A players **have been within the nine-yard marks after the ready for play and prior to the kick,**[‡] (Rule 6-1-2-c-5) and that nobody other than the kicker is more than five yards behind the ball.
 - (d) Facing the field of play to signal that you are ready. Turning away, **or obviously leaving your position,**[°] if something on your sideline becomes no longer clear or you can see that a colleague is clearly not ready. Sounding your whistle, if your area becomes dangerously unclear after the ready for play.
6. Being alert always for short kicks.

During the kick play:

7. Observing whether a free kick goes out of bounds nearest to you without being touched by the receiving team. Ruling whether a Team B player near the sideline touches the ball while out of bounds.
8. Watching players for a fair catch signal, and being prepared to rule on any interference with the opportunity to catch the kick.
9. If[×] the kick is short:
 - (a) Knowing where and by whom the ball was first touched.
 - (b) If you are positioned on Team B's restraining line, knowing whether the kick breaks the plane of that line.
 - (c) Observing illegal blocks by Team A (Rule 6-1-12).
 - (d) Marking any spot of illegal touching with a bean bag.
 - (e) Marking the dead-ball spot if you are the nearest official and there is little or no return run.
10. Giving the start the clock signal [S2] only if the ball is first legally touched in the field of play **and you are the nearest official or you have the best view of it.**
11. [LINE JUDGE] and [IN F6 FORMATION (CREW OF 6)] [DOWN JUDGE]
 - (a) Ruling whether the ball becomes dead in the end zone or not.
 - (b) Marking the forward progress or out of bounds spot if the ball becomes dead on your side of the field. This responsibility extends up to Team A's 2-yard line.
 - (c) Marking the spot with a bean bag of any backward pass, handing or fumble in your area.
12. [IN F4-5 FORMATION (CREW OF 4/5)] [DOWN JUDGE]
 - (a) Marking the dead-ball spot if you are the nearest official when the ball carrier is tackled or goes out of bounds.
 - (b) Ruling a touchdown at Team A's goal line.
13. Observing fouls/violations by all players generally in your area, but particularly:
 - (a) illegal touching of a short kick
 - (b) infractions of your restraining line [LINE JUDGE] (when in onside-kick positions only)
 - (c) illegal blocks in the back and holding fouls at the point of attack
 - (d) illegal blocks below the waist
 - (e) contacting an opponent with the crown of the helmet or targeting a defenseless opponent above the shoulders

- (f) safety-related fouls such as face mask, tripping, chop blocks, illegal wedges or illegal blind-side blocks
- (g) late hits by any player after the ball is dead
- (h) any player of the kicking team who enters the field of play after the kick or who voluntarily goes out of bounds during the kick and returns inbounds
- (i) [illegal forward handing or illegal forward passes](#)

11.1.b – Initial positioning

Normal kicks:

1. If the free kick takes place after a score, proceed along the sideline to your kickoff position, ensuring as you do so that the team on your side of the field is aware of the progress of the one-minute intermission (Rule 3-3-8-f).
2. [LINE JUDGE] Be in position B (see 26.1) [slightly behind](#)[◊] Team B's goal line outside the sideline on the press box side of the field. Stand where you can see in a straight line over the pylon towards where the kick will come from.
3. [DOWN JUDGE]
 - (a) [IN F4-5 FORMATION (CREW OF 4/5)] Be in position E (see 26.1) outside the sideline opposite the press box on Team B's restraining line.
 - (b) [IN F6 FORMATION (CREW OF 6)] Be in position C (see 26.1) [slightly behind](#)[◊] Team B's goal line outside the sideline opposite the press box side of the field. Stand where you can see in a straight line over the pylon towards where the kick will come from.

Onside-kicks:

4. [DOWN JUDGE]
 - (a) [IN F4-5 FORMATION (CREW OF 4/5)] Remain in the normal position.
 - (b) [IN F6 FORMATION (CREW OF 6)] Move to position E (see 26.1) outside the sideline opposite the press box on Team B's restraining line.
5. [LINE JUDGE]
 - (a) [IN F4 FORMATION (CREW OF 4)] Move to position F (see 26.1) outside the press box sideline on Team A's restraining line.
 - (b) [IN F5-6 FORMATION (CREW OF 5/6)] Move to position D (see 26.1) outside the press box sideline on Team B's restraining line.

Free kicks after a penalty or safety:

6. When a free kick is taken following a penalty or a safety, the same relative positions should be taken, moving up or down the field as appropriate.

11.1.c – Response to what happens (movement and signals)

Prior to the kick:

1. If anything happens that should prevent the kick taking place (e.g. a non-player enters or approaches the field of play), toot your whistle, give the timeout signal [S3] and deal with the problem.

During any kick play:

2. If you see any player of the kicking team voluntarily go out of bounds during the kick, drop your bean bag or hat to mark their exit, and your flag if they return.
3. If the clock should start when the ball is first legally touched in the field of play, give the start the clock signal [S2] if you are the nearest official or the one with the best view.

During a kick play that goes deep:

4. After the ball is kicked, observe the players in your area of responsibility (see 26.1). After checking its initial trajectory, do not watch the flight of the ball.
5. [LINE JUDGE] and [IN F6 FORMATION (CREW OF 6)] [DOWN JUDGE]
 - (a) If the kick threatens to go into the end zone, [step up to the goal line extended](#)[◊] (out of the way of all players) to rule on a touchback. If the ball threatens the pylon, be there to be able to rule on whether the ball goes out of bounds in the field of play or the end zone.
 - (b) If the live ball and at least one player go deep into the end zone, move to cover the end line.
 - (c) If a touchback occurs:
 - (i) Sound your whistle loudly to prevent further action.
 - (ii) Move infield ahead of any receiver who has the ball. Until you get in front of them, continue to watch them in case they are fouled.
 - (iii) Give the touchback signal [S7].
 - (d) On a deep kickoff, follow the ball carrier and keep them [boxed in](#)² between you and the upfield officials.
6. [IN F4-5 FORMATION (CREW OF 4/5)] [DOWN JUDGE] Move downfield along the sideline while the kick is in the air. During the return, stay ahead of the ball carrier, keeping them [boxed in](#)² between you and the downfield official. On a long run, be at Team A's goal line before the ball carrier. [You have shared responsibility for the goal line.](#)[◊] Mark the dead-ball spot if you are the nearest official when the ball carrier is tackled or is out of bounds.
7. If the ball goes out of bounds in your area, go to and hold the spot, dropping your flag if appropriate.

During a kick play where the kick is short:

8. Maintain a position where you can see the ball and the blocks by Team A players.
9. [IF ON TEAM A'S RESTRAINING LINE] Particularly **observe**² the blocks made by Team A players before they are eligible to touch the ball (Rule 6-1-12).
10. [IF ON TEAM B'S RESTRAINING LINE] Know where and by whom the ball was first touched. Mark any spot of illegal touching with your bean bag (Rule 6-1-3).
11. If you are the nearest official when the ball becomes dead, signal timeout [S3] and mark the dead-ball spot.

11.1.d – Advanced techniques

1. [IF ON TEAM B'S GOAL LINE] You may adjust your position according to such factors as the free kick spot, the wind and the known strength of the kicker's foot. However, it is important to be on the goal line (and particularly, at the pylon) before the ball gets there in crucial situations. **If the ball threatens the pylon, be in line with the kick so that you can rule whether the ball crosses the goal line or the sideline first.** §
2. **After the ball is dead and all action is ceased, if you are the nearest official to the previous spot make sure that any kicking tee has been removed from the field.** ◊

11.2 - Basic scrimmage plays**11.2.a – Priorities**

1. Knowing the down and distance, and signalling the down to your colleagues. Noting the down signals given by colleagues. Checking that the down box displays the correct number. Not allowing play to start if there is a dispute about the down number.
2. Counting Team B players and signalling the count [one of Sup3, Sup4 or Sup24] to your colleagues. Noting count signals from colleagues. Recounting if your count differs from that of colleagues.
3. Observing false starts in general and, in particular, by linemen and backs on your side of the formation. **This includes when Team A never sets.**
4. **Observing other illegal shifts (no 1-second pause after simultaneous movement by Team A players).** ◊
5. Observing offside (and other line of scrimmage infractions) by Team B players (especially those between you and the ball).
6. Observing illegal motion by Team A players on your side of the formation.
7. Observing the legality of the snap.
8. If there is a pre-snap foul, stopping all action by tooting on your whistle and giving the timeout signal [S3].
9. Anticipating whether the play is a run or a pass by reading the initial action of the interior linemen. If they move backwards it is likely that a pass play will develop. If they charge forwards or pull, it is likely that a running play will develop.
10. Identifying your key player(s) (see sections 16.3 and 16.4). If the formation is new or unusual, verbally or visually confirming this with the other officials.
11. Noting eligible receivers and those players who would normally be eligible by position but who are ineligible by number. In addition, noting players (usually tight ends) who would normally be eligible by number but who are not eligible because a player is lined up outside them on the line of scrimmage.
12. Being aware of where the line to gain is in relation to the line of scrimmage so that you don't have to look at the chain to know if the dead-ball spot is close to the line to gain.
13. Observing substitution infractions by both teams (especially the team on your side of the field). For example:
 - (a) replaced players not leaving the huddle within 3 seconds of an incoming substitute entering it
 - (b) replaced players not being off the field before the snap
 - (c) substitutes coming on to the field, communicating, and then leaving the field
14. Ensuring that coaches and substitutes are behind the coaching box line and that your sideline is clear of any obstructions.
15. **[DOWN JUDGE]** Noting whether the chains and down box are in their proper position, but only preventing play if there is a serious problem.
16. Observing the legality of the formation, in particular that there are no more than 4 players in the backfield.
17. **Alerting colleagues if Team A makes a substitution while the snapper is at, near or moving towards their position at the line of scrimmage.** §
18. Indicating Team A's scrimmage line (the tail of the ball) using your foot that is nearest their goal line.
19. **Until the ball is snapped,** § indicating, using the off-the-line signal [Sup1], when the Team A player closest to you is off the line of scrimmage.
20. Observing whether all Team A players have met the requirement for being within the nine-yard marks.
21. **[DOWN JUDGE]** If the distance to the line to gain is approximately 5 yards, know whether a 5-yard penalty would give a first down or not.

11.2.b – Initial positioning

1. Be where you can see the entire neutral zone, and the ball at the snap.
2. Normal scrimmage down position is in the neutral zone, **at least one yard outside the sideline.** †

3. [DOWN JUDGE] Be on the side of the field opposite the press box.
4. [LINE JUDGE] Be on the press box side of the field.
5. Never adopt a position that restricts the positioning or movement of players.
6. Never speak to players or coaches when the snap is imminent.

11.2.c – Response to what happens (movement and signals)

1. In the event of sudden movement by Team A players, come in quickly and confer with the Umpire to determine which team was responsible.
2. If one or more Team B players enter the neutral zone, watch the reaction by Team A players who may be threatened. Watch for when the Team B players get back to their own side of the neutral zone.
3. If there is a foul before the snap, blow your whistle, throw your flag and signal timeout [S3]. Come in quickly to the succeeding spot to prevent any play and to confer with the Umpire and the other wing official about the call. However, if there is no possibility of doubt about what the foul is, you may give a miniature penalty signal [e.g. S18 or S19] to the Referee without coming in all the way or [USING O2O/CREW RADIO] transmit the foul to all colleagues. @

11.2.d – Advanced techniques

Reasons for varying (or not) your initial position:

1. You get a much better view of everything from a wide position. It also prevents you being caught inside on a sweep play or out-pattern pass. x
2. If a Team A player asks you whether they are on or off the line of scrimmage, inform them how they can use your signals to tell for themselves. Do not say anything to the player that might cause them to move immediately prior to the snap. Do not answer questions like "Am I on/off the line?" with a yes/no response, since you may have misheard the question. The fact that you are indicating the line with your foot and not using the off-the-line signal [Sup1] is sufficient to indicate to all concerned that the player nearest you is *on* the line. No separate signal is necessary or desirable.
3. If there is more than one receiver close to you off the line, you may optionally show the number by outstretching fingers at the end of your off-the-line signal [Sup1].
4. Do not attempt to give the off-the-line signal [Sup1] and a Team B player count signal [either Sup3 or Sup24] at the same time. Two outstretched arms may be misinterpreted as the matching substitutes signal [Sup36]. @

Signalling the player count:

5. The latest time to make the player count signal is when the offensive team breaks its huddle (but it can and should be done earlier if possible).
6. Normally the player count signal is shared between the Down Judge, Line Judge and [IN xx1 FORMATION (CREW OF 5/6C)] the Back Judge.

11.3 - Running plays

11.3.a – Priorities

1. Observing the ball carrier and action around them.
2. Blowing your whistle and marking the forward progress or out of bounds spot if the ball becomes dead in the middle or on your side of the field. If the ball goes to the other side of the field, backing up your colleague on the other side of the field by either estimating the dead-ball spot or mirroring their spot.
3. Observing any fumble where you are the nearest official or have the best view, and marking the spot with a bean bag.
4. Observing fouls by all players generally in your area, but particularly:
 - (a) illegal block in the back and holding fouls at the point of attack, especially those made by a wide receiver, tight end, lead back or pulling lineman
 - (b) illegal block below the waist fouls by players on your side of the formation
 - (c) safety-related fouls such as face mask, tripping, chop blocks or illegal blind-side blocks
 - (d) late hits by any player after the ball is dead
 - (e) unnecessary roughness against the quarterback after they have handed off or pitched the ball on a play away from you
5. Ruling (with help from the Referee or Centre Judge on passes from deep in the backfield) whether a pass is backward or forward, and signalling a backward pass [Sup5] immediately if the pass is clearly backward. Noting any backward pass signal from the Referee or Centre Judge. Not attempting⁴ to make a pass/fumble ruling if the passer is contacted — leave that to the Referee or Centre Judge. §

11.3.b – Response to what happens (movement and signals)

1. If the run comes to your side of the field:
 - (a) Retreat at an angle out of bounds and towards Team A's end line if necessary.
 - (b) Pick up coverage of the ball carrier as they approach the neutral zone in your area.
 - (c) Let the ball carrier get ahead of you, then follow them downfield until the ball becomes dead, keeping out of the way of all players.

- (d) Once the ball becomes dead, blow your whistle and move to a point level with the forward progress spot.
 - (e) If the ball becomes dead inbounds and near the sideline, be prepared to take forward progress from your wing colleague using cross-field mechanics if the ball carrier is driven back towards you.
2. If the run goes up the middle:
 - (a) Stay wide but approximately level with the ball carrier's progress.
 - (b) Come in when the play is dead to rule on forward progress. Come in until you meet resistance (do not leap over players). **Exception:** Don't come in if Team A is in a hurry-up offense (or should be) and the clock is still running.
 - (c) Only blow the whistle if you can clearly see the ball and the player in possession.
 3. If the run goes to the opposite side of the field:
 - (a) Stay wide but approximately level with the ball carrier's progress.
 - (b) Keep your eyes open for cheap shots behind the play.
 - (c) Stay focused – be alert for reverses.
 - (d) When the ball becomes dead, move level with the dead-ball spot. Do not blow your whistle.
 - (e) If your colleague on the opposite side of the field is unable to get to the dead-ball spot quickly (e.g. because the ball becomes dead close to the sideline or the ball carrier is driven back):
 - (i) Assist them by staying in position level with your best judgement of the forward progress spot (cross-field mechanics), but do not be obtrusive about this.
 - (ii) Hold this position long enough to allow them an opportunity to mirror your spot if they are unable to judge it themselves, but give it up when the Coverer obviously indicates a forward progress spot of their own.
 - (iii) If the Coverer marks a very inaccurate spot, unobtrusively attract their attention to your spot. [\[USING O2O/CREW RADIO\] is one way of doing this, particularly if they are looking away from you \(MOFO 25.5.1\).](#) §
 4. On a long run:
 - (a) Follow the play, maintaining as good a view as possible of the ball carrier and the players near them. Be prepared to close in when the ball becomes dead and mark the forward progress spot.
 5. If the run ends behind the line of scrimmage:
 - (a) Assist the Referee (or Centre Judge) in determining forward progress.
 6. Remain out of bounds until you are certain the ball is becoming dead. Never turn your back on the ball.

Covering the dead-ball spot:

7. When marking forward progress, converge to the dead-ball spot when play in your area permits. Square off, i.e. move parallel to the sideline then in, rather than diagonally. This is particularly important on pivotal plays that end around the line to gain or goal line, where *selling* the spot may be crucial (MOFO 5.7).
8. Be alert to cover the forward progress spot when the ball carrier has been driven back, but watch the ball carrier (and action against them), not the spot. Do not leap over or pass players to reach the forward progress spot: keep them in front of you. Drop your bean bag *only* if you are forced to leave your spot.
9. If the ball goes out of bounds on your side of the field, signal timeout [S3]. Move to the dead-ball spot once players have cleared the immediate area. Stop on the sideline and watch any continuing action in the out-of-bounds area.
10. If absolutely necessary, mark the dead-ball spot with your bean bag and go out-of-bounds to prevent/stop continuing action.
11. Once all action has ceased, help (if needed) to retrieve/relay another ball to the Spotter (MOFO 6.7).
12. If the ball becomes dead within approximately 10 feet of the sideline and the clock should not stop for any other reason, give the wind the clock signal [S2].

11.3.c – Advanced techniques

1. Don't blow your whistle when the ball carrier's back is toward you or you are obscured by other players [or officials](#)² – they may have fumbled the ball without you seeing it. See leather! Be certain that the ball is dead.
2. If a pile-up of players forms, give the timeout signal [S3], converge on the pile, determine who has possession (MOFO 6.10) and encourage players to unpile safely.
3. If you're not the nearest official to the dead-ball spot, observe for late hits and other illegal acts.

Particular types of run play:

4. On a pitchout option play to your side of the field:
 - (a) Move into the backfield to observe action against the trailing back (any offensive player in a position to receive a backward pass), until the ball is pitched or the quarterback turns upfield.
 - (b) If the ball is pitched, you are responsible for the loose ball and for action by and against the trailing back.
 - (c) If the ball is not pitched, once the quarterback turns upfield they are your responsibility as on any other running play, and the Referee (or Centre Judge) will take over responsibility for the trailing back.

General tips:

5. It is better to pick up the ball carrier too soon than not soon enough. You may be forgiven for missing a hold, but you will never be forgiven for missing a fumble.
6. Even though the ball may be on the other side of the field, you may have a better view of the end of the run than the nearest official. If the ball carrier is facing you, or has the ball in the hand nearest you, or is spun round towards you in the tackle, you may need to help out your colleague.
7. If you are the Coverer and the run ends near to the line to gain, you must come in all the way and place a ball at the *exact* dead-ball spot.

11.4 - Pass plays**11.4.a – Priorities**

1. Ruling whether the pass is complete or incomplete. While primarily this will be for passes to your side of the field, in practice you may need to rule on any pass where the receiver is facing or at right angles to you, regardless of their position. Similarly, if the receiver has their back to you, you may need to defer to another official with a better view than you.
 2. Ruling on touchdowns on passes into the end zone.
 3. Observing the initial contact by and against your key player(s).
 4. Observing fouls by all players generally in your area, but particularly:
 - (a) defensive and offensive pass interference
 - (b) defensive holding and illegal use of hands against eligible receivers
 - (c) illegal block below the waist fouls by players on your side of the formation
 - (d) illegal touching of a forward pass by a player who went out of bounds voluntarily
 - (e) ineligible receivers downfield
 - (f) **illegal passes**
 - (g) contacting an opponent with the crown of the helmet or targeting a defenseless opponent above the shoulders
 - (h) safety-related fouls such as face mask, tripping, chop blocks or illegal blind-side blocks
 - (i) late hits by any player after the ball is dead
 5. Ruling whether a *quick* quarterback pass went forward or backward. Use the backward pass signal [Sup5] immediately if the pass is backward. Do not attempt to make a pass/fumble ruling if the passer is contacted – leave that to the Referee or Centre Judge. §
 6. **Assisting the Umpire in determining whether a forward pass crossed the neutral zone, particularly on passes thrown to the other side of the field from you.** §
 7. Advising the Referee if the pass was thrown into an area not occupied by an eligible receiver, or the pass clearly did not reach the neutral zone.
 8. Watching for players who go out of bounds across the sideline or end line.
- Once the pass is complete, apply the same priorities as on a running play (above).

11.4.b – Response to what happens (movement and signals)

1. Your progression on a pass play is: (phase A) your key player; (phase B) your zone; (phase C) the destination of the pass. See also Chapter 16.
2. Remain on the line of scrimmage to be able to see all action on your side of the field, and to reduce the possibility that a run or pass leaves you ahead of the ball. Remain there until you are confident a pass is **going to be**⁶ thrown that will definitely cross the neutral zone, then move downfield (typically sidestepping for a short pass; if necessary turning to sprint for a long pass) to get into position to observe the likely destination of the pass, but **(importantly)**² without getting ahead of the intended receiver.
3. Only watch your key player during the initial action after the snap when there is a threat of illegal contact between receiver and defender. Switch to zone coverage as soon as that threat no longer exists.
4. If a potential Team A receiver voluntarily goes out of bounds in your area, drop your bean bag or hat to indicate this, and observe them to see whether they touch a forward pass while still ineligible.
5. Once you are aware that the pass has been thrown, move into position to best be able to rule on whether the pass is complete or incomplete, and whether there is interference. While the ball is in flight, watch opposing players who are contesting for the ball, not the ball itself. Be alert to both offensive and defensive pass interference.
6. If the player who attempts to catch the ball has their back to you, before making the call, look for help from any official in a better position than you.
7. If the receiver is driven back, be prepared to give them their forward progress. This is especially the case when the receiver is near a sideline, and you may need to use cross-field mechanics. If the receiver is on your side of the field, the other wing official may have the best forward progress. Take your spot from them. If the receiver is on the other side of the field, you may have the best spot. Offer a spot to your colleague. **[USING O2O/CREW RADIO] is one way of doing this, particularly if they are looking away from you (MOFO 25.5.1).** §
8. If you are not the nearest official, don't just watch the receiver, but particularly watch for defenders slightly away from the ball who come in and target the receiver with the crown of their helmet or above the shoulders. This is often missed by the nearest official.

9. If the pass is overthrown, bounces off a player or is otherwise uncatchable, continue to watch the player(s) for personal fouls (hitting a defenseless receiver). Do not ball-watch.
10. Blow your whistle if you see the ball become dead in your area.
11. If the pass is thrown to the opposite side of the field from you, your first responsibility is to clean up action on your side of the field and in the middle of the field. However if you are 100% sure of what you see over there, you may assist with rulings on complete/incomplete, pass interference, illegal helmet contact and forward progress.
12. When ruling on pass receptions involving the sideline, give only one signal **after the ball is dead**.[◊] Give the incomplete pass signal [S10] if **you or another official rules the pass**² incomplete. Give the timeout signal [S3] if the pass is ruled complete and the ball carrier goes out of bounds thereafter (MOFO 6.8) or the ball is dead at or beyond the line to gain. Give the start the clock signal [S2] if the pass is complete and **you declare the ball carrier down inbounds**⁴ short of the line to gain **within approximately 10 feet of the sideline**.[§] Whichever signal is used, **give it**² two or three times to maximise the chances of other officials seeing it.
13. When contact that would have been pass interference occurs on a pass that is uncatchable, give the uncatchable pass signal [S17].
14. After an incompletion, obtain a ball from the ball person and form a relay to return the ball to the Spotter (MOFO 6.7).
15. If there is a run after the catch, respond as you would on a running play (above).
16. Maintain a position where you can see player activity in fringe areas, particularly on wide-open plays.

11.4.c – Advanced techniques

1. When an airborne player attempts to catch a pass near the sideline or end line, watch their feet first to see whether they come down in bounds. If they do, then look to their hands to see whether they have control of the ball. If you look at their hands first, you may miss the instant when their foot touches the ground (MOFO 5.4.8).
2. Always be prepared to come back to rule on play near the neutral zone in addition to sideline action. If the potential passer decides to run with the ball, you must cover them (from a downfield position if necessary) once they are beyond the neutral zone.
3. If the pass is incomplete in your area:
 - (a) If there is no eligible receiver in the area, and/or the pass clearly does not reach the neutral zone, move quickly towards the Referee to inform them of this. If the ball crossed the neutral zone, give signal [Sup42] by pointing to the ground beyond the neutral zone. If the ball did not cross the neutral zone, move towards the Referee while pointing to the ground behind the neutral zone.
 - (b) If there *is* a receiver in the area, and you believe the Referee may not be aware of that fact, move towards the Referee while pointing towards the eligible receiver. Calling out "Number 34 was in the area of the pass" (for example) is also permissible.
 - (c) [USING O2O/CREW RADIO] Transmitting this information is also an option.
4. If you observe the pass being tipped, give the ball touched signal [S11]. The signal should normally be used on passes tipped in the offensive backfield, but inconspicuous (to the spectators) touching downfield could be signified in this way too. It is not necessary to give it when the pass is obviously touched (e.g. when a defensive lineman bats it into the ground).
5. If the play ends near to the line to gain, you must come in all the way and place a ball at the *exact* dead-ball spot.

11.5 - Goal line plays

11.5.a – Priorities

Same priorities as on other scrimmage plays, plus:

1. [AT TEAM B'S GOAL LINE] Ruling whether a touchdown is scored or not.
2. [AT TEAM A'S GOAL LINE] Ruling whether a safety is scored or not.
3. Observing players' celebrations after a score.

11.5.b – Initial positioning

1. Take normal scrimmage down position **2 yards out of bounds or wider**[†] so that you will not be trapped by a quick wide play.[×]
2. You have primary responsibility for Team B's goal line if the ball is snapped from on or inside Team B's 7-yard line.
3. You have primary responsibility for Team A's goal line if the ball is snapped from on or inside Team A's 5-yard line.

11.5.c – Response to what happens (movement and signals)

1. If you have responsibility for either team's goal line, *immediately* after the snap, move directly towards it to rule on the score or an accurate forward progress.

[AT TEAM B'S GOAL LINE]

2. On a running play, you must be at the goal line before the ball carrier to rule on whether the ball penetrates the plane. Do *not* move towards Team A's backfield to let players pass you.

3. If you see the ball carrier is stopped short of the goal line, blow your whistle, come in and sell the dead-ball spot. If appropriate, call out "short" to tell your colleagues that.
4. On a pass play, move immediately to the goal line then respond to the play. If the pass is thrown short of the goal line, remain on the line to rule on penetration of the plane. If the pass is thrown into the end zone, move to the best position to rule on the end of the pass. If the ball is thrown to the back of the end zone, be prepared also to rule on plays near the end line.
5. Indicate a score by blowing your whistle and giving the touchdown signal [S5] only when you clearly see the ball break the plane of the goal line in player possession or if you see a pass completed in the end zone.

[AT TEAM A'S GOAL LINE]

6. [SNAP FROM ON OR INSIDE TEAM A'S FIVE-YARD LINE] Be prepared to move back to the goal line to rule on a possible safety. **Assist the Referee (and/or Centre Judge) if Team A's goal line pylon is threatened on your side of the field.** §
7. Indicate a safety by blowing your whistle and giving the safety signal [S6] only when you clearly see the ball carrier down or out of bounds behind the goal line.

[AT EITHER GOAL LINE]

8. If a pile-up forms at the goal line, come into the field of play until you can see the ball. If you are the nearest official, you may need to dig for it. Check with other officials that they did not see the ball carrier down (or fumble the ball) before **the ball²** reached the goal line.
9. If you have goal line responsibility and it is necessary to move out of the players' way as they come towards you, move wider without leaving the goal line.
10. Do not give a score signal if you have thrown a penalty flag for a foul by the scoring team. Do not blow your whistle or give any signal if you are not sure about the outcome of the play.
11. If you have goal line responsibility, straddle the goal line – don't run after the player into the end zone unless there is a threat of trouble by or against them, but do turn to keep your eyes on them to observe late hits or unsportsmanlike conduct.
12. If another official has sideline responsibility, do not signal touchdown until you have confirmed with them that the ball carrier was not out of bounds.
13. Maintain the touchdown or safety signal until you know the Referee has seen it, but keep your eyes on the players – don't look to the Referee until all action has ceased. Don't run and signal at the same time. You should not echo the signals of other officials unless the Referee cannot see their signal.
14. It is especially important on goal line plays that all covering officials indicate the same point of forward progress. Communicate if in doubt. Signal only if sure.

11.5.d – Advanced techniques

1. [IN xx1 FORMATION (CREW OF 5/6C)] [LINE JUDGE] Inform the Back Judge of the number of the yard line that is the line of scrimmage. Communicate (preferably verbally) as to who has the responsibility for the goal line. In noisy situations, point at the line you have responsibility for.
2. In 3rd and 4th down short yardage situations, treat the line to gain as you would the goal line. **On 3rd down, be prepared to move directly to the line to gain if it is less than 3 yards from the previous spot. Unless a kick is likely, on 4th down, be prepared to move directly to the line to gain if it is less than 4 yards from the previous spot.** †
3. If the line to gain is near the goal line, your first priority is the goal line. If necessary come back from the goal line to the line to gain once it is clear that the ball carrier is unlikely to score. Usually, if the ball carrier only looks like getting as far as the line to gain, then that is the place to be. If the ball carrier is running free and looking able to get near the goal line, that is the place to be.
4. [SNAP FROM OUTSIDE TEAM A'S 5-YARD LINE] Decide whether to go back to Team A's goal line or not based on whether the play is to your side of the field and how likely it is that the ball becomes dead near the goal line. (There is little point in going back if there is a low risk of a Team A player being tackled for a safety.)
5. **In "hail mary" situations (i.e. a few seconds to go in either half and Team A will likely throw the ball to the end zone), use goal line mechanics regardless of where on the field the ball is snapped.** §

11.6 - Returns

11.6.a – Priorities

1. Observing the ball carrier and action around them while you are the nearest official.
2. Marking the forward progress or out of bounds spot if the ball becomes dead on your side of the field. If the ball goes to the other side of the field, backing up your colleague on the other side of the field by either estimating the dead-ball spot or mirroring their spot.
3. Observing any fumble where you are the nearest official or have the best view, and marking the spot with a bean bag.
4. Observing blocks by players in your area of responsibility ahead of and around the ball carrier, particularly:
 - (a) illegal block in the back and holding fouls at the point of attack
 - (b) illegal block below the waist fouls anywhere
 - (c) safety-related fouls such as face mask, tripping, chop blocks or illegal blind-side blocks

- (d) assisting the runner
 - (e) contacting an opponent with the crown of the helmet or targeting a defenseless opponent above the shoulders
 - (f) late hits by any player after the ball is dead
5. Observing any *legal*^o hand-off or pass where you are the nearest official or have the best view, and marking the spot with a bean bag.
 6. Observing any *illegal* forward pass or forward handing, especially if you have a view that is level or nearly level with the ball carrier.

11.6.b – Response to what happens (movement and signals)

1. Keep out of the players' way.
2. Move towards Team A's goal line following the play.
3. Observe the ball carrier while they remain in your area of responsibility. Stay wide enough to be able to retreat outside the sideline ahead of the players. Never turn your back on the ball.
4. Assist the Referee on Team A's goal line and (if necessary) end line. You have sideline responsibility to the goal line and end line.
5. If you are watching a block develop, stay with it before switching to the ball carrier or another block. Even if you expect another official to take responsibility for it, stay with the block until you are confident it is legal.
6. If the ball becomes dead in your area of responsibility, blow your whistle, give the timeout signal [S3], and then signal first down [S8] to show which team is in possession. Hold the signal until you know the Referee has seen it.

11.7 - Punts

11.7.a – Priorities

Before and during the kick, applying the same priorities as on basic scrimmage plays (above), plus:

1. [DOWN JUDGE] Ruling whether the kick crosses the neutral zone by knowing if it touches the ground, a player or official beyond the neutral zone.
2. Marking the end of the kick (if inbounds) with a bean bag.
3. Marking the dead-ball spot for any kick that goes out of bounds on your side of the field, however deep.
4. Ruling whether players touched the ball or not.
5. Observing any fair catch signals by players in your area.
6. Observing kick-catch interference against a player in position to catch the kick, if the kick comes down in your area.
7. If the kick does not come down in your area, observing players who have *not* committed kick-catch interference because they were blocked by an opponent into the returner.
8. Marking all spots of illegal touching with a bean bag.
9. Ruling whether a momentum exception applies or not near the goal line.
10. Observing fouls by all players generally in your area, but particularly:
 - (a) illegal blocks below the waist, especially by players on your side of the field and [DOWN JUDGE] the up back
 - (b) during the kick, illegal block in the back and holding fouls against Team A players trying to get down the field
 - (c) a Team A player returning inbounds after voluntarily going out of bounds during the down (*dropping*[^] your bean bag or hat to mark their exit, and your flag if they return)
 - (d) kick catch interference when the kicked ball will land in your area
 - (e) illegal blocks made by players who have signalled for a fair catch
 - (f) contacting an opponent with the crown of the helmet or targeting a defenseless opponent above the shoulders
 - (g) safety-related fouls such as face mask, tripping, chop blocks or illegal blind-side blocks
 - (h) unnecessary roughness fouls away from the ball
 - (i) late hits by any player after the ball is dead
11. Noting the numbers of players in eligible receiver positions on your side of the formation, and observing whether anyone else is the first to touch the ball or is ineligibly downfield if the play develops into a pass play.
12. Responding to bad snaps or blocked kicks by adopting run, pass or return priorities, as appropriate.

During *the* punt return, applying the same priorities as on returns (above).

11.7.b – Initial positioning

1. [IN xx1 FORMATION (CREW OF 5/6C)] Take normal scrimmage down position.
2. [IN xx0 FORMATION (CREW OF 4)] [DOWN JUDGE] Take normal scrimmage down position.
3. [IN xx0 FORMATION (CREW OF 4)] [LINE JUDGE]
 - (a) Adopt the "Judge off" mechanic (211 formation). Be behind and to the side of the deepest returner. Behind so that you can look through them and see the ball kicked. To the side so that you are out of their way, but still close enough to observe whether they touch the ball or not, or whether any opponent

interferes with their opportunity to catch the kick. Remain between the returner and your sideline. About 10 yards away from the returner is an appropriate lateral position, unless you are at or near the goal line, in which case be at your goal line pylon.

- (b) If there is more than one returner deep, take position between your sideline and the nearer of them, keeping well outside the nearest returner until it is clear that returner will not handle the ball.
 - (c) Be prepared to adjust your position according to the strength and direction of the wind, and the ability of the kicker. Move closer to the sideline where the wind is likely to carry the kicked ball.
 - (d) Have a bean bag readily available and a second one to hand.
4. [IN xx0 FORMATION (CREW OF 4)] The Line Judge is responsible for all deep returners.
 5. [IN xx1 FORMATION (CREW OF 5/6C)] The Back Judge will have responsibility for the end of the kick, unless it ends very close to a sideline or the Back Judge is well out of position,[§] in which case it is the responsibility of the nearest sideline official.

11.7.c – Response to what happens (movement and signals)

1. When the ball is kicked, observe its initial trajectory, but do not watch the flight of the ball. Observe players in your area of responsibility (defined by the diagrams in section 26.4) – their eyes will tell you where the ball is going. However, if the returner moves as a decoy, do not follow them - observe the area where the ball will come down.
2. [DOWN JUDGE] Stay on the line of scrimmage until the ball crosses the line, then move downfield after the players until you are approximately 15-20 yards ahead of the return. Stay wide and turn to follow the returner as they pass you.
3. [IN xx1 FORMATION (CREW OF 5/6C)] [LINE JUDGE] After the ball is kicked move downfield after the players until you are approximately 15-20 yards ahead of the return. Stay wide and turn to follow the returner as they pass you.
4. Be prepared to assist with coverage of any kick that is short, particularly to your side of the field. Mark the spot of any kick that goes out of bounds on your side however deep.
5. If the kick goes to the opposite side of the field, drift downfield observing all action, especially away from the ball. Be alert for the ball carrier returning to your side of the field and take responsibility for them if they enter your area.
6. When it appears obvious that the kicked ball will *not* land in your area:
 - (a) Maintain a position where you can cover action in front of and around the returner. If you are the nearest official *other than* the official covering the punt returner, move to where you can observe players blocking in the vicinity of any returner who is in position to catch the kick. In particular, observe those *blocked by an opponent* into interfering and therefore immune to penalty (Rule 6-4-1-d).
 - (b) If a player in your area signals for a fair catch, watch that they do not block before they touch the ball (Rule 6-5-4).
 - (c) Do not hesitate to call a foul if you clearly see one occur in the area where you are the cleanup official even though you may be a considerable distance away from the action. Communicate with your colleagues to find out their view of the action.
7. When it appears obvious that the kicked ball *will* land in your area:
 - (a) Unless you are responsible for the deepest returner, give a punch signal [Sup28] to your colleagues to indicate that you are assuming responsibility for the kick and the nearest returner.
 - (b) Move into position wide of (at least 10 yards unless they are near the sideline) and behind the returner aiming to be at a 45 degree angle to rule on the validity of the catch.
 - (c) If the kick is first muffed (but not possessed) by a member of Team B beyond the neutral zone, you may give the ball touched signal [S11] to signify that Team A is now eligible to touch it.
 - (d) Use bean bags to mark any spots of illegal touching and/or the spot where the kick ends. Only one official, the Coverer in each case, should mark each spot and give each signal. If you have more spots than bean bags, prioritise the spot most advantageous to Team B.
 - (e) If the ball becomes dead because it is caught or recovered by Team B after a fair catch signal, or caught or recovered by Team A after being touched by Team B, blow your whistle and give the timeout signal [S3]. Give the first down signal [S8] in the appropriate direction.
 - (f) If the ball is not caught and goes deeper than the returner, follow the ball and be prepared to rule on its status. Stay far enough away from it that there is no danger of it touching you.
 - (g) If the ball approaches the goal line, be *in the best position*[◊] on the goal line to rule on whether it enters the end zone. *This will normally be outside the goal line pylon (usually 2 yards or more) for your safety.*[§] Other officials will cover the players.
 - (h) If the ball does enter the end zone (untouched by Team B beyond the neutral zone) and touches the ground or is downed by Team B in the end zone, blow your whistle and signal touchback [S7], repeating the signal until you know the Referee has seen it.
 - (i) If the kick is recovered by Team A without it being touched by Team B, blow your whistle, signal timeout [S3] and give the illegal touching signal [S16] and the first down signal [S8]. Momentary touching of the ball by a player of the kicking team should not be interpreted as control of the ball.
 - (j) If the kick goes out of bounds in your area, blow your whistle and signal timeout [S3] immediately.
 - (i) If the ball touches anything (e.g. the ground or a player) in bounds and then goes out of bounds, move directly to the spot where you judge the ball crossed the sideline.

- (ii) If the ball goes out of bounds in flight, the Referee or Centre Judge *may* be able to assist by directing you to the spot. Look back to the Referee or Centre Judge to see if either can help. If either can, signal [Sup16] and respond to the instructions they give you using signals [Sup17, Sup18 & Sup19] to direct you to the crossing point. If they can't, move directly to the spot where your best judgement tells you the ball crossed the sideline.
- (iii) Hold the spot, but do not place a ball at it unless a spare is at hand.
- (k) If the ball rolls to a stop in your area, ensure no player is attempting to recover it before blowing your whistle and signalling timeout [S3].

During the punt return, respond as in the section "Returns" (above).

11.7.d – Advanced techniques

1. If Team B does not line up in a punt return formation (i.e. no deep returner), adopt your normal scrimmage down position. This is justified because if Team A does kick the ball deep, there will be no players there for you to have to cover. If the ball is kicked deep, adjust your position accordingly, but only the nearest official to the ball should need to observe it. The other officials should observe the players.
2. Be alert for cases where the kick is blocked or where there is a bad snap. This also applies if Team A switches to a run or pass formation.
 - (a) If the play turns into a run or pass, respond as you would do normally for that type of play.
 - (b) Cover the goal line and end line as appropriate (see the section in this chapter on "Goal line plays").^λ
 - (c) Be aware of the jersey numbers of the eligible receivers.
 - (d) [IN xx1 FORMATION (CREW OF 5/6C)] If the kick is blocked or the snap is loose in the backfield, hold your position on the line of scrimmage until you can read the play. If the play is to your side of the field, move into Team A's backfield to assist the Referee and to reach a place for your own safety. If the play is *to the other side or middle*² of the field, stay on the line of scrimmage at least until it becomes extremely unlikely that a kick will cross it.
 - (e) [IN 2xx FORMATION (NO C)] Assist the Referee by observing actions against the kicker, especially when the ball is on the opposite side of the field. *The Referee will have switched their responsibilities to watching the ball.*^ϕ

11.8 - Field goal & try attempts

11.8.a – Priorities

Before and during the kick, applying the same priorities as on basic scrimmage plays (above), plus:

1. [IN 2x0/2x1 FORMATION (CREW OF 4/5)] [LINE JUDGE] Ruling the success or failure of the field goal attempt. [IN 2x1 FORMATION (CREW OF 5)] You share this responsibility with the Back Judge.
 2. [DOWN JUDGE] Ruling whether the kick crossed the neutral zone, by knowing if it touches the ground, a player or official beyond the neutral zone.
 3. Observing fouls by all players generally in your area, but particularly:
 - (a) illegal block in the back and holding fouls by linemen and backs protecting the kicker and holder, especially the end and/or wing back on your side
 - (b) illegal blocks below the waist
 - (c) contacting an opponent with the crown of the helmet or targeting a defenseless opponent above the shoulders
 - (d) safety-related fouls such as face mask, tripping, chop blocks or illegal blind-side blocks
 - (e) unnecessary roughness fouls away from the ball
 - (f) late hits by any player after the ball is dead
 - (g) illegal formation
 - (h) [IN 2x0/2x1 FORMATION (CREW OF 4/5)]^ϕ [DOWN JUDGE] false start or offside by players on the Line Judge's side of the formation in addition to your own
 4. Noting the numbers of players in eligible receiver positions on your side of the formation, and observing whether anyone else is the first to touch the ball or is ineligibly downfield if the play develops into a pass play.
 5. Responding to bad snaps or blocked kicks by adopting run, pass or return priorities, as appropriate.
- If the kick is returned, applying the same priorities as on returns (above).

11.8.b – Initial positioning

[DOWN JUDGE]

1. Be in normal scrimmage down position.
2. On a try down, set the down box on the three-yard line showing down 1, and instruct the chain crew to lay the chain on the ground outside the *safety zone*[@] at around the 20-yard line, and to stand well back.

[LINE JUDGE]

3. [IN xx0 FORMATION (CREW OF 4)] Adopt the "Judge off" mechanic (211 formation). Be in position 3-5 yards behind the goal posts, in a position where you can comfortably see both goal posts without straining your neck. You have responsibility for ruling whether or not the ball passes above the crossbar and between both uprights.

4. [IN 2x1 FORMATION (CREW OF 5)] Be in position **about** one yard behind your goal post (the one nearest the press-box side of the field). You are responsible for ruling whether the ball passes inside your upright. The Back Judge has responsibility for the other upright and whether or not the ball passes above the crossbar.
5. [IN 3x1 FORMATION (CREW OF 6C)] Be in normal scrimmage down position.

11.8.c – Response to what happens (movement and signals)

1. [LINE JUDGE WHEN BEHIND GOAL POSTS]
 - (a) Observe the ball from kick to when it becomes obvious whether the attempt will be successful or not.
 - (b) If you consider the kick to be successful, communicate ("good", nod) with your colleague (if you have one) behind the posts and together come out between the uprights (approximately one yard into the end zone) giving the score signal [S5] as you come to a stop.
 - (c) If you consider the kick to have failed, give the no score signal [S10]. If the kick is wide to your side, you may also give the kick wide signal [Sup15]. Do *not* signal a touchback **unless Team B has touched the ball beyond the neutral zone.**[♠]
 - (d) Hold either signal for at least five seconds and until you know the Referee has seen it.
 - (e) [IN xx0 FORMATION (CREW OF 4)] Blow your whistle when the result of the kick is obvious. There is no need to wait until the ball touches the ground (or something else) provided it is clear what the result of the kick is/will be.
 - (f) If the kick is short or blocked and the ball is possessed by Team B, move into position to officiate the kick play as a punt **return.**[♠]
2. **[DOWN JUDGE]** and [LINE JUDGE WHEN NOT BEHIND GOAL POSTS] After the kick, jog in towards the pile of players in the middle of the field. This will force you to keep your eyes on the players and discourage you from looking to see if the kick is good or not. If trouble occurs, you will be in a better position to assist the Umpire in dealing with it.

11.8.d – Advanced techniques

1. [IN 2x1 FORMATION (CREW OF 5)] On long field goal attempts (i.e. if the ball is snapped from outside Team B's 20-yard line), it is permissible for only the Back Judge to go behind the goal posts and for the Line Judge to initially be in their normal position on the line of scrimmage. This is known as the "One Judge" mechanic. The Line Judge must clearly communicate to all other members of the crew their intention in this situation.
2. Be alert for blocked kicks and their recovery and advance. On fake kicks switch to normal run or pass coverage.
 - (a) If the play turns into a run or pass, respond as you would do normally for that type of play, bearing in mind that other officials may not respond as quickly as you. Be particularly alert to cover the goal line if necessary.
 - (b) Cover the goal line and end line as appropriate.
 - (c) [LINE JUDGE WHEN BEHIND POSTS] First, move quickly along the end line to the corner pylon to be in a position to rule on the sideline. Continue to observe the action as you do so, especially that by or against your receivers in your half of the field. Then move towards the goal line to assist with rulings there. Do *not* cut diagonally across the end zone. You have primary responsibility (with the Referee's assistance) for your sideline in the end zone.
 - (d) **Note the numbers of the (normally) two eligible receivers on your side of the offensive formation so that, if a pass develops, you can rule on ineligible touching a pass or being illegally downfield.**
 - (e) If the kick is blocked or the ball is loose in the backfield, hold your position on the line of scrimmage until you can read the play. Stay on the line of scrimmage at least until it becomes extremely unlikely that a kick will cross it. Only then should you move into Team A's backfield to assist the Referee. If the play is to your side of the field, be prepared to move for your own safety.
 - (f) **[IN 2x0/2x1 FORMATION (CREW OF 4/5)] [DOWN JUDGE] [IN 3x1 FORMATION (CREW OF 6C)] [DOWN JUDGE AND LINE JUDGE]** Assist the Referee by observing actions against the kicker and holder, **especially when the ball is on the other side of the field.** The Referee will have switched their responsibilities to watching the ball.
3. [LINE JUDGE] On a try down, instruct the alternate line-to-gain marker operator (if you have them) to lay their equipment on the ground and to stand well back.

11.9 - After each down

11.9.a – Priorities

1. Observing dead-ball action by players of both teams.
2. Encouraging the players to unpile safely, and either return the ball to an official or leave it near the dead-ball spot, as appropriate.
3. Checking whether the line to gain has been reached or is close, and signalling appropriately.
4. Checking whether any penalty flags have been thrown, and, if so:
 - (a) Giving the timeout signal [S3].

- (b) Reporting any fouls you have called to the Referee and Umpire.
 - (c) Covering penalty flags (and bean bags, if appropriate) thrown by colleagues.
 - (d) Ensuring that all penalties are enforced correctly.
 - (e) Keeping the Head Coach on your sideline informed of penalties, particularly against their team.
5. Checking for injured players or other occurrences that may delay play.
 6. [LINE JUDGE] Stopping and starting the clock when necessary.
 7. Allowing legitimate requests for timeouts. Checking that a request coming from the coaching box or team area was made by the Head Coach.
 8. Echoing all timeout signals [S3] of your colleagues.
 9. Knowing whether the play ended inbounds, and informing the Referee that the clock (if stopped) should start on the ready by giving them the clock running signal [Sup12].
 10. Assisting in relaying the dead ball or a new ball to the succeeding spot.

11.9.b – Initial positioning

1. Shortly after the end of the previous down, you should be in a position level with the succeeding spot.

11.9.c – Response to what happens (movement and signals)

1. If you are the Coverer, check whether the line to gain has been reached. [LINE JUDGE] You should normally be in a particularly good position to rule on this. If you do this consistently, the **Down Judge** will not need to turn to look at the chains to know whether the line to gain has been reached.
 - (a) If it has, give the timeout signal [S3]. After all action has ceased, signal first down [S8 or Sup35]. Hold the signal until you know the Referee is aware of it.
 - (b) If you are not sure whether the line to gain has been reached or not, signal timeout [S3] and yell "close". Encourage the Referee to come and look for themselves.
 - (c) Only place a ball on the ground at the *actual* dead-ball spot – never at a spot level with it.
 - (d) If the play ended inbounds, inform the Referee that the clock should start on the ready by giving them the clock running signal [Sup12].
2. If you are the Coverer, **give only one signal that the ball is dead**. See paragraph 6.5.14.²
3. If a penalty flag has been thrown follow the procedure in Chapter 19. **If an inadvertent whistle has been blown, follow the procedure in Section 6.15.**[§] If a team or injury timeout has been called, follow the procedure in Chapter 17. If a period has ended, follow the procedure in Chapter 20.

Moving the down box and chains:

4. [DOWN JUDGE]
 - (a) When certain that there has been no foul on the previous play (and that there is no other reason to wait), instruct the down marker to be moved to the new position, and check that the correct down number is displayed.
 - (b) When a first down is achieved, and a new line to gain is to be established, first instruct the down marker to be moved to the new position on the sideline. The chain crew should then be instructed to move quickly to their new positions.
 - (c) Anticipate any call for a measurement and be ready to bring in the chains when signalled by Referee.
5. [LINE JUDGE]
 - (a) Anticipate any call for a measurement and be ready to come in to mark the spot for the clip when signalled by the Referee.

Relaying the ball:

6. If you have the ball, but another official has the dead-ball spot and it is close to the line to gain, hand the ball to that official and allow them to spot it at the precise location (yard line *and* lateral position) where the ball became dead.
7. Unless you are the Coverer, assist in relaying a ball to the official who will place it at the succeeding spot (MOFO 6.7).
8. If a ball has been placed at the dead-ball spot in a side zone, and another ball is being relayed in to the succeeding spot, do not move the ball at the dead-ball spot until the replacement ball has been positioned at the correct location **at the inbounds spot**.⁴

Getting ready for the next down:

9. Check that there is nothing untoward going on outside your sideline or in your team area, but don't allow this duty to detract from your primary responsibilities within the field of play.
10. Verbally or visually (using signals [Sup11] or [Sup12]) inform the Referee of the correct down and clock status (if you are the Coverer), and check that the Referee indicates it correctly. Inform them immediately if an incorrect signal is given. Be aware of the new distance to the line to gain.
11. [LINE JUDGE] Remind the Referee of the clock status and, if stopped, remind them whether it should start on the snap or on the ready.
 - (a) If the clock has stopped for a foul, injury or helmet coming off and there is less than **two minutes**[®] in the half, make sure the Referee knows that there is a possible 10-second runoff.
 - (b) Be prepared for a ruling by the Referee on when the clock should start in unfair clock tactics situations.
 - (c) Start the clock when the Referee gives (or should give) the start the clock signal [S2], unless you are

sure that by rule the clock should start on the snap, or the ball is obviously not ready for play (e.g. because ball, chains, down box or officials are not in position). Do *not* echo the Referee's signal, but use the clock-on-ready signal [Sup12] if necessary to confirm that the clock has started.

- (d) If the game clock should start on the snap, start it when you see the ball legally snapped. There is no need to give a signal to confirm this.
 - (e) Your primary responsibility is to get the time accurate by rule, not to follow erroneous Referee's signals about time (**Exception:** unfair clock tactics situations), but work together to get things right (MOFO 6.12.4).[§]
12. If there are stadium game clocks, check to see that they have stopped and started correctly.
 13. If substitutions are made from your side of the field, check that Team A players fulfil the nine-yard mark requirements (Rule 7-1-3-b).
 14. Move into position for the next down. If the ball is ready for play (or will be imminently), backpedal to keep your eyes on the ball. Do not take your eyes off it for long in case the play starts while you are not looking.

11.9.d – Advanced techniques

1. The priority at the end of a play is to get into position ready for the next one. Only if a serious incident occurs (such as a foul or misconduct, an injury, or a breakage of the chain) should your routine be interrupted.
2. If Team A makes substitutions **while the snapper is at, near or moving towards** their position at the line of scrimmage:
 - (a) Any official should be prepared to step in and shut down a play that violates the substitution rule.
 - (b) Give the matching substitutes signal [Sup36] to the Referee and shout "subs on".
 - (c) Drop the signal when the Referee has taken control of the process.
3. Procedures intended to allow the defense to match up must not be used for a substitution for a last-second field goal. In that situation, Team A is making a normal and expected personnel change and Team B should be prepared to respond appropriately. In no case should an official be standing over the ball to prevent the snap as the clock runs out.[§]
4. If you want to speak to a player on the field (e.g. to warn them that they are close to fouling), it often saves time to relay the message via the Referee or Centre Judge (for a Team A player) or the Umpire or Back Judge (for a Team B player). Don't delay the game unnecessarily by entering either team's huddle, unless a timeout is still in progress. Never attempt to speak to a player during a hurry-up or no-huddle offense.
5. Maintain your concentration, and think about the next play.
6. [LINE JUDGE WHEN THERE IS AN ALTERNATE CREW]
 - (a) When the ball is declared ready for play for the next down, instruct the alternate down box operator to move their box to the new position.
 - (b) When a new line to gain is established and the chain is set, instruct the alternate line-to-gain marker operator to move it to the new position.
7. [DOWN JUDGE] Don't spend so much time interacting with the chain crew that you disregard your other duties watching players and communicating with colleagues.

12. BACK JUDGE (CREW OF 5/6C)

12.1 - Free kicks

12.1.a – Priorities

Prior to the kick:

1. Being aware of whether the Referee has instructed the crew to switch to onside-kick positions, and moving position (if appropriate) if they have.
2. Counting Team A players and signalling the count [one of Sup3, Sup4 or Sup24] to colleagues. Noting count signals from colleagues. Recounting if your count differs from that of colleagues.
3. Reminding the players to count their number if the team you are responsible for counting does not have precisely **the correct number of²** players on the field.
4. Checking readiness for play:
 - (a) Checking side areas to ensure that all non-players are out of the restricted areas, that non-participants are off the field of play, **that the safety zone is clear,[®]** and that all team personnel are within the team area.
 - (b) Ensuring that the chain crew (and the alternate down box and line-to-gain marker operators, where provided) have moved themselves and their equipment well out of the way and that the equipment has been placed on the ground outside the team areas and **outside the safety zone[®]** at the receiving team's end of the field. Checking that the ball persons are in position.
 - (c) Ensuring that all Team A players **have been within the nine-yard marks after the ready for play and prior to the kick,²** (Rule 6-1-2-c-5) and that nobody other than the kicker is more than five yards behind the ball.
 - (d) Facing the field of play to signal that you are ready. Turning away, **or obviously leaving your position,[°]** if something on your sideline becomes no longer clear or you can see that a colleague is clearly not ready. Sounding your whistle, if your area becomes dangerously unclear after the ready for play.
5. Being alert always for short kicks.

During the kick play:

6. Observing whether a free kick goes out of bounds nearest to you without being touched by the receiving team. Ruling whether a Team B player near the sideline touches the ball while out of bounds.
7. Watching players for a fair catch signal, and being prepared to rule on any interference with the opportunity to catch the kick.
8. If[×] the kick is short:
 - (a) Knowing where and by whom the ball was first touched.
 - (b) Observing illegal blocks by Team A (Rule 6-1-12).
 - (c) Marking any spot of illegal touching with a bean bag.
 - (d) Marking the dead-ball spot if you are the nearest official and there is little or no return run.
9. Giving the start the clock signal [S2] only if the ball is first legally touched in the field of play **and you are the nearest official or you have the best view of it.**
10. Observing fouls/violations by all players generally in your area, but particularly:
 - (a) illegal touching of a short kick
 - (b) infractions of your restraining line
 - (c) kicking team players (other than the kicker) more than 5 yards behind their restraining line after the ready for play
 - (d) illegal blocks in the back and holding fouls at the point of attack
 - (e) illegal blocks below the waist
 - (f) contacting an opponent with the crown of the helmet or targeting a defenseless opponent above the shoulders
 - (g) safety-related fouls such as face mask, tripping, chop blocks, illegal wedges or illegal blind-side blocks
 - (h) late hits by any player after the ball is dead
 - (i) any player of the kicking team who enters the field of play after the kick or who voluntarily goes out of bounds during the kick and returns inbounds
 - (j) **illegal forward handing or illegal forward passes**

12.1.b – Initial positioning

Normal kicks:

1. Be in position F (see 26.1) outside the press box sideline on Team A's restraining line.

Onside-kicks:

2. Remain in the normal position.

Free kicks after a penalty or safety:

- When a free kick is taken following a penalty or a safety, the same relative positions should be taken, moving up or down the field as appropriate.

12.1.c – Response to what happens (movement and signals)**Prior to the kick:**

- If anything happens that should prevent the kick taking place (e.g. a non-player enters or approaches the field of play), toot your whistle, give the timeout signal [S3] and deal with the problem.

During any kick play:

- If you see any player of the kicking team voluntarily go out of bounds during the kick, drop your bean bag or hat to mark their exit, and your flag if they return.
- If the clock should start when the ball is first legally touched in the field of play, give the start the clock signal [S2] if you are the nearest official or the one with the best view.

During a kick play that goes deep:

- After the ball is kicked, observe the players in your area of responsibility (see 26.1). After checking its initial trajectory, do not watch the flight of the ball. Move downfield along the sideline while the kick is in the air. During the return, stay ahead of the ball carrier, keeping them **boxed in**² between you and the downfield official. On a long run, be at Team A's goal line before the ball carrier. **You have shared responsibility for the goal line.**⁰ Mark the dead-ball spot if you are the nearest official when the ball carrier is tackled or is out of bounds.
- If the ball goes out of bounds in your area, go to and hold the spot, dropping your flag if appropriate.

During a kick play where the kick is short:

- Maintain a position where you can see the ball and the blocks by Team A players.
- Particularly **observe**² the blocks made by Team A players before they are eligible to touch the ball (Rule 6-1-12).
- Know where and by whom the ball was first touched. Mark any spot of illegal touching with your bean bag (Rule 6-1-3).
- If you are the nearest official when the ball becomes dead, signal timeout [S3] and mark the dead-ball spot.

12.1.d – Advanced techniques

- If an expected outside kick is instead kicked deep, move into the field of play. You and the Umpire each take responsibility for half of the middle of the field (Figure 26.1.E). Leave sideline responsibility in your area to the Line Judge.
- After the ball is dead and all action is ceased, if you are the nearest official to the previous spot make sure that any kicking tee has been removed from the field.**⁰

12.2 - Basic scrimmage plays**12.2.a – Priorities**

- Knowing the down and distance, and signalling the down to your colleagues. Noting the down signals given by colleagues. Checking that the down box displays the correct number. Not allowing play to start if there is a dispute about the down number.
- Counting Team B players and signalling the count [one of Sup3, Sup4 or Sup24] to your colleagues. Noting count signals from colleagues. Recounting if your count differs from that of colleagues.
- Identifying your key player(s) (see section 16.4). If the formation is new or unusual, verbally or visually confirming this with the other officials.
- Noting eligible receivers and those players who would normally be eligible by position but who are ineligible by number. In addition, noting players (usually tight ends) who would normally be eligible by number but who are not eligible because a player is lined up outside them on the line of scrimmage.
- Being aware of where the line to gain is in relation to the line of scrimmage so that you don't have to look at the chain to know if the dead-ball spot is close to the line to gain.
- Observing substitution infractions by both teams. For example:
 - replaced players not leaving the huddle within 3 seconds of an incoming substitute entering it
 - substitutes coming on to the field, communicating, and then leaving the field
- Alerting colleagues if Team A makes a substitution while the snapper is at, near or moving towards their position at the line of scrimmage.**[§]

12.2.b – Initial positioning

- Normally be 15-20 yards or more from the line of scrimmage, inside the hash marks.
- Be deep and clear of players, but able to see all receivers, especially your key player.
- Normally, you will be deeper than the deepest back, but be sure to keep out of their way.
- Favour the strong side of the formation, or, if it is balanced, the side of the player who is your key.

12.2.c – Response to what happens (movement and signals)

1. Always be in position to cover play from the inside looking out.
2. Be aware of a backfield player in motion at the snap. Adjust your position if necessary to ensure that you always have them in sight. They become your responsibility after the snap if they cross the neutral zone on a pass play or if they block outside the tackle on a running play.
3. If there is a pre-snap foul, maintain a position where you can see all players (especially on the fringes) who may commit a late hit.
4. Read the play to judge whether it will be a deep one that requires you to move backwards towards the goal line or end line. If the play is not a deep one, you do not need to move any deeper to cover it.

12.2.d – Advanced techniques**Reasons for varying (or not) your initial position:**

1. On "take a knee" plays, come up into a double umpire position. Tell other officials that you are doing this. Use your presence to deter unsportsmanlike acts.
2. On obvious "hail mary" plays, start deeper than normal and make sure you can get to Team B's goal line or end line before any Team A player.

Signalling the player count:

3. The latest time to make the player count signal is when the offensive team breaks its huddle (but it can and should be done earlier if possible).
4. Normally the player count signal is shared between the [Down Judge](#), Line Judge and the Back Judge.

12.3 - Running plays**12.3.a – Priorities**

1. Observing action ahead of the ball carrier.
2. Observing any fumble where you are the nearest official or have the best view, and marking the spot with a bean bag if possible.
3. Ruling whether a touchdown is scored or not on a breakaway run.
4. Observing fouls by all players generally in your area, but particularly:
 - (a) illegal block in the back and holding fouls at the point of attack, especially those made by your key player or any wide receiver, tight end, lead back or pulling lineman
 - (b) illegal block below the waist fouls by your key player and other players in your area
 - (c) contacting an opponent with the crown of the helmet or targeting a defenseless opponent above the shoulders
 - (d) safety-related fouls such as face mask, tripping, chop blocks or illegal blind-side blocks
 - (e) late hits by any player after the ball is dead
5. Getting to the goal line ahead of any ball carrier in order to be able to rule on a touchdown.

12.3.b – Response to what happens (movement and signals)

1. Move to observe actions by players behind the Umpire and ahead of the ball carrier. [Don't move deeper until you read that a long run is developing](#). Don't move forwards until you know where the ball is likely to become dead.
2. On line plunges up the middle, do not move too fast. Let the play come to you.
3. When a running play develops toward a sideline, move towards that sideline, keeping the ball carrier between you, the sideline official and the sideline. Stay ahead of the play and keep out of the way of the safeties.
4. Observe action ahead of the ball carrier and point of attack. There is no need to observe receivers ahead of the point of attack who are not blocking.
5. On long runs, try to stay ahead of the ball carrier and keep them boxed in between you and the wing official. Keep out of the players' way.
6. If you are the nearest official when the ball becomes dead, blow your whistle and move to deal with the pile. Only if the wing officials are delayed (or obviously missed a knee down or similar event) do you need to mark the dead-ball spot.
7. Be on Team B's goal line before a touchdown is scored.
8. If you are not the nearest official to the dead-ball spot, nevertheless move towards it and observe the continuing action after the ball becomes dead. On plays when the ball carrier goes near the sideline or out of bounds, cover the area around them for extra-curricular activity. If you are the second official to the area, go out of bounds after the ball carrier and watch for and prevent fouls on them (MOFO 6.8).
9. Maintain a position where you can observe player activity in fringe areas, particularly on wide-open plays.

12.3.c – Advanced techniques

1. Don't blow your whistle when the ball carrier's back is toward you or you are obscured by other players or officials² – they may have fumbled the ball without you seeing it. See leather! Be certain that the ball is dead.

2. If a pile-up of players forms, give the timeout signal [S3], converge on the pile, determine who has possession (MOFO 6.10) and encourage players to unpile safely.
3. If you're not the nearest official to the dead-ball spot, observe for late hits and other illegal acts. It is particularly your responsibility to observe action close to the wing officials as they are concentrating on the forward progress spot.
4. Because the Back Judge is not very often directly involved in running plays, it is important to maintain concentration throughout the game. You may be the only official to observe some action away from the ball or behind another official's back.

12.4 - Pass plays

12.4.a – Priorities

1. Ruling whether the pass is complete or incomplete. While primarily this will be for passes to the middle of the field, in practice you may need to rule on any pass where the receiver is facing or at right angles to you, regardless of their position. Similarly, if the receiver has their back to you, you may need to defer to another official with a better view than you.
 2. Ruling on touchdowns on passes into the end zone.
 3. Observing the initial contact by and against your key player(s).
 4. Observing fouls by all players generally in your area, but particularly:
 - (a) defensive and offensive pass interference
 - (b) defensive holding and illegal use of hands against eligible receivers
 - (c) illegal block below the waist fouls by any motion man and all players in the middle of the field
 - (d) illegal touching of a forward pass by a player who went out of bounds voluntarily (this may require consultation with a sideline colleague)
 - (e) contacting an opponent with the crown of the helmet or targeting a defenseless opponent above the shoulders
 - (f) safety-related fouls such as face mask, tripping, chop blocks or illegal blind-side blocks
 - (g) late hits by any player after the ball is dead
 5. Advising the Referee if the pass was thrown into an area not occupied by an eligible receiver.
 6. Watching for players who go out of bounds beyond the end line.
- Once the pass is complete, apply the same priorities as on a running play (above).

12.4.b – Response to what happens (movement and signals)

1. Your progression on a pass play is: (phase A) your key player; (phase B) your zone; (phase C) the destination of the pass. See also Chapter 16.
2. If you read a short pass, hold your position until the pass is caught. Then or if you read a deep pass, backpedal to keep all receivers in front of you. Don't move forwards until you know where the ball is likely to become dead. Ensure that you can see blocking and contact by and against any eligible receivers in the middle of the field. Never get beaten deep.
3. On long pass receptions, be prepared to rule on the goal line and the end line.
4. Only watch your key player during the initial action after the snap when there is a threat of illegal contact between receiver and defender. Switch to zone coverage as soon as that threat no longer exists.
5. If receivers run routes into the end zone, move into position on the end line.
6. If a potential Team A receiver voluntarily goes out of bounds in your area, drop your bean bag or hat to indicate this, and observe them to see whether they touch a forward pass while still ineligible.
7. Once you are aware that the pass has been thrown, move into position to best be able to rule on whether the pass is complete or incomplete, and whether there is interference. While the ball is in flight, watch opposing players who are contesting for the ball, not the ball itself. Be alert to both offensive and defensive pass interference.
8. If the player who attempts to catch the ball has their back to you, before making the call, look for help from any official in a better position than you.
9. If you are not the nearest official, don't just watch the receiver, but particularly watch for defenders slightly away from the ball who come in and target the receiver with the crown of their helmet or above the shoulders. This is often missed by the nearest official.
10. If the pass is a screen pass (i.e. does not cross the neutral zone), focus on the blocks in advance of the receiver, observing holding and illegal use of hands fouls in that area. §
11. If the pass is overthrown, bounces off a player or is otherwise uncatchable, continue to watch the player(s) for personal fouls (hitting a defenseless receiver). Do not ball-watch.
12. Blow your whistle if you see the ball become dead in your area.
13. If you rule that the pass is incomplete, give the incomplete pass signal [S10].
14. When contact that would have been pass interference occurs on a pass that is uncatchable, give the uncatchable pass signal [S17].
15. After an incompletion, ensure that the thrown ball is removed from the field. Repeat the incomplete pass signal [S10] to the Referee (and Umpire, if necessary) in case they did not see the original signal.
16. If there is a run after the catch, respond as you would on a running play (above).

17. On plays when the receiver goes near the sideline or out of bounds, cover the area around them for extra-curricular activity. If you are the second official to the area, go out of bounds after the ball carrier and watch for and prevent fouls on them (MOFO 6.8).
18. Maintain a position where you can see player activity in fringe areas, particularly on wide-open plays.

12.4.c – Advanced techniques

1. When an airborne player attempts to catch a pass near the sideline or end line, watch their feet first to see whether they come down in bounds. If they do, then look to their hands to see whether they have control of the ball. If you look at their hands first, you may miss the instant when their foot touches the ground (MOFO 5.4.8).
2. If the pass is incomplete in your area:
 - (a) If there is no eligible receiver in the area, move quickly towards the Referee to inform them of this. If the ball crossed the neutral zone, give signal [Sup42] by pointing to the ground beyond the neutral zone. If the ball did not cross the neutral zone, move towards the Referee while pointing to the ground behind the neutral zone.
 - (b) If there *is* a receiver in the area, and you believe the Referee may not be aware of that fact, move towards the Referee while pointing towards the eligible receiver. Calling out "Number 34 was in the area of the pass" (for example) is also permissible.
 - (c) [USING O2O/CREW RADIO] Transmitting this information is also an option.

12.5 - Goal line plays

12.5.a – Priorities

Same priorities as on other scrimmage plays, plus:

1. Ruling whether a touchdown is scored or not. This includes all passes into the end zone, and running plays if the ball is snapped outside Team B's 7-yard line.
2. Observing players' celebrations after a score.

12.5.b – Initial positioning

1. [SNAP FROM BETWEEN TEAM B'S 15 AND 7-YARD LINES] Start in the end zone and move to cover the goal line, unless a pass into the end zone is likely in which case move to cover the end of the pass or whichever line (goal line or end line) it is near.
2. [SNAP FROM ON OR INSIDE TEAM B'S 7-YARD LINE] Start on the end line.

12.5.c – Response to what happens (movement and signals)

1. Move to observe all players in your area of responsibility. If a pass is thrown into the end zone, move to the best position to rule on the end of the pass. If the pass is thrown into a deep corner of the end zone, this will normally be somewhere on the end line between the hash marks and the nine-yard marks.
2. Indicate a score by blowing your whistle and giving the touchdown signal [S5] only when you clearly see the ball break the plane of the goal line in player possession or if you see a pass completed in the end zone.
3. If a pile-up forms at the goal line, come into the field of play until you can see the ball. If you are the nearest official, you may need to dig for it. Check with other officials that they did not see the ball carrier down (or fumble the ball) before [the ball²](#) reached the goal line.
4. Do not give a score signal if you have thrown a penalty flag for a foul by the scoring team. Do not blow your whistle or give any signal if you are not sure about the outcome of the play.
5. If you have goal line responsibility, straddle the goal line – don't run after the player into the end zone unless there is a threat of trouble by or against them, but do turn to keep your eyes on them to observe late hits or unsportsmanlike conduct.
6. If another official has sideline responsibility, do not signal touchdown until you have confirmed with them that the ball carrier was not out of bounds.
7. Maintain the touchdown signal until you know the Referee has seen it, but keep your eyes on the players – don't look to the Referee until all action has ceased. Don't run and signal at the same time. You should not echo the signals of other officials unless the Referee cannot see their signal.
8. It is especially important on goal line plays that all covering officials indicate the same point of forward progress. Communicate if in doubt. Signal only if sure.
9. If the end of the play is not in your area of responsibility, move into position to assist in the clean-up of continuing action around or away from the ball.

12.6 - Returns

12.6.a – Priorities

1. Observing the ball carrier and action around them while you are the nearest official.
2. Observing any fumble where you are the nearest official or have the best view, and marking the spot with a bean bag.

3. Observing blocks by players in your area of responsibility ahead of and around the ball carrier, particularly:
 - (a) illegal block in the back and holding fouls at the point of attack
 - (b) illegal block below the waist fouls anywhere
 - (c) safety-related fouls such as face mask, tripping, chop blocks or illegal blind-side blocks
 - (d) assisting the runner
 - (e) contacting an opponent with the crown of the helmet or targeting a defenseless opponent above the shoulders
 - (f) late hits by any player after the ball is dead
4. Observing any *legal*^o hand-off or pass where you are the nearest official or have the best view, and marking the spot with a bean bag.
5. Observing any *illegal* forward pass or forward handing, especially if you have a view that is level or nearly level with the ball carrier.

12.6.b – Response to what happens (movement and signals)

1. Keep out of the players' way.
2. Move towards Team A's goal line following the play.
3. Observe the ball carrier while they remain in the middle of the field or until they pass the nearest wing official.
4. If you are watching a block develop, stay with it before switching to the ball carrier or another block. Even if you expect another official to take responsibility for it, stay with the block until you are confident it is legal.
5. If the ball becomes dead in your area of responsibility, blow your whistle, give the timeout signal [S3], and then signal first down [S8] to show which team is in possession. Hold the signal until you know the Referee has seen it.
6. If you are not the nearest official to the dead-ball spot, nevertheless move towards it and observe the continuing action after the ball becomes dead. On plays when the ball carrier goes near the sideline or out of bounds, move laterally to cover the area around them for extra-curricular activity. If you are the second official to the area, go out of bounds after the ball carrier and watch for and prevent fouls on them (MOFO 6.8).

12.7 - Punts

12.7.a – Priorities

Before and during the kick, applying the same priorities as on basic scrimmage plays (above), plus:

1. Marking the end of the kick (if inbounds) with a bean bag.
2. Ruling whether players touched the ball or not.
3. Observing any fair catch signals by players in your area.
4. Observing kick-catch interference against a player in position to catch the kick, if the kick comes down in your area.
5. If the kick does not come down in your area, observing players who have *not* committed kick-catch interference because they were blocked by an opponent into the returner.
6. Marking all spots of illegal touching with a bean bag.
7. Ruling whether a momentum exception applies or not near the goal line.
8. Observing fouls by all players generally in your area, but particularly:
 - (a) illegal blocks below the waist, especially by players in the middle of the field
 - (b) during the kick, illegal block in the back and holding fouls against Team A players trying to get down the field
 - (c) a Team A player returning inbounds after voluntarily going out of bounds during the down (*dropping*² your bean bag or hat to mark their exit, and your flag if they return)
 - (d) kick catch interference when the kicked ball will land in your area
 - (e) illegal blocks made by players who have signalled for a fair catch
 - (f) contacting an opponent with the crown of the helmet or targeting a defenseless opponent above the shoulders
 - (g) safety-related fouls such as face mask, tripping, chop blocks or illegal blind-side blocks
 - (h) unnecessary roughness fouls away from the ball
 - (i) late hits by any player after the ball is dead
9. Responding to bad snaps or blocked kicks by adopting run, pass or return priorities, as appropriate.

During *the* punt return, applying the same priorities as on returns (above).

12.7.b – Initial positioning

1. Be behind and to the side of the deepest returner. Behind so that you can look through them and see the ball kicked. To the side so that you are out of their way, but still close enough to observe whether they touch the ball or not, or whether any opponent interferes with their opportunity to catch the kick. About 5-8 yards behind and 5-8 yards to the side is an appropriate distance, allowing for the speed of the returner and weather conditions. If there is more than one returner deep, take position where you can see all of them.

2. [SNAP FROM INSIDE TEAM B'S 40-YARD LINE OR THE PUNT RETURNER IS INSIDE TEAM B'S 10-YARD LINE] Be in an initial position on the goal line in the middle of the field.
3. Be prepared to adjust your position according to the strength and direction of the wind, and the ability of the kicker. Move closer to the sideline where the wind is likely to carry the kicked ball.
4. Have a bean bag readily available and a second one to hand.
5. You will have responsibility for the end of the kick, unless it ends very close to a sideline [or you are well out of position](#),[§] in which case it is the responsibility of the nearest sideline official.

12.7.c – Response to what happens (movement and signals)

1. When the ball is kicked, observe its initial trajectory, but do not watch the flight of the ball. Observe players in your area of responsibility (defined by the diagrams in section 26.4) – their eyes will tell you where the ball is going. However, if the returner moves as a decoy, do not follow them - observe the area where the ball will come down.
2. When it appears obvious that the kicked ball will *not* land in your area:
 - (a) If the kick is short and to either sideline, the sideline official will assume responsibility for the ball. They will give the punch signal [Sup28] to indicate this.
 - (b) Maintain a position where you can cover action in front of and around the returner. If you are the nearest official *other than* the official covering the punt returner, move to where you can observe players blocking in the vicinity of any returner who is in position to catch the kick. In particular, observe those *blocked by an opponent* into interfering and therefore immune to penalty (Rule 6-4-1-d).
 - (c) If a player in your area signals for a fair catch, watch that they do not block before they touch the ball (Rule 6-5-4).
 - (d) Do not hesitate to call a foul if you clearly see one occur in the area where you are the cleanup official even though you may be a considerable distance away from the action. Communicate with your colleagues to find out their view of the action.
3. When it appears obvious that the kicked ball *will* land in your area:
 - (a) Move into position wide of (at least 10 yards unless they are near the sideline) and behind the returner aiming to be at a 45 degree angle to rule on the validity of the catch.
 - (b) If the kick is first muffed (but not possessed) by a member of Team B beyond the neutral zone, you may give the ball touched signal [S11] to signify that Team A is now eligible to touch it.
 - (c) Use bean bags to mark any spots of illegal touching and/or the spot where the kick ends. Only one official, the Coverer in each case, should mark each spot and give each signal. If you have more spots than bean bags, prioritise the spot most advantageous to Team B.
 - (d) If the ball becomes dead because it is caught or recovered by Team B after a fair catch signal, or caught or recovered by Team A after being touched by Team B, blow your whistle and give the timeout signal [S3]. Give the first down signal [S8] in the appropriate direction.
 - (e) If the ball is not caught and goes deeper than the returner, follow the ball and be prepared to rule on its status. Stay far enough away from it that there is no danger of it touching you.
 - (f) If the ball approaches the goal line, be [in the best position](#)[°] on the goal line to rule on whether it enters the end zone. Other officials will cover the players.
 - (g) If the ball does enter the end zone (untouched by Team B beyond the neutral zone) and touches the ground or is downed by Team B in the end zone, blow your whistle and signal touchback [S7], repeating the signal until you know the Referee has seen it.
 - (h) If the kick is recovered by Team A without it being touched by Team B, blow your whistle, signal timeout [S3] and give the illegal touching signal [S16] and the first down signal [S8]. Momentary touching of the ball by a player of the kicking team should not be interpreted as control of the ball.
 - (i) If the ball rolls to a stop in your area, ensure no player is attempting to recover it before blowing your whistle and signalling timeout [S3].

During the punt return, respond as in the section "Returns" (above).

12.7.d – Advanced techniques

1. If Team B does not line up in a punt return formation (i.e. no deep returner), adopt your normal scrimmage down position. This is justified because if Team A does kick the ball deep, there will be no players there for you to have to cover. If the ball is kicked deep, adjust your position accordingly, but only the nearest official to the ball should need to observe it. The other officials should observe the players.
2. Be alert for cases where the kick is blocked or where there is a bad snap. This also applies if Team A switches to a run or pass formation.
 - (a) If the play turns into a run or pass, respond as you would do normally for that type of play.
 - (b) Cover the goal line and end line as appropriate ([see the section in this chapter on "Goal line plays"](#)).^λ
 - (c) Be aware of the jersey numbers of the eligible receivers.

12.8 - Field goal & try attempts

12.8.a – Priorities

Before and during the kick, applying the same priorities as on basic scrimmage plays (above), plus:

1. Ruling the success or failure of the field goal attempt. You share this responsibility with [IN 3x1 FORMATION (CREW OF 6C)] the Centre Judge [IN 2x1 FORMATION (CREW OF 5)] the Line Judge (unless they remain in the offensive backfield or on the line of scrimmage, in which case you have sole responsibility).
2. Observing illegal touching or batting of the ball.
3. Observing players' celebrations after a score.
4. Noting the numbers of players in eligible receiver positions and observing whether anyone else is the first to touch the ball or is ineligibly downfield if the play develops into a pass play.
5. Responding to bad snaps or blocked kicks by adopting run, pass or return priorities, as appropriate.

During a field goal return, applying the same priorities as on returns (above).

12.8.b – Initial positioning

1. Take position about one yard behind the goal post furthest from the press box. You are responsible for ruling whether the ball passes inside your upright **and above the crossbar**.^λ [IN 3x1 FORMATION (CREW OF 6C)] The Centre Judge has responsibility for the other upright. [IN 2x1 FORMATION (CREW OF 5)] The Line Judge has responsibility for the other upright.

12.8.c – Response to what happens (movement and signals)

1. Observe the ball from kick to when it becomes obvious whether the attempt will be successful or not.
2. If you consider the kick to be successful, communicate ("good", nod) with your colleague (if you have one) behind the posts and together come out between the uprights (approximately one yard into the end zone) giving the score signal [S5] as you come to a stop.
3. If you consider the kick to have failed, give the no score signal [S10]. If the kick is wide to your side, you may also give the kick wide signal [Sup15]. Do *not* signal a touchback **unless Team B has touched the ball beyond the neutral zone**.^ϕ
4. Hold either signal for at least five seconds and until you know the Referee has seen it.
5. Blow your whistle when the result of the kick is obvious. There is no need to wait until the ball touches the ground (or something else) provided it is clear what the result of the kick is/will be.
6. If the kick is short or blocked and the ball is possessed by Team B, move into position to officiate the kick play as a punt **return**.^λ

12.8.d – Advanced techniques

1. On long field goal attempts (i.e. if the ball is snapped from outside Team B's 20-yard line), it is permissible for only the Back Judge to go behind the goal posts and for the Line Judge (and Centre Judge) to initially be in their normal position. This is known as the "One Judge" mechanic. If so, be 3-5 yards behind the goal posts, in a position where you can comfortably see both goal posts without straining your neck.
2. **Note the numbers of the (normally) two eligible receivers on your side of the offensive formation so that, if a pass develops, you can rule on ineligibles touching a pass or being illegally downfield.**[§]
3. Be alert for cases where the kick is blocked or where there is a bad snap. This also applies if Team A switches to a run or pass formation.
 - (a) Stay in position as long as there is the possibility of a drop kick attempt.
 - (b)^λ If a run or pass develops, read the play and respond as appropriate.
 - (i) On an obvious running play or pass play short of the goal line, you may need to come infield and cover the goal line. **This is normally the official behind the post furthest from the play, in order to help box in the goal line with any trailing wing official.**[§]
 - (ii) Stay on the end line if a pass into the end zone is possible.
 - (c) If the ball is recovered and advanced by Team B, follow the return up the field.

12.9 - After each down

12.9.a – Priorities

1. Observing dead-ball action by players of both teams.
2. Encouraging the players to unpile safely, and either return the ball to an official or leave it near the dead-ball spot, as appropriate.
3. Checking whether the line to gain has been reached or is close, and signalling appropriately.
4. Checking whether any penalty flags have been thrown, and, if so:
 - (a) Giving the timeout signal [S3].
 - (b) Reporting any fouls you have called to the Referee and Umpire.
 - (c) Covering penalty flags (and bean bags, if appropriate) thrown by colleagues.
 - (d) Ensuring that all penalties are enforced correctly.
5. Checking for injured players or other occurrences that may delay play.

6. [ON-FIELD PLAY CLOCK OPERATOR] Starting the play clock when necessary, giving a 10-second warning, and throwing a delay of game flag if the clock reaches 0 before the ball is put in play.
7. Allowing legitimate requests for timeouts. Checking that a request coming from the coaching box or team area was made by the Head Coach.
8. Echoing all timeout signals [S3] of your colleagues.
9. Assisting in relaying the dead ball or a new ball to the succeeding spot.
10. If you are not covering the play, assisting in maintaining order on the field by moving towards where the play ended.

12.9.b – Response to what happens (movement and signals)

1. If you are the Coverer, check whether the line to gain has been reached.
 - (a) If it has, give the timeout signal [S3]. After all action has ceased, signal first down [S8 or Sup35]. Hold the signal until you know the Referee is aware of it.
 - (b) If you are not sure whether the line to gain has been reached or not, signal timeout [S3] and yell "close". Encourage the Referee to come and look for themselves.
 - (c) Only place a ball on the ground at the *actual* dead-ball spot – never at a spot level with it.
 - (d) If the play ended inbounds, inform the Referee that the clock should start on the ready by giving them the clock running signal [Sup12].
2. If you are the Coverer, **give only one signal that the ball is dead**. See paragraph 6.5.14.⁴
3. If a penalty flag has been thrown follow the procedure in Chapter 19. **If an inadvertent whistle has been blown, follow the procedure in Section 6.15.**[§] If a team or injury timeout has been called, follow the procedure in Chapter 17. If a period has ended, follow the procedure in Chapter 20.
4. [ON-FIELD PLAY CLOCK OPERATOR] If a 40-second clock should start by rule:
 - (a) If there is a stadium play clock, check that it started shortly after the end of the play.
 - (b) If there is no stadium play clock, start a 40-second count shortly after the end of the play.

Relaying the ball:

5. If you have the ball, but another official has the dead-ball spot and it is close to the line to gain, hand the ball to that official and allow them to spot it at the precise location (yard line *and* lateral position) where the ball became dead.
6. Unless you are the Coverer, assist in relaying a ball to the official who will place it at the succeeding spot (MOFO 6.7).
7. If a ball has been placed at the dead-ball spot in a side zone, and another ball is being relayed in to the succeeding spot, do not move the ball at the dead-ball spot until the replacement ball has been positioned at the correct location **at the inbounds spot**.⁴

Getting ready for the next down:

8. Move into position for the next down. If the ball is ready for play (or will be imminently), backpedal to keep your eyes on the ball. Do not take your eyes off it for long in case the play starts while you are not looking.
9. If the ball is not ready for play 20 seconds into the play count (Rule 3-2-4-b-3), signal to the Referee [Sup29] that the play clock should be reset to 25 seconds.
10. If there is no visible play clock:[@]
 - (a) **[USING O2O/CREW RADIO] when approximately 12 seconds remain on the play clock, alert colleagues with "10 seconds";**
 - (b) when approximately 10 seconds remain on the play clock, raise a hand high in the air [signal S7] until either the ball is snapped or a delay of game flag is thrown. Do not give any additional signal (e.g. a countdown).
11. When the play clock reaches 0, look at the snapper. If the ball is already moving, there is no foul. Otherwise, blow your whistle and throw your flag for delay of game.

12.9.c – Advanced techniques

1. The priority at the end of a play is to get into position ready for the next one. Only if a serious incident occurs (such as a foul or misconduct, an injury, or a breakage of the chain) should your routine be interrupted.
2. **Double check that the Spotter has put the ball at the correct lateral position.**[§]
3. If Team A makes substitutions **while the snapper is at, near or moving towards** their position at the line of scrimmage:
 - (a) Any official should be prepared to step in and shut down a play that violates the substitution rule.
 - (b) Give the matching substitutes signal [Sup36] to the Referee and shout "subs on".
 - (c) **Drop the signal when** the Referee has taken control of the process.
4. **Procedures intended to allow the defense to match up must not be used for a substitution for a last-second field goal. In that situation, Team A is making a normal and expected personnel change and Team B should be prepared to respond appropriately. In no case should an official be standing over the ball to prevent the snap as the clock runs out.**[§]
5. If you want to speak to a player on the field (e.g. to warn them that they are close to fouling), it often saves time to relay the message via the Referee or Centre Judge (for a Team A player). Don't delay the game unnecessarily by entering either team's huddle, unless a timeout is still in progress. Never attempt to speak to a player during a hurry-up or no-huddle offense.
6. Maintain your concentration, and think about the next play.

13. DOWN JUDGE AND LINE JUDGE (CREW OF 6D/7/8)

13.1 - Free kicks

13.1.a – Priorities

Prior to the kick:

1. Being aware of whether the Referee has instructed the crew to switch to onside-kick positions, and moving position (if appropriate) if they have.
2. Counting Team B players and signalling the count [one of Sup3, Sup4 or Sup24] to colleagues. Noting count signals from colleagues. Recounting if your count differs from that of colleagues.
3. Reminding the players to count their number if the team you are responsible for counting does not have precisely **the correct number of[‡]** players on the field.
4. Checking readiness for play:
 - (a) Checking side and end zone areas to ensure that all non-players are out of the restricted areas, that non-participants are off the field of play, **that the safety zone is clear,[®]** and that all team personnel are within the team area.
 - (b) Ensuring that the chain crew (and the alternate down box and line-to-gain marker operators, where provided) have moved themselves and their equipment well out of the way and that the equipment has been placed on the ground outside the team areas and **outside the safety zone[®]** at the receiving team's end of the field. Checking that the ball persons are in position.
 - (c) Facing the field of play to signal that you are ready. Turning away, **or obviously leaving your position,[◊]** if something on your sideline becomes no longer clear or you can see that a colleague is clearly not ready. Sounding your whistle, if your area becomes dangerously unclear after the ready for play.
5. Being alert always for short kicks.

During the kick play:

6. Observing whether a free kick goes out of bounds nearest to you without being touched by the receiving team. Ruling whether a Team B player near the sideline touches the ball while out of bounds.
7. Watching players for a fair catch signal, and being prepared to rule on any interference with the opportunity to catch the kick.
8. If[×] the kick is short:
 - (a) Knowing where and by whom the ball was first touched.
 - (b) Observing illegal blocks by Team A (Rule 6-1-12).
 - (c) Marking any spot of illegal touching with a bean bag.
 - (d) Marking the dead-ball spot if you are the nearest official and there is little or no return run.
9. Giving the start the clock signal [S2] only if the ball is first legally touched in the field of play **and you are the nearest official or you have the best view of it.**
10. Ruling whether the ball becomes dead in the end zone or not.
11. Marking the forward progress or out of bounds spot if the ball becomes dead on your side of the field. This responsibility extends up to Team A's 2-yard line.
12. Marking the spot with a bean bag of any backward pass, handing or fumble in your area.
13. Observing fouls/violations by all players generally in your area, but particularly:
 - (a) illegal touching of a short kick
 - (b) illegal blocks in the back and holding fouls at the point of attack
 - (c) illegal blocks below the waist
 - (d) contacting an opponent with the crown of the helmet or targeting a defenseless opponent above the shoulders
 - (e) safety-related fouls such as face mask, tripping, chop blocks, illegal wedges or illegal blind-side blocks
 - (f) late hits by any player after the ball is dead
 - (g) any player of the kicking team who enters the field of play after the kick or who voluntarily goes out of bounds during the kick and returns inbounds
 - (h) **illegal forward handing or illegal forward passes**

13.1.b – Initial positioning

Normal kicks:

1. **[DOWN JUDGE]** Be in position C (see 26.1) **slightly behind[◊]** Team B's goal line outside the sideline opposite the press box side of the field.
2. **[LINE JUDGE]** Be in position B (see 26.1) **slightly behind[◊]** Team B's goal line outside the sideline on the press box side of the field.
3. Stand where you can see in a straight line over the pylon towards where the kick will come from.

Onside-kicks:

4. [LINE JUDGE]
 - (a) [IN F6 FORMATION (CREW OF 6)] Move to position D (see 26.1) outside the press box sideline on Team B's restraining line.
 - (b) [IN F7-8 FORMATION (CREW OF 7/8)] Remain in the normal position.
5. [DOWN JUDGE]
 - (a) [IN F6-7 FORMATION (CREW OF 6/7)] Move to position E (see 26.1) outside the sideline opposite the press box on Team B's restraining line.
 - (b) [IN F8 FORMATION (CREW OF 8)] Remain in the normal position.

Free kicks after a penalty or safety:

6. When a free kick is taken following a penalty or a safety, the same relative positions should be taken, moving up or down the field as appropriate.

13.1.c – Response to what happens (movement and signals)**Prior to the kick:**

1. If anything happens that should prevent the kick taking place (e.g. a non-player enters or approaches the field of play), toot your whistle, give the timeout signal [S3] and deal with the problem.

During any kick play:

2. If you see any player of the kicking team voluntarily go out of bounds during the kick, drop your bean bag or hat to mark their exit, and your flag if they return.
3. If the clock should start when the ball is first legally touched in the field of play, give the start the clock signal [S2] if you are the nearest official or the one with the best view.

During a kick play that goes deep:

4. After the ball is kicked, observe the players in your area of responsibility (see 26.1). After checking its initial trajectory, do not watch the flight of the ball.
5. If the kick threatens to go into the end zone, [step up to the goal line extended](#)[◊] (out of the way of all players) to rule on a touchback. If the ball threatens the pylon, be there to be able to rule on whether the ball goes out of bounds in the field of play or the end zone.
6. If the live ball and at least one player go deep into the end zone, move to cover the end line.
7. If the kick clearly goes to the opposite side of the field to you, move upfield about 10 yards to get a better/different angle on lead blocks and any illegal wedges.
8. If a touchback occurs:
 - (a) Sound your whistle loudly to prevent further action.
 - (b) Move infield ahead of any receiver who has the ball. Until you get in front of them, continue to watch them in case they are fouled.
 - (c) Give the touchback signal [S7].
9. On a deep kickoff, follow the ball carrier and keep them [boxed in](#)² between you and the upfield officials.
10. If the ball goes out of bounds in your area, go to and hold the spot, dropping your flag if appropriate.

During a kick play where the kick is short:

11. Maintain a position where you can see the ball and the blocks by Team A players.
12. Know where and by whom the ball was first touched. Mark any spot of illegal touching with your bean bag (Rule 6-1-3).
13. If you are the nearest official when the ball becomes dead, signal timeout [S3] and mark the dead-ball spot.

13.1.d – Advanced techniques

1. You may adjust your position according to such factors as the free kick spot, the wind and the known strength of the kicker's foot. However, it is important to be on the goal line (and particularly, at the pylon) before the ball gets there in crucial situations. [If the ball threatens the pylon, be in line with the kick so that you can rule whether the ball crosses the goal line or the sideline first.](#)[§]
2. [After the ball is dead and all action is ceased, if you are the nearest official to the previous spot make sure that any kicking tee has been removed from the field.](#)[◊]

13.2 - Basic scrimmage plays**13.2.a – Priorities**

1. Knowing the down and distance, and signalling the down to your colleagues. Noting the down signals given by colleagues. Checking that the down box displays the correct number. Not allowing play to start if there is a dispute about the down number.
2. Observing false starts in general and, in particular, by linemen and backs on your side of the formation. [This includes when Team A never sets.](#)
3. [Observing other illegal shifts \(no 1-second pause after simultaneous movement by Team A players\).](#)[◊]
4. Observing offside (and other line of scrimmage infractions) by Team B players (especially those between you and the ball).
5. Observing illegal motion by Team A players on your side of the formation.

6. Observing the legality of the snap.
7. If there is a pre-snap foul, stopping all action by tooting on your whistle and giving the timeout signal [S3].
8. Anticipating whether the play is a run or a pass by reading the initial action of the interior linemen. If they move backwards it is likely that a pass play will develop. If they charge forwards or pull, it is likely that a running play will develop.
9. Identifying your key player(s) (see sections 16.5 and 16.6). If the formation is new or unusual, verbally or visually confirming this with the other officials.
10. Noting eligible receivers and those players who would normally be eligible by position but who are ineligible by number. In addition, noting players (usually tight ends) who would normally be eligible by number but who are not eligible because a player is lined up outside them on the line of scrimmage.
11. Watching the tackle on your side of the formation if there is no tight end on your side.
12. Being aware of where the line to gain is in relation to the line of scrimmage so that you don't have to look at the chain to know if the dead-ball spot is close to the line to gain.
13. Observing substitution infractions by both teams (especially the team on your side of the field). For example:
 - (a) replaced players not leaving the huddle within 3 seconds of an incoming substitute entering it
 - (b) replaced players not being off the field before the snap
 - (c) substitutes coming on to the field, communicating, and then leaving the field
14. Ensuring that coaches and substitutes are behind the coaching box line and that your sideline is clear of any obstructions.
15. [DOWN JUDGE] Noting whether the chains and down box are in their proper position, but only preventing play if there is a serious problem.
16. Observing the legality of the formation, in particular that there are no more than 4 players in the backfield.
17. Alerting colleagues if Team A makes a substitution while the snapper is at, near or moving towards their position at the line of scrimmage. §
18. Indicating Team A's scrimmage line (the tail of the ball) using your foot that is nearest their goal line.
19. Until the ball is snapped, § indicating, using the off-the-line signal [Sup1], when the Team A player closest to you is off the line of scrimmage.
20. Observing whether all Team A players have met the requirement for being within the nine-yard marks.
21. [DOWN JUDGE] If the distance to the line to gain is approximately 5 yards, know whether a 5-yard penalty would give a first down or not.

13.2.b – Initial positioning

1. Be where you can see the entire neutral zone, and the ball at the snap.
2. Normal scrimmage down position is in the neutral zone, at least one yard outside the sideline. †
3. [DOWN JUDGE] Be on the side of the field opposite the press box.
4. [LINE JUDGE] Be on the press box side of the field.
5. Never adopt a position that restricts the positioning or movement of players.
6. Never speak to players or coaches when the snap is imminent.

13.2.c – Response to what happens (movement and signals)

1. In the event of sudden movement by Team A players, come in quickly and confer with the Umpire to determine which team was responsible.
2. If one or more Team B players enter the neutral zone, watch the reaction by Team A players who may be threatened. Watch for when the Team B players get back to their own side of the neutral zone.
3. If there is a foul before the snap, blow your whistle, throw your flag and signal timeout [S3]. Come in quickly to the succeeding spot to prevent any play and to confer with the Umpire and the other wing official about the call. However, if there is no possibility of doubt about what the foul is, you may give a miniature penalty signal [e.g. S18 or S19] to the Referee without coming in all the way or [USING O2O/CREW RADIO] transmit the foul to all colleagues. @

13.2.d – Advanced techniques

Reasons for varying (or not) your initial position:

1. You get a much better view of everything from a wide position. It also prevents you being caught inside on a sweep play or out-pattern pass. ×
2. If a Team A player asks you whether they are on or off the line of scrimmage, inform them how they can use your signals to tell for themselves. Do not say anything to the player that might cause them to move immediately prior to the snap. Do not answer questions like "Am I on/off the line?" with a yes/no response, since you may have misheard the question. The fact that you are indicating the line with your foot and not using the off-the-line signal [Sup1] is sufficient to indicate to all concerned that the player nearest you is *on* the line. No separate signal is necessary or desirable.
3. If there is more than one receiver close to you off the line, you may optionally show the number by outstretching fingers at the end of your off-the-line signal [Sup1].
4. Do not attempt to give the off-the-line signal [Sup1] and a Team B player count signal [either Sup3 or Sup24] at the same time. Two outstretched arms may be misinterpreted as the matching substitutes signal [Sup36]. @

13.3 - Running plays

13.3.a – Priorities

1. Observing the ball carrier and action around them.
2. Blowing your whistle and marking the forward progress or out of bounds spot if the ball becomes dead in the middle or on your side of the field. This responsibility extends up to Team B's 2-yard line. If the ball goes to the other side of the field, backing up your colleague on the other side of the field by either estimating the dead-ball spot or mirroring their spot.
3. Observing any fumble where you are the nearest official or have the best view, and marking the spot with a bean bag.
4. Observing fouls by all players generally in your area, but particularly:
 - (a) illegal block in the back and holding fouls at the point of attack, especially those made by a wide receiver, tight end, lead back or pulling lineman
 - (b) illegal block below the waist fouls by players on your side of the formation
 - (c) safety-related fouls such as face mask, tripping, chop blocks or illegal blind-side blocks
 - (d) late hits by any player after the ball is dead
 - (e) unnecessary roughness against the quarterback after they have handed off or pitched the ball on a play away from you
5. Ruling (with help from the Referee or Centre Judge on passes from deep in the backfield) whether a pass is backward or forward, and signalling a backward pass [Sup5] immediately if the pass is clearly backward. Noting any backward pass signal from the Referee or Centre Judge. **Not attempting²** to make a pass/fumble ruling if the passer is contacted — leave that to the Referee or Centre Judge. [§]

13.3.b – Response to what happens (movement and signals)

1. If the run comes to your side of the field:
 - (a) Retreat at an angle out of bounds and towards Team A's end line if necessary.
 - (b) Pick up coverage of the ball carrier as they approach the neutral zone in your area.
 - (c) Let the ball carrier get ahead of you, then follow them downfield until the ball becomes dead, keeping out of the way of all players.
 - (d) Once the ball becomes dead, blow your whistle and move to a point level with the forward progress spot.
 - (e) If the ball becomes dead inbounds and near the sideline, be prepared to take forward progress from your wing colleague using cross-field mechanics if the ball carrier is driven back towards you.
2. If the run goes up the middle:
 - (a) Stay wide but approximately level with the ball carrier's progress.
 - (b) Come in when the play is dead to rule on forward progress. Come in until you meet resistance (do not leap over players). **Exception:** Don't come in if Team A is in a hurry-up offense (or should be) and the clock is still running.
 - (c) Only blow the whistle if you can clearly see the ball and the player in possession.
3. If the run goes to the opposite side of the field:
 - (a) Stay wide but approximately level with the ball carrier's progress.
 - (b) Keep your eyes open for cheap shots behind the play.
 - (c) Stay focused – be alert for reverses.
 - (d) When the ball becomes dead, move level with the dead-ball spot. Do not blow your whistle.
 - (e) If your colleague on the opposite side of the field is unable to get to the dead-ball spot quickly (e.g. because the ball becomes dead close to the sideline or the ball carrier is driven back):
 - (i) Assist them by staying in position level with your best judgement of the forward progress spot (cross-field mechanics), but do not be obtrusive about this.
 - (ii) Hold this position long enough to allow them an opportunity to mirror your spot if they are unable to judge it themselves, but give it up when the Coverer obviously indicates a forward progress spot of their own.
 - (iii) If the Coverer marks a very inaccurate spot, unobtrusively attract their attention to your spot. **[USING O2O/CREW RADIO] is one way of doing this, particularly if they are looking away from you (MOFO 25.5.1).** [§]
4. On a long run:
 - (a) Follow the play, maintaining as good a view as possible of the ball carrier and the players near them. Be prepared to close in when the ball becomes dead and mark the forward progress spot.
 - (b) Occasionally, the deep wing official may be in a better position than you to cover the ball carrier, in which case they may be the one to declare the ball dead and mark the forward progress. However, this should not be normal practice **unless the play ends inside Team B's 2-yard line[§]** — keep up with the play!
5. If the run ends behind the line of scrimmage:
 - (a) Assist the Referee (or Centre Judge) in determining forward progress.
6. Remain out of bounds until you are certain the ball is becoming dead. Never turn your back on the ball.

Covering the dead-ball spot:

7. When marking forward progress, converge to the dead-ball spot when play in your area permits. Square off, i.e. move parallel to the sideline then in, rather than diagonally. This is particularly important on pivotal plays that end around the line to gain or goal line, where *selling* the spot may be crucial (MOFO 5.7).
8. Be alert to cover the forward progress spot when the ball carrier has been driven back, but watch the ball carrier (and action against them), not the spot. Do not leap over or pass players to reach the forward progress spot: keep them in front of you. Drop your bean bag *only* if you are forced to leave your spot.
9. If the ball goes out of bounds on your side of the field, signal timeout [S3]. Normally, you have forward progress all the way up to Team B's 2-yard line. Unless the deep wing official is much closer than you, move to the dead-ball spot once players have cleared the immediate area. Stop on the sideline and watch any continuing action in the out-of-bounds area.
10. If absolutely necessary, mark the dead-ball spot with your bean bag and go out-of-bounds to prevent/stop continuing action.
11. Once all action has ceased, help (if needed) to retrieve/relay another ball to the Spotter (MOFO 6.7).
12. If the ball becomes dead within approximately 10 feet of the sideline and the clock should not stop for any other reason, give the wind the clock signal [S2].
13. If the ball carrier goes out of bounds in the deep wing official's area, go into the team area as far as the ball carrier and observe any actions against them.

13.3.c – Advanced techniques

1. Don't blow your whistle when the ball carrier's back is toward you or you are obscured by other players or officials² – they may have fumbled the ball without you seeing it. See leather! Be certain that the ball is dead.
2. If a pile-up of players forms, give the timeout signal [S3], converge on the pile, determine who has possession (MOFO 6.10) and encourage players to unpile safely.
3. If you're not the nearest official to the dead-ball spot, observe for late hits and other illegal acts.

Particular types of run play:

4. On a pitchout option play to your side of the field:
 - (a) Move into the backfield to observe action against the trailing back (any offensive player in a position to receive a backward pass), until the ball is pitched or the quarterback turns upfield.
 - (b) If the ball is pitched, you are responsible for the loose ball and for action by and against the trailing back.
 - (c) If the ball is not pitched, once the quarterback turns upfield they are your responsibility as on any other running play, and the Referee (or Centre Judge) will take over responsibility for the trailing back.

General tips:

5. It is better to pick up the ball carrier too soon than not soon enough. You may be forgiven for missing a hold, but you will never be forgiven for missing a fumble.
6. Even though the ball may be on the other side of the field, you may have a better view of the end of the run than the nearest official. If the ball carrier is facing you, or has the ball in the hand nearest you, or is spun round towards you in the tackle, you may need to help out your colleague.
7. If you are the Coverer and the run ends near to the line to gain, you must come in all the way and place a ball at the *exact* dead-ball spot.

13.4 - Pass plays**13.4.a – Priorities**

1. Ruling whether the pass is complete or incomplete. While primarily this will be for passes to your side of the field, in practice you may need to rule on any pass where the receiver is facing or at right angles to you, regardless of their position. Similarly, if the receiver has their back to you, you may need to defer to another official with a better view than you.
2. Observing the initial contact by and against your key player(s).
3. Observing fouls by all players generally in your area, but particularly:
 - (a) defensive and offensive pass interference
 - (b) defensive holding and illegal use of hands against eligible receivers
 - (c) illegal block below the waist fouls by players on your side of the formation
 - (d) illegal touching of a forward pass by a player who went out of bounds voluntarily
 - (e) ineligible receivers downfield
 - (f) **illegal passes**
 - (g) contacting an opponent with the crown of the helmet or targeting a defenseless opponent above the shoulders
 - (h) safety-related fouls such as face mask, tripping, chop blocks or illegal blind-side blocks
 - (i) late hits by any player after the ball is dead
4. Ruling whether a forward pass was thrown from behind or beyond the neutral zone. Also, being prepared to assist in determining whether the ball crossed the neutral zone prior to a forward pass.
5. Ruling whether a forward pass crossed the neutral zone or not.

6. Ruling whether a *quick* quarterback pass went forward or backward. Use the backward pass signal [Sup5] immediately if the pass is backward. Do not attempt to make a pass/fumble ruling if the passer is contacted – leave that to the Referee or Centre Judge. §
 7. Marking the forward progress or out of bounds spot (on your side of the field) if the ball becomes dead behind the neutral zone.
 8. Advising the Referee if the pass was thrown into an area not occupied by an eligible receiver, or the pass clearly did not reach the neutral zone.
 9. Watching for players who go out of bounds across the sideline or end line.
- Once the pass is complete, apply the same priorities as on a running play (above).

13.4.b – Response to what happens (movement and signals)

1. Your progression on a pass play is: (phase A) your key player; (phase B) your zone; (phase C) the destination of the pass. See also Chapter 16.
2. Remain on the line of scrimmage (or take one step into the offensive backfield) to be able to rule on whether a pass was thrown from behind or beyond the neutral zone, and whether or not the pass crossed the neutral zone. Remain there until you are confident a pass is *going to be*[◊] thrown that will definitely cross the neutral zone, then move downfield (typically sidestepping for a short pass; if necessary turning to sprint for a long pass) to get into position to observe the likely destination of the pass, but *(importantly)*^² without getting ahead of the intended receiver.
3. Only watch your key player during the initial action after the snap when there is a threat of illegal contact between receiver and defender. Switch to zone coverage as soon as that threat no longer exists.
4. If a potential Team A receiver voluntarily goes out of bounds in your area, drop your bean bag or hat to indicate this, and observe them to see whether they touch a forward pass while still ineligible.
5. Once you are aware that the pass has been thrown, move into position to best be able to rule on whether the pass is complete or incomplete, and whether there is interference. While the ball is in flight, watch opposing players who are contesting for the ball, not the ball itself. Be alert to both offensive and defensive pass interference.
6. If the player who attempts to catch the ball has their back to you, before making the call, look for help from any official in a better position than you.
7. If the receiver is driven back, be prepared to give them their forward progress. This is especially the case when the receiver is near a sideline, and you may need to use cross-field mechanics. If the receiver is on your side of the field, the other wing official may have the best forward progress. Take your spot from them. If the receiver is on the other side of the field, you may have the best spot. Offer a spot to your colleague. *[USING O2O/CREW RADIO] is one way of doing this, particularly if they are looking away from you (MOFO 25.5.1).* §
8. If you are not the nearest official, don't just watch the receiver, but particularly watch for defenders slightly away from the ball who come in and target the receiver with the crown of their helmet or above the shoulders. This is often missed by the nearest official.
9. If the pass is overthrown, bounces off a player or is otherwise uncatchable, continue to watch the player(s) for personal fouls (hitting a defenseless receiver). Do not ball-watch.
10. Blow your whistle if you see the ball become dead in your area.
11. If the pass is thrown to the opposite side of the field from you, your first responsibility is to clean up action on your side of the field and in the middle of the field. However if you are 100% sure of what you see over there, you may assist with rulings on complete/incomplete, pass interference, illegal helmet contact and forward progress.
12. When ruling on pass receptions involving the sideline, give only one signal *after the ball is dead.* ◊ Give the incomplete pass signal [S10] if *you or another official rules the pass*^² incomplete. Give the timeout signal [S3] if the pass is ruled complete and the ball carrier goes out of bounds thereafter (MOFO 6.8) or the ball is dead at or beyond the line to gain. Give the start the clock signal [S2] if the pass is complete and *you declare the ball carrier down inbounds*^² short of the line to gain *within approximately 10 feet of the sideline.* § Whichever signal is used, *give it*^² two or three times to maximise the chances of other officials seeing it. Remember to look at the other official on your sideline before giving any signal that indicates a completed pass. Nod your head "yes" to them to indicate a completed pass. Give the incomplete pass signal [S10] if you have it incomplete.
13. When contact that would have been pass interference occurs on a pass that is uncatchable, give the uncatchable pass signal [S17].
14. If there is an issue as to whether the pass or passer crossed the neutral zone or not, give the side of the zone signal [Sup42] towards the appropriate side. Maintain/repeat the signal until relevant other members of the crew have seen it.
15. After an incompleteness, obtain a ball from the ball person and form a relay to return the ball to the Spotter (MOFO 6.7).
16. If there is a run after the catch, respond as you would on a running play (above).
17. Maintain a position where you can see player activity in fringe areas, particularly on wide-open plays.

13.4.c – Advanced techniques

1. When an airborne player attempts to catch a pass near the sideline or end line, watch their feet first to see whether they come down in bounds. If they do, then look to their hands to see whether they have control of the ball. If you look at their hands first, you may miss the instant when their foot touches the ground (MOFO 5.4.8). Establish eye contact with any colleague at the end of the play before giving any signal.
2. Always be prepared to come back to rule on play near the neutral zone in addition to sideline action. If the potential passer decides to run with the ball, you must cover them once they are beyond the neutral zone.
3. If the pass is incomplete in your area:
 - (a) If there is no eligible receiver in the area, and/or the pass clearly does not reach the neutral zone, move quickly towards the Referee to inform them of this. If the ball crossed the neutral zone, give signal [Sup42] by pointing to the ground beyond the neutral zone. If the ball did not cross the neutral zone, move towards the Referee while pointing to the ground behind the neutral zone.
 - (b) If there *is* a receiver in the area, and you believe the Referee may not be aware of that fact, move towards the Referee while pointing towards the eligible receiver. Calling out "Number 34 was in the area of the pass" (for example) is also permissible.
 - (c) [USING O2O/CREW RADIO] Transmitting this information is also an option.
4. If you observe the pass being tipped, give the ball touched signal [S11]. The signal should normally be used on passes tipped in the offensive backfield, but inconspicuous (to the spectators) touching downfield could be signified in this way too. It is not necessary to give it when the pass is obviously touched (e.g. when a defensive lineman bats it into the ground).
5. If the play ends near to the line to gain, you must come in all the way and place a ball at the *exact* dead-ball spot.

13.5 - Goal line plays

13.5.a – Priorities

Same priorities as on other scrimmage plays, plus:

1. [AT TEAM B'S GOAL LINE] Ruling whether a touchdown is scored or not.
2. [AT TEAM A'S GOAL LINE] Ruling whether a safety is scored or not.
3. Observing players' celebrations after a score.

13.5.b – Initial positioning

1. Take normal scrimmage down position **2 yards out of bounds or wider[†]** so that you will not be trapped by a quick wide play.[×]
2. You have primary responsibility for Team B's goal line if the ball is snapped from on or inside Team B's 7-yard line.
3. You have primary responsibility for Team A's goal line if the ball is snapped from on or inside Team A's 5-yard line.

13.5.c – Response to what happens (movement and signals)

1. If you have responsibility for either team's goal line, *immediately* after the snap, move directly towards it to rule on the score or an accurate forward progress.
- [AT TEAM B'S GOAL LINE]
2. On a running play, you must be at the goal line before the ball carrier to rule on whether the ball penetrates the plane. Do *not* move towards Team A's backfield to let players pass you.
 3. If you see the ball carrier is stopped short of the goal line, blow your whistle, come in and sell the dead-ball spot. If appropriate, call out "short" to tell your colleagues that.
 4. On a pass play, move immediately to the goal line then respond to the play. If the pass is thrown short of the goal line, remain on the line to rule on penetration of the plane. If the pass is thrown into the end zone, move to the best position to rule on the end of the pass.
 5. Indicate a score by blowing your whistle and giving the touchdown signal [S5] only when you clearly see the ball break the plane of the goal line in player possession or if you see a pass completed in the end zone.
- [AT TEAM A'S GOAL LINE]
6. [SNAP FROM ON OR INSIDE TEAM A'S FIVE-YARD LINE] Be prepared to move back to the goal line to rule on a possible safety. **Assist the Referee (and/or Centre Judge) if Team A's goal line pylon is threatened on your side of the field.**[§]
 7. Indicate a safety by blowing your whistle and giving the safety signal [S6] only when you clearly see the ball carrier down or out of bounds behind the goal line.
- [AT EITHER GOAL LINE]
8. If a pile-up forms at the goal line, come into the field of play until you can see the ball. If you are the nearest official, you may need to dig for it. Check with other officials that they did not see the ball carrier down (or fumble the ball) before **the ball[‡]** reached the goal line.
 9. If you have goal line responsibility and it is necessary to move out of the players' way as they come towards you, move wider without leaving the goal line.

10. Do not give a score signal if you have thrown a penalty flag for a foul by the scoring team. Do not blow your whistle or give any signal if you are not sure about the outcome of the play.
11. If you have goal line responsibility, straddle the goal line – don't run after the player into the end zone unless there is a threat of trouble by or against them, but do turn to keep your eyes on them to observe late hits or unsportsmanlike conduct.
12. If another official has sideline responsibility, do not signal touchdown until you have confirmed with them that the ball carrier was not out of bounds.
13. Maintain the touchdown or safety signal until you know the Referee has seen it, but keep your eyes on the players – don't look to the Referee until all action has ceased. Don't run and signal at the same time. You should not echo the signals of other officials unless the Referee cannot see their signal.
14. It is especially important on goal line plays that all covering officials indicate the same point of forward progress. Communicate if in doubt. Signal only if sure.

13.5.d – Advanced techniques

1. [LINE JUDGE] Inform the deep officials of the number of the yard line that is the line of scrimmage. Communicate (preferably verbally) as to who has the responsibility for the goal line. In noisy situations, point at the line you have responsibility for.
2. On a running play towards the goal line pylon, give priority to ruling on the goal line over ruling on the sideline. The deep wing official on your side can help with the sideline – only you can rule on the goal line.
3. In 3rd and 4th down short yardage situations, treat the line to gain as you would the goal line. **On 3rd down, be prepared to move directly to the line to gain if it is less than 3 yards from the previous spot. Unless a kick is likely, on 4th down, be prepared to move directly to the line to gain if it is less than 4 yards from the previous spot.** †
4. If the line to gain is near the goal line, your first priority is the goal line. If necessary come back from the goal line to the line to gain once it is clear that the ball carrier is unlikely to score. Usually, if the ball carrier only looks like getting as far as the line to gain, then that is the place to be. If the ball carrier is running free and looking able to get near the goal line, that is the place to be.
5. [SNAP FROM OUTSIDE TEAM A'S 5-YARD LINE] Decide whether to go back to Team A's goal line or not based on whether the play is to your side of the field and how likely it is that the ball becomes dead near the goal line. (There is little point in going back if there is a low risk of a Team A player being tackled for a safety.)
6. Do not remain on the line of scrimmage as you would for a pass play elsewhere in the field. The Umpire should assist with passes crossing the neutral zone in goal line situations.
7. **In "hail mary" situations (i.e. a few seconds to go in either half and Team A will likely throw the ball to the end zone), use goal line mechanics regardless of where on the field the ball is snapped.** §

13.6 - Returns

13.6.a – Priorities

1. Observing the ball carrier and action around them while you are the nearest official.
2. Marking the forward progress or out of bounds spot if:
 - (a) the ball becomes dead on your side of the field between Team A's 2-yard line and the goal line; or
 - (b) the ball carrier is between you and Team A's goal line; or
 - (c) you are closer to the spot than the deep wing official.
 Normally the deep wing official will have an easier route to the spot than you because they are following the play while you have still to avoid players running towards you.
3. Observing any fumble where you are the nearest official or have the best view, and marking the spot with a bean bag.
4. Observing blocks by players in your area of responsibility ahead of and around the ball carrier, particularly:
 - (a) illegal block in the back and holding fouls at the point of attack
 - (b) illegal block below the waist fouls anywhere
 - (c) safety-related fouls such as face mask, tripping, chop blocks or illegal blind-side blocks
 - (d) assisting the runner
 - (e) contacting an opponent with the crown of the helmet or targeting a defenseless opponent above the shoulders
 - (f) late hits by any player after the ball is dead
5. Observing any *legal*^o hand-off or pass where you are the nearest official or have the best view, and marking the spot with a bean bag.
6. Observing any *illegal* forward pass or forward handing, especially if you have a view that is level or nearly level with the ball carrier.

13.6.b – Response to what happens (movement and signals)

1. Keep out of the players' way.
2. Backpedal towards Team A's goal line ahead of the play. If it is no longer possible to backpedal, turn and watch the play over your shoulder.
3. If the play advances far enough to threaten Team A's goal line, be there before the ball carrier.
4. Observe the ball carrier while they remain in your area of responsibility. If the change of possession occurs deeper downfield than you are, backpedal down the sideline, always keeping the ball carrier in front of you. Try and keep them boxed in between you and the deep wing official. Take over responsibility for the ball carrier if they overtake you (unless the deep wing official is forced to as well). Stay wide enough to be able to retreat outside the sideline ahead of the players. Never turn your back on the ball.
5. Assist the Referee on Team A's goal line and (if necessary) end line. You have sideline responsibility from your position to the goal line and end line.
6. If you are watching a block develop, stay with it before switching to the ball carrier or another block. Even if you expect another official to take responsibility for it, stay with the block until you are confident it is legal.
7. If the ball becomes dead in your area of responsibility, blow your whistle, give the timeout signal [S3], and then signal first down [S8] to show which team is in possession. You may need to cover dead ball spots between you and the deep wing official if you are considerably closer than they or if their progress to the dead ball spot is delayed. Hold the signal until you know the Referee has seen it.

13.7 - Punts**13.7.a – Priorities**

Before and during the kick, applying the same priorities as on basic scrimmage plays (above), plus:

1. Ruling whether the kick crosses the neutral zone by knowing if it touches the ground, a player or official beyond the neutral zone.
2. If the kick is short:
 - (a) Marking the end of the kick (if inbounds) with a bean bag.
 - (b) Marking the dead-ball spot for any kick that goes out of bounds in your area.
 - (c) Ruling whether players touched the ball or not.
 - (d) Observing any fair catch signals by players in your area.
 - (e) Observing kick-catch interference against a player in position to catch the kick, if the kick comes down in your area.
 - (f) If the kick does not come down in your area, observing players who have *not* committed kick-catch interference because they were blocked by an opponent into the returner.
 - (g) Marking all spots of illegal touching with a bean bag.
3. Observing fouls by all players generally in your area, but particularly:
 - (a) illegal blocks below the waist, especially by players on your side of the field and [DOWN JUDGE] the up back
 - (b) before the kick, illegal block in the back and holding fouls by linemen and backs protecting the kicker, especially the tackle or wing back on your side
 - (c) during the kick, illegal block in the back and holding fouls against Team A players trying to get down the field
 - (d) a Team A player returning inbounds after voluntarily going out of bounds during the down (dropping² your bean bag or hat to mark their exit, and your flag if they return)
 - (e) kick catch interference when the kicked ball will land in your area
 - (f) illegal blocks made by players who have signalled for a fair catch
 - (g) contacting an opponent with the crown of the helmet or targeting a defenseless opponent above the shoulders
 - (h) safety-related fouls such as face mask, tripping, chop blocks or illegal blind-side blocks
 - (i) unnecessary roughness fouls away from the ball
 - (j) late hits by any player after the ball is dead
4. Noting the numbers of players in eligible receiver positions on your side of the formation, and observing whether anyone else is the first to touch the ball or is ineligibly downfield if the play develops into a pass play.
5. Responding to bad snaps or blocked kicks by adopting run, pass or return priorities, as appropriate.

During the punt return, applying the same priorities as on returns (above).

13.7.b – Initial positioning

1. Take normal scrimmage down position.
2. [IN xx3 FORMATION (CREW OF 7/8)] The Back Judge will have responsibility for the end of the kick, unless it ends very close to a sideline or the Back Judge is well out of position,[§] in which case it is the responsibility of the nearest sideline official.
3. [IN xx2 FORMATION (CREW OF 6D)] The Field Judge is responsible for the deepest returner and kicks that end near them, and the Side Judge is responsible for all shallower returners except those near the Line Judge. If there are two deep returners, the Field Judge and Side Judge each take responsibility for their

nearest returner and kicks that end near them. If there are more than two, the Field Judge will normally take responsibility for the two nearest them. The Field Judge and Side Judge always work from the outside in.

4. The deep wing officials will normally be responsible for the returners, but the [wing officials](#) must assist on their respective sides of the field with coverage of the shallowest returners and short kicks out of bounds.

13.7.c – Response to what happens (movement and signals)

1. When the ball is kicked, observe its initial trajectory, but do not watch the flight of the ball. Observe players in your area of responsibility (defined by the diagrams in section 26.4) – their eyes will tell you where the ball is going. However, if the returner moves as a decoy, do not follow them - observe the area where the ball will come down.
2. Stay on the line of scrimmage until the ball crosses the line, then move downfield after the players until you are approximately 15-20 yards ahead of the return. Backpedal to stay ahead of the returner as they approach your position.
3. When it appears obvious that the kicked ball will *not* land in your area:
 - (a) Maintain a position where you can cover action in front of and around the returner. If you are the nearest official *other than* the official covering the punt returner, move to where you can observe players blocking in the vicinity of any returner who is in position to catch the kick. In particular, observe those *blocked by an opponent* into interfering and therefore immune to penalty (Rule 6-4-1-d).
 - (b) If a player in your area signals for a fair catch, watch that they do not block before they touch the ball (Rule 6-5-4).
 - (c) Do not hesitate to call a foul if you clearly see one occur in the area where you are the cleanup official even though you may be a considerable distance away from the action. Communicate with your colleagues to find out their view of the action.
4. When it appears obvious that the kicked ball *will* land in your area:
 - (a) If the kick is first muffed (but not possessed) by a member of Team B beyond the neutral zone, you may give the ball touched signal [S11] to signify that Team A is now eligible to touch it.
 - (b) Use bean bags to mark any spots of illegal touching and/or the spot where the kick ends. Only one official, the Coverer in each case, should mark each spot and give each signal. If you have more spots than bean bags, prioritise the spot most advantageous to Team B.
 - (c) If the ball becomes dead because it is caught or recovered by Team B after a fair catch signal, or caught or recovered by Team A after being touched by Team B, blow your whistle and give the timeout signal [S3]. Give the first down signal [S8] in the appropriate direction.
 - (d) If the kick is recovered by Team A without it being touched by Team B, blow your whistle, signal timeout [S3] and give the illegal touching signal [S16] and the first down signal [S8]. Momentary touching of the ball by a player of the kicking team should not be interpreted as control of the ball.
 - (e) If the kick goes out of bounds in your area, blow your whistle and signal timeout [S3] immediately.
 - (i) If the ball touches anything (e.g. the ground or a player) in bounds and then goes out of bounds, move directly to the spot where you judge the ball crossed the sideline.
 - (ii) If the ball goes out of bounds in flight, the Referee or Centre Judge *may* be able to assist by directing you to the spot. Look back to the Referee or Centre Judge to see if either can help. If either can, signal [Sup16] and respond to the instructions they give you using signals [Sup17, Sup18 & Sup19] to direct you to the crossing point. If they can't, move directly to the spot where your best judgement tells you the ball crossed the sideline.
 - (iii) Hold the spot, but do not place a ball at it unless a spare is at hand. Other officials will retrieve/relay a ball to the Spotter.
 - (f) If the ball rolls to a stop in your area, ensure no player is attempting to recover it before blowing your whistle and signalling timeout [S3].

During the punt return, respond as in the section "Returns" (above).

13.7.d – Advanced techniques

1. Be alert for cases where the kick is blocked or where there is a bad snap. This also applies if Team A switches to a run or pass formation.
 - (a) If the play turns into a run or pass, respond as you would do normally for that type of play.
 - (b) Cover the goal line and end line as appropriate ([see the section in this chapter on "Goal line plays"](#)).^λ
 - (c) Be aware of the jersey numbers of the eligible receivers.
 - (d) If the kick is blocked or the snap is loose in the backfield, hold your position on the line of scrimmage until you can read the play. If the play is to your side of the field, move into Team A's backfield to assist the Referee and to reach a place for your own safety. If the play is [to the other side or middle](#)^λ of the field, stay on the line of scrimmage at least until it becomes extremely unlikely that a kick will cross it.
 - (e) [\[IN 2xx FORMATION \(NO C\)\] Assist](#) the Referee by observing actions against the kicker, especially when the ball is on the opposite side of the field. [The Referee will have switched their responsibilities to watching the ball.](#)[◊]

13.8 - Field goal & try attempts

13.8.a – Priorities

Before and during the kick, applying the same priorities as on basic scrimmage plays (above), plus:

1. Ruling whether the kick crossed the neutral zone, by knowing if it touches the ground, a player or official beyond the neutral zone.
 2. Observing fouls by all players generally in your area, but particularly:
 - (a) illegal block in the back and holding fouls by linemen and backs protecting the kicker and holder, especially the end and/or wing back on your side
 - (b) illegal blocks below the waist
 - (c) contacting an opponent with the crown of the helmet or targeting a defenseless opponent above the shoulders
 - (d) safety-related fouls such as face mask, tripping, chop blocks or illegal blind-side blocks
 - (e) unnecessary roughness fouls away from the ball
 - (f) late hits by any player after the ball is dead
 - (g) illegal formation
 3. Noting the numbers of players in eligible receiver positions on your side of the formation, and observing whether anyone else is the first to touch the ball or is ineligibly downfield if the play develops into a pass play.
 4. Responding to bad snaps or blocked kicks by adopting run, pass or return priorities, as appropriate.
- If the kick is returned, applying the same priorities as on returns (above).

13.8.b – Initial positioning

1. Be in normal scrimmage down position.
2. **[DOWN JUDGE]** On a try down, set the down box on the three-yard line showing down 1, and instruct the chain crew to lay the chain on the ground outside the **safety zone**[®] at around the 20-yard line, and to stand well back.

13.8.c – Response to what happens (movement and signals)

1. After the kick, jog in towards the pile of players in the middle of the field. This will force you to keep your eyes on the players and discourage you from looking to see if the kick is good or not. If trouble occurs, you will be in a better position to assist the Umpire in dealing with it.

13.8.d – Advanced techniques

1. Be alert for blocked kicks and their recovery and advance. On fake kicks switch to normal run or pass coverage.
 - (a) If the play turns into a run or pass, respond as you would do normally for that type of play, bearing in mind that other officials may not respond as quickly as you. If the Field Judge and Side Judge are not in a position to do so, you may need to get to your goal line pylon as quickly as possible.
 - (b) **Note the numbers of the (normally) two eligible receivers on your side of the offensive formation so that, if a pass develops, you can rule on ineligibles touching a pass or being illegally downfield.**
 - (c) If the kick is blocked or the ball is loose in the backfield, hold your position on the line of scrimmage until you can read the play. If the play is to your side of the field, move into Team A's backfield to assist the Referee and to reach a place for your own safety. If the play is **to the other side or middle**² of the field, stay on the line of scrimmage at least until it becomes extremely unlikely that a kick will cross it.
 - (d) **[IN 2xx FORMATION (NO C)] Assist** the Referee by observing actions against the kicker and holder, **especially when the ball is on the other side of the field.** The Referee will have switched their responsibilities to watching the ball.
2. **[LINE JUDGE]** On a try down, instruct the alternate line-to-gain marker operator (if you have them) to lay their equipment on the ground and to stand well back.

13.9 - After each down

13.9.a – Priorities

1. Observing dead-ball action by players of both teams.
2. Encouraging the players to unpile safely, and either return the ball to an official or leave it near the dead-ball spot, as appropriate.
3. Checking whether the line to gain has been reached or is close, and signalling appropriately.
4. Checking whether any penalty flags have been thrown, and, if so:
 - (a) Giving the timeout signal [S3].
 - (b) Reporting any fouls you have called to the Referee and Umpire.
 - (c) Covering penalty flags (and bean bags, if appropriate) thrown by colleagues.
 - (d) Ensuring that all penalties are enforced correctly.
 - (e) Keeping the Head Coach on your sideline informed of penalties, particularly against their team.
5. Checking for injured players or other occurrences that may delay play.

6. [ON-FIELD TIMEKEEPER] Stopping and starting the clock when necessary.
7. Allowing legitimate requests for timeouts. Checking that a request coming from the coaching box or team area was made by the Head Coach.
8. Echoing all timeout signals [S3] of your colleagues.
9. Knowing whether the play ended inbounds, and informing the Referee that the clock (if stopped) should start on the ready by giving them the clock running signal [Sup12].
10. Assisting in relaying the dead ball or a new ball to the succeeding spot.

13.9.b – Initial positioning

1. Shortly after the end of the previous down, you should be in a position level with the succeeding spot.

13.9.c – Response to what happens (movement and signals)

1. If you are the Coverer, check whether the line to gain has been reached. [LINE JUDGE] You should normally be in a particularly good position to rule on this. If you do this consistently, the [Down Judge](#) will not need to turn to look at the chains to know whether the line to gain has been reached.
 - (a) If it has, give the timeout signal [S3]. After all action has ceased, signal first down [S8 or Sup35]. Hold the signal until you know the Referee is aware of it.
 - (b) If you are not sure whether the line to gain has been reached or not, signal timeout [S3] and yell "close". Encourage the Referee to come and look for themselves.
 - (c) Only place a ball on the ground at the *actual* dead-ball spot – never at a spot level with it.
 - (d) If the play ended inbounds, inform the Referee that the clock should start on the ready by giving them the clock running signal [Sup12].
2. If you are the Coverer, [give only one signal that the ball is dead](#). See paragraph 6.5.14. [‡]
3. If a penalty flag has been thrown follow the procedure in Chapter 19. [If an inadvertent whistle has been blown, follow the procedure in Section 6.15.](#) [§] If a team or injury timeout has been called, follow the procedure in Chapter 17. If a period has ended, follow the procedure in Chapter 20.

Moving the down box and chains:

4. [DOWN JUDGE]
 - (a) When certain that there has been no foul on the previous play (and that there is no other reason to wait), instruct the down marker to be moved to the new position, and check that the correct down number is displayed.
 - (b) When a first down is achieved, and a new line to gain is to be established, first instruct the down marker to be moved to the new position on the sideline. The chain crew should then be instructed to move quickly to their new positions.
 - (c) Anticipate any call for a measurement and be ready to bring in the chains when signalled by Referee.
5. [LINE JUDGE]
 - (a) Anticipate any call for a measurement and be ready to come in to mark the spot for the clip when signalled by the Referee.

Relaying the ball:

6. If you have the ball, but another official has the dead-ball spot and it is close to the line to gain, hand the ball to that official and allow them to spot it at the precise location (yard line *and* lateral position) where the ball became dead.
7. Unless you are the Coverer, assist in relaying a ball to the official who will place it at the succeeding spot (MOFO 6.7).
8. If a ball has been placed at the dead-ball spot in a side zone, and another ball is being relayed in to the succeeding spot, do not move the ball at the dead-ball spot until the replacement ball has been positioned at the correct location [at the inbounds spot](#). [‡]

Getting ready for the next down:

9. Check that there is nothing untoward going on outside your sideline or in your team area, but don't allow this duty to detract from your primary responsibilities within the field of play.
10. Verbally or visually (using signals [Sup11] or [Sup12]) inform the Referee of the correct down and clock status (if you are the Coverer), and check that the Referee indicates it correctly. Inform them immediately if an incorrect signal is given. Be aware of the new distance to the line to gain.
11. [ON-FIELD TIMEKEEPER] Remind the Referee of the clock status and, if stopped, remind them whether it should start on the snap or on the ready.
 - (a) If the clock has stopped for a foul, injury or helmet coming off and there is less than **two minutes**[®] in the half, make sure the Referee knows that there is a possible 10-second runoff.
 - (b) Be prepared for a ruling by the Referee on when the clock should start in unfair clock tactics situations.
 - (c) Start the clock when the Referee gives (or should give) the start the clock signal [S2], unless you are sure that by rule the clock should start on the snap, or the ball is obviously not ready for play (e.g. because ball, chains, down box or officials are not in position). Do *not* echo the Referee's signal, but use the clock-on-ready signal [Sup12] if necessary to confirm that the clock has started.
 - (d) If the game clock should start on the snap, start it when you see the ball legally snapped. There is no need to give a signal to confirm this.

- (e) Your primary responsibility is to get the time accurate by rule, not to follow erroneous Referee's signals about time (**Exception:** unfair clock tactics situations), but work together to get things right (MOFO 6.12.4).[§]
12. If there are stadium game clocks, check to see that they have stopped and started correctly.
 13. If substitutions are made from your side of the field, check that Team A players fulfil the nine-yard mark requirements (Rule 7-1-3-b).
 14. Move into position for the next down. If the ball is ready for play (or will be imminently), backpedal to keep your eyes on the ball. Do not take your eyes off it for long in case the play starts while you are not looking.

13.9.d – Advanced techniques

1. The priority at the end of a play is to get into position ready for the next one. Only if a serious incident occurs (such as a foul or misconduct, an injury, or a breakage of the chain) should your routine be interrupted.
2. If Team A makes substitutions **while the snapper is at, near or moving towards** their position at the line of scrimmage:
 - (a) Any official should be prepared to step in and shut down a play that violates the substitution rule.
 - (b) Give the matching substitutes signal [Sup36] to the Referee and shout "subs on".
 - (c) **Drop the signal when** the Referee has taken control of the process.
3. **Procedures intended to allow the defense to match up must not be used for a substitution for a last-second field goal. In that situation, Team A is making a normal and expected personnel change and Team B should be prepared to respond appropriately. In no case should an official be standing over the ball to prevent the snap as the clock runs out.**[§]
4. If you want to speak to a player on the field (e.g. to warn them that they are close to fouling), it often saves time to relay the message via the Referee or Centre Judge (for a Team A player) or the Umpire or Back Judge (for a Team B player). Don't delay the game unnecessarily by entering either team's huddle, unless a timeout is still in progress. Never attempt to speak to a player during a hurry-up or no-huddle offense.
5. Maintain your concentration, and think about the next play.
6. [LINE JUDGE WHEN THERE IS AN ALTERNATE CREW]
 - (a) When the ball is declared ready for play for the next down, instruct the alternate down box operator to move their box to the new position.
 - (b) When a new line to gain is established and the chain is set, instruct the alternate line-to-gain marker operator to move it to the new position.
7. [DOWN JUDGE] Don't spend so much time interacting with the chain crew that you disregard your other duties watching players and communicating with colleagues.

14. FIELD JUDGE AND SIDE JUDGE (CREW OF 6D/7/8)

14.1 - Free kicks

14.1.a – Priorities

Prior to the kick:

1. Being aware of whether the Referee has instructed the crew to switch to onside-kick positions, and moving position (if appropriate) if they have.
2. Counting Team A players and signalling the count [one of Sup3, Sup4 or Sup24] to colleagues. Noting count signals from colleagues. Recounting if your count differs from that of colleagues.
3. Reminding the players to count their number if the team you are responsible for counting does not have precisely **the correct number of[‡]** players on the field.
4. Checking readiness for play:
 - (a) Checking side areas to ensure that all non-players are out of the restricted areas, that non-participants are off the field of play, **that the safety zone is clear,[®]** and that all team personnel are within the team area.
 - (b) Ensuring that the chain crew (and the alternate down box and line-to-gain marker operators, where provided) have moved themselves and their equipment well out of the way and that the equipment has been placed on the ground outside the team areas and **outside the safety zone[®]** at the receiving team's end of the field. Checking that the ball persons are in position.
 - (c) Ensuring that all Team A players **have been within the nine-yard marks after the ready for play and prior to the kick,[‡]** (Rule 6-1-2-c-5) and that nobody other than the kicker is more than five yards behind the ball.
 - (d) Facing the field of play to signal that you are ready. Turning away, **or obviously leaving your position,[°]** if something on your sideline becomes no longer clear or you can see that a colleague is clearly not ready. Sounding your whistle, if your area becomes dangerously unclear after the ready for play.
5. Being alert always for short kicks.

During the kick play:

6. Observing whether a free kick goes out of bounds nearest to you without being touched by the receiving team. Ruling whether a Team B player near the sideline touches the ball while out of bounds.
7. Watching players for a fair catch signal, and being prepared to rule on any interference with the opportunity to catch the kick.
8. If the kick is short:
 - (a) Knowing where and by whom the ball was first touched.
 - (b) If you are positioned on Team B's restraining line, knowing whether the kick breaks the plane of that line.
 - (c) Observing illegal blocks by Team A (Rule 6-1-12).
 - (d) Marking any spot of illegal touching with a bean bag.
 - (e) Marking the dead-ball spot if you are the nearest official and there is little or no return run.
9. Giving the start the clock signal [S2] only if the ball is first legally touched in the field of play **and you are the nearest official or you have the best view of it.**
10. Marking the dead-ball spot if you are the nearest official when the ball carrier is tackled or goes out of bounds.
11. Ruling a touchdown at Team A's goal line.
12. Observing fouls/violations by all players generally in your area, but particularly:
 - (a) illegal touching of a short kick
 - (b) infractions of your restraining line
 - (c) [WHEN ON TEAM A'S RESTRAINING LINE] kicking team players (other than the kicker) more than 5 yards behind their restraining line after the ready for play
 - (d) illegal blocks in the back and holding fouls at the point of attack
 - (e) illegal blocks below the waist
 - (f) contacting an opponent with the crown of the helmet or targeting a defenseless opponent above the shoulders
 - (g) safety-related fouls such as face mask, tripping, chop blocks, illegal wedges or illegal blind-side blocks
 - (h) late hits by any player after the ball is dead
 - (i) any player of the kicking team who enters the field of play after the kick or who voluntarily goes out of bounds during the kick and returns inbounds
 - (j) **illegal forward handing or illegal forward passes**

14.1.b – Initial positioning**Normal kicks:**

1. If the free kick takes place after a score, proceed along the sideline to your kickoff position, ensuring as you do so that the team on your side of the field is aware of the progress of the one-minute intermission (Rule 3-3-8-f).
2. [FIELD JUDGE]
 - (a) [IN F6 FORMATION (CREW OF 6)] Be in position F (see 26.1) outside the press box sideline on Team A's restraining line.
 - (b) [IN F7-8 FORMATION (CREW OF 7/8)] Be in position D (see 26.1) outside the press box sideline on Team B's restraining line.
3. [SIDE JUDGE] Be in position E (see 26.1) outside the sideline opposite the press box on Team B's restraining line.

Onside-kicks:

4. [FIELD JUDGE] Remain in the normal position.
5. [SIDE JUDGE]
 - (a) [IN F6-7 FORMATION (CREW OF 6/7)] Move to position G (see 26.1) outside the sideline opposite the press box on Team A's restraining line [as the Down Judge moves into your normal position.](#) [◇]
 - (b) [IN F8 FORMATION (CREW OF 8)] Remain in the normal position.

Free kicks after a penalty or safety:

6. When a free kick is taken following a penalty or a safety, the same relative positions should be taken, moving up or down the field as appropriate.

14.1.c – Response to what happens (movement and signals)**Prior to the kick:**

1. If anything happens that should prevent the kick taking place (e.g. a non-player enters or approaches the field of play), toot your whistle, give the timeout signal [S3] and deal with the problem.

During any kick play:

2. If you see any player of the kicking team voluntarily go out of bounds during the kick, drop your bean bag or hat to mark their exit, and your flag if they return.
3. If the clock should start when the ball is first legally touched in the field of play, give the start the clock signal [S2] if you are the nearest official or the one with the best view.

During a kick play that goes deep:

4. After the ball is kicked, observe the players in your area of responsibility (see 26.1). After checking its initial trajectory, do not watch the flight of the ball.
5. Move downfield along the sideline while the kick is in the air. During the return, stay ahead of the ball carrier, keeping them [boxed in](#)² between you and the downfield official. On a long run, be at Team A's goal line before the ball carrier. [You have shared responsibility for the goal line.](#) [◇] Mark the dead-ball spot if you are the nearest official when the ball carrier is tackled or is out of bounds.
6. If the ball goes out of bounds in your area, go to and hold the spot, dropping your flag if appropriate.

During a kick play where the kick is short:

7. Maintain a position where you can see the ball and the blocks by Team A players.
8. [IF ON TEAM A'S RESTRAINING LINE] Particularly [observe](#)² the blocks made by Team A players before they are eligible to touch the ball (Rule 6-1-12).
9. [IF ON TEAM B'S RESTRAINING LINE] Know where and by whom the ball was first touched. Mark any spot of illegal touching with your bean bag (Rule 6-1-3).
10. If you are the nearest official when the ball becomes dead, signal timeout [S3] and mark the dead-ball spot.

14.1.d – Advanced techniques

1. Pay particular attention to the blocks made by the two players from Team B's front line who were nearest you at the kick.
2. [IN F6-7 FORMATION (CREW OF 6/7)] [SIDE JUDGE]
[IN F6 FORMATION (CREW OF 6)] [FIELD JUDGE] If an expected onside kick is instead kicked deep, move into the field of play and leave sideline responsibility in your area to the [Down Judge](#) / Line Judge.
3. [After the ball is dead and all action is ceased, if you are the nearest official to the previous spot make sure that any kicking tee has been removed from the field.](#) [◇]

14.2 - Basic scrimmage plays**14.2.a – Priorities**

1. Knowing the down and distance, and signalling the down to your colleagues. Noting the down signals given by colleagues. Checking that the down box displays the correct number. Not allowing play to start if there is a dispute about the down number.
2. Counting Team B players and signalling the count [one of Sup3, Sup4 or Sup24] to your colleagues. Noting count signals from colleagues. Recounting if your count differs from that of colleagues. [SIDE JUDGE] [Exception: you do not have this responsibility if you are in a double-umpire position.](#) [◇]

3. [ON-FIELD PLAY CLOCK OPERATOR] If visible stadium play clocks are being used, observing their start on the Referee's ready, and observing whether they count down to zero before the ball is snapped.
4. Identifying your key player(s) (see sections 16.5 and 16.6). If the formation is new or unusual, verbally or visually confirming this with the other officials.
5. Noting eligible receivers and those players who would normally be eligible by position but who are ineligible by number. In addition, noting players (usually tight ends) who would normally be eligible by number but who are not eligible because a player is lined up outside them on the line of scrimmage.
6. Observing substitution infractions by both teams (especially the team on your side of the field). For example:
 - (a) replaced players not leaving the huddle within 3 seconds of an incoming substitute entering it
 - (b) replaced players not being off the field before the snap
 - (c) substitutes coming on to the field, communicating, and then leaving the field
7. Ensuring that coaches and substitutes are behind the coaching box line and that your sideline is clear of any obstructions.
8. Alerting colleagues if Team A makes a substitution while the snapper is at, near or moving towards their position at the line of scrimmage. §

14.2.b – Initial positioning

1. [SIDE JUDGE] Be on the same side of the field as the Down Judge.
2. [FIELD JUDGE] Be on the same side of the field as the Line Judge.
3. Be in position at least a yard outside the sideline. † Both officials should lineup on the same yard line. [FIELD JUDGE] Match the depth set by the Side Judge, unless the Side Judge is clearly in the wrong position, in which case attempt to correct them. [USING O2O/CREW RADIO] is one way to do this. §
 - (a) Normally be 20-22 yards from the line of scrimmage. If that position would put you between Team B's 5-yard line and their goal line, instead be on the goal line – then you don't have to move to get there.
 - (b) [IN xx3 FORMATION (CREW OF 7/8)] Do not be as deep as the Back Judge.

14.2.c – Advanced techniques

Reasons for varying (or not) your initial position:

1. Your initial position may be varied according to the state of the game. It is appropriate to be deeper if expecting a long pass, and shallower for short-yardage situations.
2. On "take a knee" plays, you may leave the sideline, pinch in closer to the players and use your presence to deter unsportsmanlike acts.

Signalling the player count:

3. The latest time to make the player count signal is when the offensive team breaks its huddle (but it can and should be done earlier if possible).
4. Normally the player count signal is shared between the Field Judge, Side Judge and [IN xx3 FORMATION (CREW OF 7/8)] Back Judge.

14.3 - Running plays

14.3.a – Priorities

1. Observing action ahead of the ball carrier.
2. Ruling whether a touchdown is scored or not.
3. Marking the forward progress or out of bounds spot if the ball becomes dead on your side of the field between Team B's 2-yard line and the goal line.
4. Observing any fumble where you are the nearest official or have the best view, and marking the spot with a bean bag.
5. Observing fouls by all players generally in your area, but particularly:
 - (a) illegal block in the back and holding fouls at the point of attack, especially those made by your key player or any wide receiver, tight end, lead back or pulling lineman
 - (b) illegal block below the waist fouls by your key player and other players in your area
 - (c) safety-related fouls such as face mask, tripping, chop blocks or illegal blind-side blocks
 - (d) late hits by any player after the ball is dead
6. Getting to the goal line ahead of any ball carrier in order to be able to rule on a touchdown.

14.3.b – Response to what happens (movement and signals)

1. If you read that a long run is developing, backpedal down the sideline, always keeping the ball carrier in front of you. Try and keep them boxed in between you and the wing official. Take over responsibility for the ball carrier only if they overtake you (unless the wing official is forced to overtake you as well).
2. Stay wide enough to be able to retreat outside the sideline ahead of the players. Never turn your back on the ball.
3. If the play advances far enough to threaten Team B's goal line, be there before the ball carrier.
4. If the run goes to the opposite side of the field, observe action behind the ball carrier and the Umpire. [IN xx2 FORMATION (CREW OF 6D)] It is permissible to move in to near the hash marks to better observe

players. However, be alert for reverses or a ball carrier cutting back towards your side. If this happens, be sure to be back on or outside your sideline before the ball or ball carrier reaches it.

If the ball becomes dead on your side of the field:

5. Blow your whistle if you clearly see the ball carrier down or out of bounds. If they are out of bounds or the line to gain has been reached, also signal timeout [S3].
6. If you are much closer than the wing official, or the ball becomes dead within 2-yards of Team B's goal line, move to the dead-ball spot once players have cleared the immediate area.
 - (a) If the play ends in bounds, square off, i.e. move parallel to the sideline then in, rather than diagonally.
 - (b) If the play ends out of bounds, mark the forward progress and watch any continuing action in the out-of-bounds area. (The wing official should go out-of-bounds to supervise activity in this area. Exceptionally **you**² could go too, after dropping **your**² bean bag to mark the forward progress.)
 - (c) Be alert to cover the forward progress spot when the ball carrier has been driven back.
 - (d) Do not leap over players to reach the forward progress spot: keep the players in front of you.
 - (e) Once all action has ceased, help retrieve/relay a ball to the Spotter (MOFO 6.7).
7. If the ball carrier goes out of bounds in the wing official's area, go into the team area as far as the ball carrier and observe any actions against them.

14.3.c – Advanced techniques

1. Don't blow your whistle when the ball carrier's back is toward you or you are obscured by other players or officials² – they may have fumbled the ball without you seeing it. See leather! Be certain that the ball is dead.
2. If a pile-up of players forms, give the timeout signal [S3], converge on the pile, determine who has possession (MOFO 6.10) and encourage players to unpile safely.
3. If you're not the nearest official to the dead-ball spot, observe for late hits and other illegal acts. It is particularly your responsibility to observe action close to the wing officials as they are concentrating on the forward progress spot.

14.4 - Pass plays

14.4.a – Priorities

1. Ruling whether the pass is complete or incomplete. While primarily this will be for passes to your side of the field, in practice you may need to rule on any pass where the receiver is facing or at right angles to you, regardless of their position. Similarly, if the receiver has their back to you, you may need to defer to another official with a better view than you.
2. Ruling on touchdowns on passes into the end zone.
3. Observing the initial contact by and against your key player(s).
4. Observing fouls by all players generally in your area, but particularly:
 - (a) defensive and offensive pass interference
 - (b) defensive holding and illegal use of hands against eligible receivers
 - (c) illegal block below the waist fouls by players on your side of the formation
 - (d) illegal touching of a forward pass by a player who went out of bounds voluntarily
 - (e) contacting an opponent with the crown of the helmet or targeting a defenseless opponent above the shoulders
 - (f) safety-related fouls such as face mask, tripping, chop blocks or illegal blind-side blocks
 - (g) late hits by any player after the ball is dead
5. Advising the Referee if the pass was thrown into an area not occupied by an eligible receiver.
6. Watching for players who go out of bounds across the sideline or end line.

Once the pass is complete, apply the same priorities as on a running play (above).

14.4.b – Response to what happens (movement and signals)

1. Your progression on a pass play is: (phase A) your key player; (phase B) your zone; (phase C) the destination of the pass. See also Chapter 16.
2. If you read a short pass, hold your position until the play approaches you. Then or if you read a long pass, backpedal or sidestep down the sideline, always keeping deeper than any potential receiver to your side of the field. If you are forced to turn, keep watching the play by looking back over your shoulder, but that will narrow your field of vision. Ensure that you can see blocking and contact by and against any eligible receivers in your zone of the field.
3. Only watch your key player during the initial action after the snap when there is a threat of illegal contact between receiver and defender. Switch to zone coverage as soon as that threat no longer exists.
4. You have sole responsibility for the sideline from your position to Team B's end line, and joint responsibility for it between you and the wing official. Either of you may declare the ball carrier or ball out of bounds, but unless you are much closer, it should be the wing official who marks the forward progress.
5. Be responsible for the goal line and the end line on your side of the field but do not neglect the middle of the field. [IN xx3 FORMATION (CREW OF 7/8)] The Back Judge will assist you with these.

6. If a potential Team A receiver voluntarily goes out of bounds in your area, drop your bean bag or hat to indicate this, and observe them to see whether they touch a forward pass while still ineligible.
7. Once you are aware that the pass has been thrown, move into position to best be able to rule on whether the pass is complete or incomplete, and whether there is interference. While the ball is in flight, watch opposing players who are contesting for the ball, not the ball itself. Be alert to both offensive and defensive pass interference.
8. If the player who attempts to catch the ball has their back to you, before making the call, look for help from any official in a better position than you.
9. If you are not the nearest official, don't just watch the receiver, but particularly watch for defenders slightly away from the ball who come in and target the receiver with the crown of their helmet or above the shoulders. This is often missed by the nearest official.
10. If the pass is a screen pass (i.e. does not cross the neutral zone), focus on the blocks in advance of the receiver, observing holding and illegal use of hands fouls in that area. §
11. If the pass is overthrown, bounces off a player or is otherwise uncatchable, continue to watch the player(s) for personal fouls (hitting a defenseless receiver). Do not ball-watch.
12. Blow your whistle if you see the ball become dead in your area.
13. If the pass is thrown to the opposite side of the field from you, your first responsibility is to clean up action on your side of the field and in the middle of the field. However if you are 100% sure of what you see over there, you may assist with rulings on complete/incomplete, pass interference, illegal helmet contact and forward progress.
14. When ruling on pass receptions involving the sideline, give only one signal after the ball is dead. ◊ Give the incomplete pass signal [S10] if you or another official rules the pass² incomplete. Give the timeout signal [S3] if the pass is ruled complete and the ball carrier goes out of bounds thereafter (MOFO 6.8) or the ball is dead at or beyond the line to gain. Give the start the clock signal [S2] if the pass is complete and you declare the ball carrier down inbounds² short of the line to gain within approximately 10 feet of the sideline. § Whichever signal is used, give it² two or three times to maximise the chances of other officials seeing it. Remember to look at the other official on your sideline before giving any signal that indicates a completed pass. Nod your head "yes" to them to indicate a completed pass. Give the incomplete pass signal [S10] if you have it incomplete.
15. When contact that would have been pass interference occurs on a pass that is uncatchable, give the uncatchable pass signal [S17].
16. After an incompletion, obtain a ball from the ball person (if the wing official has not already done so), and form a relay to return the ball to the Spotter (MOFO 6.7). Ensure that the thrown ball is removed from the field.
17. If there is a run after the catch, respond as you would on a running play (above).
18. Maintain a position where you can see player activity in fringe areas, particularly on wide-open plays.

14.4.c – Advanced techniques

1. When an airborne player attempts to catch a pass near the sideline or end line, watch their feet first to see whether they come down in bounds. If they do, then look to their hands to see whether they have control of the ball. If you look at their hands first, you may miss the instant when their foot touches the ground (MOFO 5.4.8). Establish eye contact with any colleague at the end of the play before giving any signal.
2. If the pass is incomplete in your area:
 - (a) If there is no eligible receiver in the area, move quickly towards the Referee to inform them of this. If the ball crossed the neutral zone, give signal [Sup42] by pointing to the ground beyond the neutral zone. If the ball did not cross the neutral zone, move towards the Referee while pointing to the ground behind the neutral zone.
 - (b) If there *is* a receiver in the area, and you believe the Referee may not be aware of that fact, move towards the Referee while pointing towards the eligible receiver. Calling out "Number 34 was in the area of the pass" (for example) is also permissible.
 - (c) [USING O2O/CREW RADIO] Transmitting this information is also an option.

14.5 - Goal line plays

14.5.a – Priorities

Same priorities as on other scrimmage plays, plus:

1. Ruling whether a touchdown is scored or not. This includes all passes into the end zone, plus running plays if the ball is snapped outside Team B's 7-yard line.
2. Observing players' celebrations after a score.

14.5.b – Initial positioning

[SNAP FROM BETWEEN TEAM B'S 25 AND 7-YARD LINES]²

1. Be at least 2 yards[†] outside the sideline at the goal line.
2. Check your area for obstacles such as people and the goal line markers. Make sure you are able to move safely outwards on the goal line extended if your pylon is threatened.

3. Be able to see at least half of the goal line, and your sideline in the end zone. When play terminates on or near the goal line you must be on the goal line to rule on penetration of the plane.
4. Be prepared to rule on forward progress within 2 yards of the goal line.
5. [IN xx2 FORMATION (CREW OF 6D)] Also be able to see at least half of the end line.
[SNAP FROM ON OR INSIDE TEAM B'S 7-YARD LINE]
6. [IN xx3 FORMATION (CREW OF 7/8)] Be on the sideline extended, approximately 2 yards beyond the end line. If there is no wideout to your side, it is permissible to move to a position where you are 45-degrees to the sideline extended and end line extended.
7. [IN xx2 FORMATION (CREW OF 6D)] Be approximately 2 yards out of bounds 45-degrees to the sideline extended and end line extended.
8. Be able to observe all action in your area of the end zone, and be especially aware of action close to the sideline or end line. The wing officials will be responsible for the goal line.

14.5.c – Response to what happens (movement and signals)

1. If you have goal line responsibility, remain on the line unless you need to move to a position to rule on a pass completion in the end zone.
2. If you have sideline/end line responsibility, on a running play observe lead blockers and on a pass play observe all receivers in your zone. If a receiver in your zone threatens to step out of bounds, observe them – don't rely on the Back Judge to cover the end line alone.
3. Indicate a score by blowing your whistle and giving the touchdown signal [S5] only when you clearly see the ball break the plane of the goal line in player possession or if you see a pass completed in the end zone.
4. If a pile-up forms at the goal line, come into the field of play until you can see the ball. If you are the nearest official, you may need to dig for it. Check with other officials that they did not see the ball carrier down (or fumble the ball) before [the ball²](#) reached the goal line.
5. If you have goal line responsibility and it is necessary to move out of the players' way as they come towards you, move wider without leaving the goal line.
6. Do not give a score signal if you have thrown a penalty flag for a foul by the scoring team. Do not blow your whistle or give any signal if you are not sure about the outcome of the play.
7. If you have goal line responsibility, straddle the goal line – don't run after the player into the end zone unless there is a threat of trouble by or against them, but do turn to keep your eyes on them to observe late hits or unsportsmanlike conduct.
8. If another official has sideline responsibility, do not signal touchdown until you have confirmed with them that the ball carrier was not out of bounds.
9. Maintain the touchdown signal until you know the Referee has seen it, but keep your eyes on the players – don't look to the Referee until all action has ceased. Don't run and signal at the same time. You should not echo the signals of other officials unless the Referee cannot see their signal.
10. It is especially important on goal line plays that all covering officials indicate the same point of forward progress. Communicate if in doubt. Signal only if sure.

14.5.d – Advanced techniques

1. Communicate (preferably verbally) as to who has the responsibility for the goal line and end line before each down. In noisy situations, point at the line you have responsibility for.
2. If you have sideline/end line responsibility, on a running play towards the goal line pylon, assist the wing official by watching the ball carrier to see if they step out of bounds. This allows the wing official to give priority to the goal line.

14.6 - Returns

14.6.a – Priorities

1. Observing the ball carrier and action around them while you are the nearest official.
2. Marking the forward progress or out of bounds spot if the ball becomes dead on your side of the field. This responsibility extends up to Team A's 2-yard line. If the ball goes to the other side of the field, backing up your colleague on the other side of the field by either estimating the dead-ball spot or mirroring their spot.
3. Observing any fumble where you are the nearest official or have the best view, and marking the spot with a bean bag.
4. Observing blocks by players in your area of responsibility ahead of and around the ball carrier, particularly:
 - (a) illegal block in the back and holding fouls at the point of attack
 - (b) illegal block below the waist fouls anywhere
 - (c) safety-related fouls such as face mask, tripping, chop blocks or illegal blind-side blocks
 - (d) assisting the runner
 - (e) contacting an opponent with the crown of the helmet or targeting a defenseless opponent above the shoulders
 - (f) late hits by any player after the ball is dead
5. Observing any [legal⁰](#) hand-off or pass where you are the nearest official or have the best view, and marking the spot with a bean bag.

6. Observing any *illegal* forward pass or forward handing, especially if you have a view that is level or nearly level with the ball carrier.

14.6.b – Response to what happens (movement and signals)

1. Keep out of the players' way.
2. Move towards Team A's goal line following the play.
3. Observe the ball carrier while they remain on your side of the field or towards the middle. Try and keep them boxed in between you and the wing official. Be prepared to close in when the ball becomes dead and mark the forward progress spot. The wing official may be in a better position than you to cover the ball carrier, in which case they will normally be the one to declare the ball dead and mark the forward progress.
4. If the ball carrier is on the opposite side of the field, observe players in the middle of the field as well as on your side.
5. If you are watching a block develop, stay with it before switching to the ball carrier or another block. Even if you expect another official to take responsibility for it, stay with the block until you are confident it is legal.
6. If the ball becomes dead in your area of responsibility, blow your whistle, give the timeout signal [S3], and then signal first down [S8] to show which team is in possession. Hold the signal until you know the Referee has seen it.

14.7 - Punts

14.7.a – Priorities

Before and during the kick, applying the same priorities as on basic scrimmage plays (above), plus:

1. [IN xx2 FORMATION (CREW OF 6D)] Marking the end of the kick (if inbounds) with a bean bag.
2. Marking the dead-ball spot for any kick that goes out of bounds in your area.
3. Ruling whether players touched the ball or not.
4. Observing any fair catch signals by players in your area.
5. Observing kick-catch interference against a player in position to catch the kick, if the kick comes down in your area.
6. If the kick does not come down in your area, observing players who have *not* committed kick-catch interference because they were blocked by an opponent into the returner.
7. Marking all spots of illegal touching with a bean bag.
8. Ruling whether a momentum exception applies or not near the goal line.
9. Observing fouls by all players generally in your area, but particularly:
 - (a) illegal blocks below the waist, especially by players on your side of the field
 - (b) during the kick, illegal block in the back and holding fouls against Team A players trying to get down the field
 - (c) a Team A player returning inbounds after voluntarily going out of bounds during the down ([dropping](#)² your bean bag or hat to mark their exit, and your flag if they return)
 - (d) kick catch interference when the kicked ball will land in your area
 - (e) illegal blocks made by players who have signalled for a fair catch
 - (f) contacting an opponent with the crown of the helmet or targeting a defenseless opponent above the shoulders
 - (g) safety-related fouls such as face mask, tripping, chop blocks or illegal blind-side blocks
 - (h) unnecessary roughness fouls away from the ball
 - (i) late hits by any player after the ball is dead
10. Noting the numbers of players in eligible receiver positions on your side of the formation, and observing whether anyone else is the first to touch the ball or is ineligibly downfield if the play develops into a pass play.
11. Responding to bad snaps or blocked kicks by adopting run, pass or return priorities, as appropriate.

During [the](#) punt return, applying the same priorities as on returns (above).

14.7.b – Initial positioning

1. [IN xx3 FORMATION (CREW OF 7/8)]
 - (a) Be on or outside the sideline slightly deeper than the deepest returner. Be level with the [Back Judge](#), [unless the Back Judge is clearly in the wrong position, in which case attempt to correct them.](#) [USING O2O/CREW RADIO] is one way to do this. [◊]
 - (b) Ensure you can see any shallow returner(s) in your half of the field, or, if none, the deepest potential blockers.
2. [IN xx2 FORMATION (CREW OF 6D)]
 - (a) Be behind and to the side of the deepest returner. Behind so that you can look through them and see the ball kicked. To the side so that you are out of their way, but still close enough to observe whether they touch the ball or not, or whether any opponent interferes with their opportunity to catch the kick. About 5 yards behind is the appropriate depth. [FIELD JUDGE] Remain between the returner and your sideline. About 10 yards away from the returner is an appropriate lateral position, unless you are at or near the goal line, in which case be at your goal line pylon. [SIDE JUDGE] Remain on the sideline.

- (b) If there is more than one returner deep, take position between your sideline and the nearer of them, keeping well outside the nearest returner until it is clear that returner will not handle the ball.
3. [SNAP FROM INSIDE TEAM B'S 40-YARD LINE OR THE PUNT RETURNER IS INSIDE TEAM B'S 10-YARD LINE] Be in an initial position out of bounds near the goal line pylon. Stand where you can see in a straight line over the pylon towards where the kick will come from. Be prepared to rule on whether the kick goes out of bounds in the field of play or in the end zone. Once it is obvious that your pylon will not be threatened by the loose ball, move to be on the goal line extended.
 4. Be prepared to adjust your position according to the strength and direction of the wind, and the ability of the kicker.
 5. Have a bean bag readily available and a second one to hand.
 6. [IN xx3 FORMATION (CREW OF 7/8)] The Back Judge will have responsibility for the end of the kick, unless it ends very close to a sideline *or the Back Judge is well out of position,*[§] in which case it is the responsibility of the nearest sideline official.
 7. [IN xx2 FORMATION (CREW OF 6D)] The Field Judge is responsible for the deepest returner and kicks that end near them, and the Side Judge is responsible for all shallower returners except those near the Line Judge. If there are two deep returners, the Field Judge and Side Judge each take responsibility for their nearest returner and kicks that end near them. If there are more than two, the Field Judge will normally take responsibility for the two nearest them. The Field Judge and Side Judge always work from the outside in.

14.7.c – Response to what happens (movement and signals)

1. When the ball is kicked, observe its initial trajectory, but do not watch the flight of the ball. Observe players in your area of responsibility (defined by the diagrams in section 26.4) – their eyes will tell you where the ball is going. However, if the returner moves as a decoy, do not follow them - observe the area where the ball will come down.
2. When it appears obvious that the kicked ball will *not* land in your area:
 - (a) Hold your original lateral position. This will assist in signalling to other officials that you are covering action in front of the returner.
 - (b) Maintain a position where you can cover action in front of and around the returner. If you are the nearest official *other than* the official covering the punt returner, move to where you can observe players blocking in the vicinity of any returner who is in position to catch the kick. In particular, observe those *blocked by an opponent* into interfering and therefore immune to penalty (Rule 6-4-1-d).
 - (c) Move so that you can observe action around the ball carrier if the play is away from you. Be prepared to take over responsibility for the ball carrier if they cut back to your side. [IN xx2 FORMATION (CREW OF 6D)] Move into a Back Judge role in the centre of the field if the play remains on the opposite side, but be prepared to get back to your sideline ahead of the play if its direction changes back towards you.
 - (d) If a player in your area signals for a fair catch, watch that they do not block before they touch the ball (Rule 6-5-4).
 - (e) Do not hesitate to call a foul if you clearly see one occur in the area where you are the cleanup official even though you may be a considerable distance away from the action. Communicate with your colleagues to find out their view of the action.
3. When it appears obvious that the kicked ball *will* land in your area:
 - (a) Unless you are responsible for the deepest returner, give a punch signal [Sup28] to your colleagues to indicate that you are assuming responsibility for the kick and the nearest returner.
 - (b) Move into position wide of and behind the returner aiming to be at a 45 degree angle to rule on the validity of the catch.
 - (c) If the kick is first muffed (but not possessed) by a member of Team B beyond the neutral zone, you may give the ball touched signal [S11] to signify that Team A is now eligible to touch it.
 - (d) Use bean bags to mark any spots of illegal touching and/or the spot where the kick ends. Only one official, the Coverer in each case, should mark each spot and give each signal. If you have more spots than bean bags, prioritise the spot most advantageous to Team B.
 - (e) If the ball becomes dead because it is caught or recovered by Team B after a fair catch signal, or caught or recovered by Team A after being touched by Team B, blow your whistle and give the timeout signal [S3]. Give the first down signal [S8] in the appropriate direction.
 - (f) If the ball is not caught and goes deeper than the returner, follow the ball and be prepared to rule on its status. Stay far enough away from it that there is no danger of it touching you.
 - (g) If the ball approaches the goal line, be *in the best position*^o on the goal line to rule on whether it enters the end zone. *This will normally be outside the goal line pylon (usually 2 yards or more) for your safety.*[§] Other officials will cover the players.
 - (h) If the ball does enter the end zone (untouched by Team B beyond the neutral zone) and touches the ground or is downed by Team B in the end zone, blow your whistle and signal touchback [S7], repeating the signal until you know the Referee has seen it.
 - (i) If the kick is recovered by Team A without it being touched by Team B, blow your whistle, signal timeout [S3] and give the illegal touching signal [S16] and the first down signal [S8]. Momentary touching of the ball by a player of the kicking team should not be interpreted as control of the ball.

- (j) If the kick goes out of bounds in your area, blow your whistle and signal timeout [S3] immediately.
 - (i) If the ball touches anything (e.g. the ground or a player) in bounds and then goes out of bounds, move directly to the spot where you judge the ball crossed the sideline.
 - (ii) If the ball goes out of bounds in flight, the Referee or Centre Judge *may* be able to assist by directing you to the spot. Look back to the Referee or Centre Judge to see if either can help. If either can, signal [Sup16] and respond to the instructions they give you using signals [Sup17, Sup18 & Sup19] to direct you to the crossing point. If they can't, move directly to the spot where your best judgement tells you the ball crossed the sideline.
 - (iii) Hold the spot, but do not place a ball at it unless a spare is at hand. Other officials will retrieve/relay a ball to the Spotter.
- (k) If the ball rolls to a stop in your area, ensure no player is attempting to recover it before blowing your whistle and signalling timeout [S3].

During the punt return, respond as in the section "Returns" (above).

14.7.d – Advanced techniques

1. If the ball is snapped on or inside Team B's 40-yard line, there will be [IN xx2 FORMATION (CREW OF 6D)] two or [IN xx3 FORMATION (CREW OF 7/8)] three officials on the goal line. The officials boxing in the ball should together rule on whether it crosses the goal line (communicating well to avoid conflicting calls), while [IN xx3 FORMATION (CREW OF 7/8)] the other official rules on the actions of the players around it (see also 5.4.10).[◇] Stay on the goal line until you are certain the ball will not cross it.
2. If Team B does not line up in a punt return formation (i.e. no deep returner), adopt your normal scrimmage down position. This is justified because if Team A does kick the ball deep, there will be no players there for you to have to cover. If the ball is kicked deep, adjust your position accordingly, but only the nearest official to the ball should need to observe it. The other officials should observe the players.
3. Be alert for cases where the kick is blocked or where there is a bad snap. This also applies if Team A switches to a run or pass formation.
 - (a) If the play turns into a run or pass, respond as you would do normally for that type of play.
 - (b) Cover the goal line and end line as appropriate (see the section in this chapter on "Goal line plays").^λ
 - (c) Be aware of the jersey numbers of the eligible receivers.

14.8 - Field goal & try attempts

14.8.a – Priorities

Before and during the kick, applying the same priorities as on basic scrimmage plays (above), plus:

1. [IN xx2 FORMATION (CREW OF 6D) OR FIELD JUDGE ON A CREW OF 7/8] Ruling the success or failure of the field goal attempt. [IN xx2 FORMATION (CREW OF 6D)] The Field Judge and Side Judge share this responsibility. [IN xx3 FORMATION (CREW OF 7/8)] The Field Judge shares this responsibility with the Back Judge.
2. [IN xx3 FORMATION (CREW OF 7/8)] [SIDE JUDGE]
 - (a) Observing fouls by all players generally in your area, but particularly:
 - (i) illegal block in the back and holding fouls by linemen and backs protecting the kicker, especially the end and/or wing back on your side
 - (ii) defensive players illegally attempting to block the kick (defensive restrictions), e.g. by using leverage or leaping[§]
 - (iii) illegal blocks below the waist
 - (iv) any action against the snapper that might be roughing
 - (v) contacting an opponent with the crown of the helmet or targeting a defenseless opponent above the shoulders
 - (vi) safety-related fouls such as face mask, tripping, chop blocks or illegal blind-side blocks
 - (vii) players meeting opponents with a knee
 - (viii) late hits by any player after the ball is dead
 - (ix) illegal formation
 - (b) After the ball is kicked, continuing to observe players until they are totally separated. Never turning around to see whether the kick is successful or not, never echoing the success/failure signals made by the official(s) ruling on the kick, never writing down the score, never getting a new ball, never doing anything other than observing the players until there is no possible threat of trouble.
3. Observing illegal touching or batting of the ball.
4. Observing players' celebrations after a score.
5. Noting the numbers of players in eligible receiver positions on your side of the formation and observing whether anyone else is the first to touch the ball or is ineligibly downfield if the play develops into a pass play.
6. Responding to bad snaps or blocked kicks by adopting run, pass or return priorities, as appropriate.

During a field goal return, applying the same priorities as on returns (above).

14.8.b – Initial positioning

1. [IN xx2 FORMATION (CREW OF 6D) OR THE FIELD JUDGE ON A CREW OF 7/8] Take position about one yard behind the goal post on your side of the field. You are responsible for ruling whether the ball passes inside your upright. [IN xx2 FORMATION (CREW OF 6D)] [FIELD JUDGE] In addition you are responsible for ruling whether the ball passes above the crossbar.
2. [IN xx3 FORMATION (CREW OF 7/8)] [SIDE JUDGE] Be in a double umpire position. Watch defensive players who may violate rules related to gaining leverage to block a kick.

14.8.c – Response to what happens (movement and signals)

1. [IN xx2 FORMATION (CREW OF 6D) OR FIELD JUDGE ON A CREW OF 7/8]
 - (a) Observe the ball from kick to when it becomes obvious whether the attempt will be successful or not.
 - (b) If you consider the kick to be successful, communicate ("good", nod) with your colleague behind the posts and together come out between the uprights (approximately one yard into the end zone) giving the score signal [S5] as you come to a stop.
 - (c) If you consider the kick to have failed, give the no score signal [S10]. If the kick is wide to your side, you may also give the kick wide signal [Sup15]. Do *not* signal a touchback **unless Team B has touched the ball beyond the neutral zone.**[Ⓞ]
 - (d) Hold either signal for at least five seconds and until you know the Referee has seen it.
 - (e) [IN xx2 FORMATION (CREW OF 6D)] [FIELD JUDGE] Blow your whistle when the result of the kick is obvious. There is no need to wait until the ball touches the ground (or something else) provided it is clear what the result of the kick is/will be.
 - (f) If the kick is short or blocked and the ball is possessed by Team B, move into position to officiate the kick play as a punt **return.**[Ⓛ]
2. [IN xx3 FORMATION (CREW OF 7/8)] [SIDE JUDGE] Maintain a position where you can watch the initial charge, check blocking by the offense and action by defensive players, particularly the end player and wing back on your side of the offensive formation.

14.8.d – Advanced techniques

1. **Note the numbers of the (normally) two eligible receivers on your side of the offensive formation so that, if a pass develops, you can rule on ineligible touching a pass or being illegally downfield.**[§]
2. Be alert for cases where the kick is blocked or where there is a bad snap. This also applies if Team A switches to a run or pass formation.
 - (a) [IN xx2 FORMATION (CREW OF 6D) OR FIELD JUDGE ON A CREW OF 7/8] Stay in position as long as there is the possibility of a drop kick attempt.
 - (b)[Ⓛ] If a run or pass develops, read the play and respond as appropriate.
 - (i) If the play develops to one side of the field and you are the nearer of the two officials behind the goal, move towards the sideline.
 - (ii) On an obvious running play or pass play short of the goal line, you may need to come infield and cover the goal line. **This is normally the official behind the post furthest from the play, in order to help box in the goal line with any trailing wing official.**[§]
 - (iii) Stay on the end line if a pass into the end zone is possible.
 - (c) [IN xx3 FORMATION (CREW OF 7/8)] [SIDE JUDGE] Stay in your position and observe the actions against Team A players on your side of the formation.
 - (d) If the ball is recovered and advanced by Team B, follow the return up the field.
3. If Team A switches to a run or pass formation, move to assume your normal scrimmage position.
 - (a) [SIDE JUDGE] [IN xx3 FORMATION (CREW OF 7/8)] Stay in the double umpire position unless you have time to get to the goal line pylon before the ball is snapped and without turning your back to the players. [IN xx2 FORMATION (CREW OF 6D)] Do as the Field Judge does (below).
 - (b) [FIELD JUDGE] You need to get to your goal line pylon as quickly as possible (diagonally across the end zone if safe to do so). During the play, be aware of the wing official's position and if they are going to get to the goal line first, you should divert to the end line pylon. At all times cover play in the end zone.

14.9 - After each down**14.9.a – Priorities**

1. Observing dead-ball action by players of both teams.
2. Encouraging the players to unpile safely, and either return the ball to an official or leave it near the dead-ball spot, as appropriate.
3. Checking whether the line to gain has been reached or is close, and signalling appropriately.
4. Checking whether any penalty flags have been thrown, and, if so:
 - (a) Giving the timeout signal [S3].
 - (b) Reporting any fouls you have called to the Referee and Umpire.
 - (c) Covering penalty flags (and bean bags, if appropriate) thrown by colleagues.
 - (d) Ensuring that all penalties are enforced correctly.

5. Checking for injured players or other occurrences that may delay play.
6. [ON-FIELD TIMEKEEPER] Stopping and starting the clock when necessary.
7. [ON-FIELD PLAY CLOCK OPERATOR] Starting the play clock when necessary, giving a 10-second warning, and throwing a delay of game flag if the clock reaches 0 before the ball is put in play.
8. Allowing legitimate requests for timeouts. Checking that a request coming from the coaching box or team area was made by the Head Coach.
9. Echoing all timeout signals [S3] of your colleagues.
10. Knowing whether the play ended inbounds, and informing the Referee that the clock (if stopped) should start on the ready by giving them the clock running signal [Sup12].
11. Assisting in relaying the dead ball or a new ball to the succeeding spot.
12. If you are not covering the play, assisting in maintaining order on the field by moving towards where the play ended.

14.9.b – Response to what happens (movement and signals)

1. If you are the Coverer, check whether the line to gain has been reached.
 - (a) If it has, give the timeout signal [S3]. After all action has ceased, signal first down [S8 or Sup35]. Hold the signal until you know the Referee is aware of it.
 - (b) If you are not sure whether the line to gain has been reached or not, signal timeout [S3] and yell "close". Encourage the Referee to come and look for themselves.
 - (c) Only place a ball on the ground at the *actual* dead-ball spot – never at a spot level with it.
 - (d) If the play ended inbounds, inform the Referee that the clock should start on the ready by giving them the clock running signal [Sup12].
2. If you are the Coverer, [give only one signal that the ball is dead](#). See paragraph 6.5.14.[‡]
3. If a penalty flag has been thrown follow the procedure in Chapter 19. [If an inadvertent whistle has been blown, follow the procedure in Section 6.15.](#)[§] If a team or injury timeout has been called, follow the procedure in Chapter 17. If a period has ended, follow the procedure in Chapter 20.
4. [ON-FIELD PLAY CLOCK OPERATOR] If a 40-second clock should start by rule:
 - (a) If there is a stadium play clock, check that it started shortly after the end of the play.
 - (b) If there is no stadium play clock, start a 40-second count shortly after the end of the play.

Relaying the ball:

5. If you have the ball, but another official has the dead-ball spot and it is close to the line to gain, hand the ball to that official and allow them to spot it at the precise location (yard line *and* lateral position) where the ball became dead.
6. Unless you are the Coverer, assist in relaying a ball to the official who will place it at the succeeding spot (MOFO 6.7).
7. If a ball has been placed at the dead-ball spot in a side zone, and another ball is being relayed in to the succeeding spot, do not move the ball at the dead-ball spot until the replacement ball has been positioned at the correct location [at the inbounds spot](#).[‡]

Getting ready for the next down:

8. Maintain order at the sideline and in the team areas.
9. [ON-FIELD TIMEKEEPER] Remind the Referee of the clock status and, if stopped, remind them whether it should start on the snap or on the ready.
 - (a) If the clock has stopped for a foul, injury or helmet coming off and there is less than **two minutes**[®] in the half, make sure the Referee knows that there is a possible 10-second runoff.
 - (b) Be prepared for a ruling by the Referee on when the clock should start in unfair clock tactics situations.
 - (c) Start the clock when the Referee gives (or should give) the start the clock signal [S2], unless you are sure that by rule the clock should start on the snap, or the ball is obviously not ready for play (e.g. because ball, chains, down box or officials are not in position). Do *not* echo the Referee's signal, but use the clock-on-ready signal [Sup12] if necessary to confirm that the clock has started.
 - (d) If the game clock should start on the snap, start it when you see the ball legally snapped. There is no need to give a signal to confirm this.
 - (e) [Your primary responsibility is to get the time accurate by rule, not to follow erroneous Referee's signals about time \(Exception: unfair clock tactics situations\), but work together to get things right \(MOFO 6.12.4\).](#)[§]
10. If there are stadium game clocks, check to see that they have stopped and started correctly.
11. If substitutions are made from your side of the field, check that Team A players fulfil the nine-yard mark requirements (Rule 7-1-3-b).
12. Move into position for the next down. If the ball is ready for play (or will be imminently), backpedal to keep your eyes on the ball. Do not take your eyes off it for long in case the play starts while you are not looking.
13. [ON-FIELD PLAY CLOCK OPERATOR]
 - (a) If the ball is not ready for play 20 seconds into the play count (Rule 3-2-4-b-3), signal to the Referee [Sup29] that the play clock should be reset to 25 seconds.
 - (b) If there is no visible play clock:[@]
 - (i) [\[USING O2O/CREW RADIO\] when approximately 12 seconds remain on the play clock, alert colleagues with "10 seconds";](#)

- (ii) when approximately 10 seconds remain on the play clock, raise a hand high in the air [signal S7] until either the ball is snapped or a delay of game flag is thrown. Do not give any additional signal (e.g. a countdown).
- (c) When the play clock reaches 0, look at the snapper. If the ball is already moving, there is no foul. Otherwise, blow your whistle and throw your flag for delay of game.

14.9.c – Advanced techniques

1. The priority at the end of a play is to get into position ready for the next one. Only if a serious incident occurs (such as a foul or misconduct, an injury, or a breakage of the chain) should your routine be interrupted.
2. If Team A makes substitutions **while the snapper is at, near or moving towards** their position at the line of scrimmage:
 - (a) Any official should be prepared to step in and shut down a play that violates the substitution rule.
 - (b) Give the matching substitutes signal [Sup36] to the Referee and shout "subs on".
 - (c) **Drop the signal when** the Referee has taken control of the process.
3. **Procedures intended to allow the defense to match up must not be used for a substitution for a last-second field goal. In that situation, Team A is making a normal and expected personnel change and Team B should be prepared to respond appropriately. In no case should an official be standing over the ball to prevent the snap as the clock runs out.** §
4. If you want to speak to a player on the field (e.g. to warn them that they are close to fouling), it often saves time to relay the message via the Referee or Centre Judge (for a Team A player) or the Umpire or Back Judge (for a Team B player). Don't delay the game unnecessarily by entering either team's huddle, unless a timeout is still in progress. Never attempt to speak to a player during a hurry-up or no-huddle offense.
5. Maintain your concentration, and think about the next play.

15. BACK JUDGE (CREW OF 7/8)

15.1 - Free kicks

15.1.a – Priorities

Prior to the kick:

1. Being aware of whether the Referee has instructed the crew to switch to onside-kick positions, and moving position (if appropriate) if they have.
2. Counting Team A players and signalling the count [one of Sup3, Sup4 or Sup24] to colleagues. Noting count signals from colleagues. Recounting if your count differs from that of colleagues.
3. Reminding the players to count their number if the team you are responsible for counting does not have precisely **the correct number of²** players on the field.
4. Checking readiness for play:
 - (a) Checking side areas to ensure that all non-players are out of the restricted areas, that non-participants are off the field of play, **that the safety zone is clear,[®]** and that all team personnel are within the team area.
 - (b) Ensuring that the chain crew (and the alternate down box and line-to-gain marker operators, where provided) have moved themselves and their equipment well out of the way and that the equipment has been placed on the ground outside the team areas and **outside the safety zone[®]** at the receiving team's end of the field. Checking that the ball persons are in position.
 - (c) Ensuring that all Team A players **have been within the nine-yard marks after the ready for play and prior to the kick,²** (Rule 6-1-2-c-5) and that nobody other than the kicker is more than five yards behind the ball.
 - (d) Facing the field of play to signal that you are ready. Turning away, **or obviously leaving your position,[°]** if something on your sideline becomes no longer clear or you can see that a colleague is clearly not ready. Sounding your whistle, if your area becomes dangerously unclear after the ready for play.
5. Being alert always for short kicks.

During the kick play:

6. Observing whether a free kick goes out of bounds nearest to you without being touched by the receiving team. Ruling whether a Team B player near the sideline touches the ball while out of bounds.
7. Watching players for a fair catch signal, and being prepared to rule on any interference with the opportunity to catch the kick.
8. If the kick is short:
 - (a) Knowing where and by whom the ball was first touched.
 - (b) Observing illegal blocks by Team A (Rule 6-1-12).
 - (c) Marking any spot of illegal touching with a bean bag.
 - (d) Marking the dead-ball spot if you are the nearest official and there is little or no return run.
9. Giving the start the clock signal [S2] only if the ball is first legally touched in the field of play **and you are the nearest official or you have the best view of it.**
10. Observing fouls/violations by all players generally in your area, but particularly:
 - (a) illegal touching of a short kick
 - (b) infractions of your restraining line
 - (c) kicking team players (other than the kicker) more than 5 yards behind their restraining line after the ready for play
 - (d) illegal blocks in the back and holding fouls at the point of attack
 - (e) illegal blocks below the waist
 - (f) contacting an opponent with the crown of the helmet or targeting a defenseless opponent above the shoulders
 - (g) safety-related fouls such as face mask, tripping, chop blocks, illegal wedges or illegal blind-side blocks
 - (h) late hits by any player after the ball is dead
 - (i) any player of the kicking team who enters the field of play after the kick or who voluntarily goes out of bounds during the kick and returns inbounds
 - (j) **illegal forward handing or illegal forward passes**

15.1.b – Initial positioning

Normal kicks:

1. Be in position F (see 26.1) outside the press box sideline on Team A's restraining line.

Onside-kicks:

2. Remain in the normal position.

Free kicks after a penalty or safety:

3. When a free kick is taken following a penalty or a safety, the same relative positions should be taken, moving up or down the field as appropriate.

15.1.c – Response to what happens (movement and signals)**Prior to the kick:**

1. If anything happens that should prevent the kick taking place (e.g. a non-player enters or approaches the field of play), toot your whistle, give the timeout signal [S3] and deal with the problem.

During any kick play:

2. If the clock should start when the ball is first legally touched in the field of play, give the start the clock signal [S2] if you are the nearest official or the one with the best view.

During a kick play that goes deep:

3. After the ball is kicked, observe the players in your area of responsibility (see 26.1). After checking its initial trajectory, do not watch the flight of the ball.
4. Angle slowly infield as you move down the field. Observe action ahead of the ball carrier. Keep all players in front of you and maintain a safe cushion between you and the return, while not being too far away to get your flag to the spot of a foul you observe. On a long run, stay ahead of the players and get to the goal line ahead of the ball carrier. **You have shared responsibility for the goal line.** § You also have² responsibility for the end line should that be threatened (e.g. after a fumble near Team A's goal line). When you are sharing responsibility for a line (or pair of lines) with other officials, adjust so that you get a complementary view of the play.

During a kick play where the kick is short:

5. Maintain a position where you can see the ball and the blocks by Team A players.
6. Particularly **observe**² the blocks made by Team A players before they are eligible to touch the ball (Rule 6-1-12).

15.1.d – Advanced techniques

1. Pay particular attention to the blocks made by the middle player(s) from Team B's front line.
2. If an expected inside kick is instead kicked deep, move into the field of play. You, the Umpire and the other official on Team A's restraining line each take responsibility for one third of the middle of the field (Figures 26.1.I and 26.1.J). Leave sideline responsibility in your area to the Field Judge.
3. **After the ball is dead and all action is ceased, if you are the nearest official to the previous spot make sure that any kicking tee has been removed from the field.** ◊

15.2 - Basic scrimmage plays**15.2.a – Priorities**

1. Knowing the down and distance, and signalling the down to your colleagues. Noting the down signals given by colleagues. Checking that the down box displays the correct number. Not allowing play to start if there is a dispute about the down number.
2. Counting Team B players and signalling the count [one of Sup3, Sup4 or Sup24] to your colleagues. Noting count signals from colleagues. Recounting if your count differs from that of colleagues.
3. Identifying your key player(s) (see section 16.6). If the formation is new or unusual, verbally or visually confirming this with the other officials.
4. Noting eligible receivers and those players who would normally be eligible by position but who are ineligible by number. In addition, noting players (usually tight ends) who would normally be eligible by number but who are not eligible because a player is lined up outside them on the line of scrimmage.
5. Being aware of where the line to gain is in relation to the line of scrimmage so that you don't have to look at the chain to know if the dead-ball spot is close to the line to gain.
6. Observing substitution infractions by both teams. For example:
 - (a) replaced players not leaving the huddle within 3 seconds of an incoming substitute entering it
 - (b) substitutes coming on to the field, communicating, and then leaving the field
7. **Alerting colleagues if Team A makes a substitution while the snapper is at, near or moving towards their position at the line of scrimmage.** §

15.2.b – Initial positioning

1. Normally be 25 yards or so from the line of scrimmage, inside the hash marks.
2. Be deep and clear of players, but able to see all receivers, especially your key player.
3. Normally, you will be deeper than the deepest back, but be sure to keep out of their way.
4. **Normally, you will be deeper than the Field Judge and Side Judge.** §
5. Favour the strong side of the formation, or, if it is balanced, the side of the player who is your key.

15.2.c – Response to what happens (movement and signals)

1. Always be in position to cover play from the inside looking out.
2. Be aware of a backfield player (as long as they are your key player) in motion at the snap. Adjust your position if necessary to ensure that you always have them in sight. They become your responsibility after the snap (unless they were the widest player in the formation at the snap) if they cross the neutral zone on a pass play or if they block outside the tackle on a running play.
3. If there is a pre-snap foul, maintain a position where you can see all players (especially on the fringes) who may commit a late hit.
4. Read the play to judge whether it will be a deep one that requires you to move backwards towards the goal line or end line. If the play is not a deep one, you do not need to move any deeper to cover it.

15.2.d – Advanced techniques**Reasons for varying (or not) your initial position:**

1. On "take a knee" plays, come up into a double umpire position. Tell other officials that you are doing this. Use your presence to deter unsportsmanlike acts.
2. On obvious "hail mary" plays, start deeper than normal and make sure you can get to Team B's goal line or end line before any Team A player.

Signalling the player count:

3. The latest time to make the player count signal is when the offensive team breaks its huddle (but it can and should be done earlier if possible).
4. Normally the player count signal is shared between the Field Judge, Side Judge and Back Judge.

15.3 - Running plays**15.3.a – Priorities**

1. Observing action ahead of the ball carrier.
2. Observing any fumble where you are the nearest official or have the best view, and marking the spot with a bean bag if possible.
3. Ruling whether a touchdown is scored or not on a breakaway run.
4. Observing fouls by all players generally in your area, but particularly:
 - (a) illegal block in the back and holding fouls at the point of attack, especially those made by your key player or any wide receiver, tight end, lead back or pulling lineman
 - (b) illegal block below the waist fouls by your key player and other players in your area
 - (c) contacting an opponent with the crown of the helmet or targeting a defenseless opponent above the shoulders
 - (d) safety-related fouls such as face mask, tripping, chop blocks or illegal blind-side blocks
 - (e) late hits by any player after the ball is dead
5. Getting to the goal line ahead of any ball carrier in order to be able to rule on a touchdown.

15.3.b – Response to what happens (movement and signals)

1. Move to observe actions by players behind the Umpire and ahead of the ball carrier. **Don't move deeper until you read that a long run is developing.** Don't move forwards until you know where the ball is likely to become dead.
2. On line plunges up the middle, do not move too fast. Let the play come to you.
3. When a running play develops toward a sideline, move slightly towards that sideline, keeping the ball carrier between you, the sideline official and the sideline. Stay ahead of the play and keep out of the way of the safeties.
4. Observe action ahead of the ball carrier and point of attack. There is no need to observe receivers ahead of the point of attack who are not blocking.
5. On long runs, try to stay ahead of the ball carrier and keep them boxed in between you and the deep wing official. Keep out of the players' way.
6. If you are the nearest official when the ball becomes dead, blow your whistle and move to deal with the pile. Only if the wing officials are delayed (or obviously missed a knee down or similar event) do you need to mark the dead-ball spot.
7. Be on Team B's goal line before a touchdown is scored.
8. If you are not the nearest official to the dead-ball spot, nevertheless move towards it and observe the continuing action after the ball becomes dead. On plays when the ball carrier goes near the sideline or out of bounds, cover the area around them for extra-curricular activity. This may bring you to a position near or outside the nine-yard marks.
9. Maintain a position where you can observe player activity in fringe areas, particularly on wide-open plays.

15.3.c – Advanced techniques

1. Don't blow your whistle when the ball carrier's back is toward you or you are obscured by other players or officials² – they may have fumbled the ball without you seeing it. See leather! Be certain that the ball is dead.
2. If a pile-up of players forms, give the timeout signal [S3], converge on the pile, determine who has possession (MOFO 6.10) and encourage players to unpile safely.
3. If you're not the nearest official to the dead-ball spot, observe for late hits and other illegal acts. It is particularly your responsibility to observe action close to the wing officials as they are concentrating on the forward progress spot.
4. Because the Back Judge is not very often directly involved in running plays, it is important to maintain concentration throughout the game. You may be the only official to observe some action away from the ball or behind another official's back.

15.4 - Pass plays**15.4.a – Priorities**

1. Ruling whether the pass is complete or incomplete. While primarily this will be for passes to the middle of the field, in practice you may need to rule on any pass where the receiver is facing or at right angles to you, regardless of their position. Similarly, if the receiver has their back to you, you may need to defer to another official with a better view than you.
2. Ruling on touchdowns on passes into the end zone.
3. Observing the initial contact by and against your key player(s).
4. Observing fouls by all players generally in your area, but particularly:
 - (a) defensive and offensive pass interference
 - (b) defensive holding and illegal use of hands against eligible receivers
 - (c) illegal block below the waist fouls by any motion man and all players in the middle of the field
 - (d) illegal touching of a forward pass by a player who went out of bounds voluntarily (this may require consultation with a sideline colleague)
 - (e) contacting an opponent with the crown of the helmet or targeting a defenseless opponent above the shoulders
 - (f) safety-related fouls such as face mask, tripping, chop blocks or illegal blind-side blocks
 - (g) late hits by any player after the ball is dead
5. Advising the Referee if the pass was thrown into an area not occupied by an eligible receiver.
6. Watching for players who go out of bounds beyond the end line.

Once the pass is complete, apply the same priorities as on a running play (above).

15.4.b – Response to what happens (movement and signals)

1. Your progression on a pass play is: (phase A) your key player; (phase B) your zone; (phase C) the destination of the pass. See also Chapter 16.
2. **If you read a short pass, hold your position until the pass is caught. Then or if you read a deep pass, backpedal to keep all receivers in front of you.** Don't move forwards until you know where the ball is likely to become dead. Ensure that you can see blocking and contact by and against any eligible receivers in the middle of the field. Never get beaten deep.
3. On long pass receptions, be prepared to rule on the goal line and the end line.
4. Only watch your key player during the initial action after the snap when there is a threat of illegal contact between receiver and defender. Switch to zone coverage as soon as that threat no longer exists.
5. If receivers run routes into the end zone, move into position on the end line.
6. If a potential Team A receiver voluntarily goes out of bounds in your area, drop your bean bag or hat to indicate this, and observe them to see whether they touch a forward pass while still ineligible.
7. Once you are aware that the pass has been thrown, move into position to best be able to rule on whether the pass is complete or incomplete, and whether there is interference. While the ball is in flight, watch opposing players who are contesting for the ball, not the ball itself. Be alert to both offensive and defensive pass interference.
8. If the player who attempts to catch the ball has their back to you, before making the call, look for help from any official in a better position than you.
9. If you are not the nearest official, don't just watch the receiver, but particularly watch for defenders slightly away from the ball who come in and target the receiver with the crown of their helmet or above the shoulders. This is often missed by the nearest official.
10. **If the pass is a screen pass (i.e. does not cross the neutral zone), focus on the blocks in advance of the receiver, observing holding and illegal use of hands fouls in that area.** §
11. If the pass is overthrown, bounces off a player or is otherwise uncatchable, continue to watch the player(s) for personal fouls (hitting a defenseless receiver). Do not ball-watch.
12. Blow your whistle if you see the ball become dead in your area.
13. If you rule that the pass is incomplete, give the incomplete pass signal [S10].

14. When contact that would have been pass interference occurs on a pass that is uncatchable, give the uncatchable pass signal [S17].
15. After an incompletion, ensure that the thrown ball is removed from the field. Repeat the incomplete pass signal [S10] to the Referee (and Umpire, if necessary) in case they did not see the original signal.
16. If there is a run after the catch, respond as you would on a running play (above).
17. On plays when the receiver goes near the sideline or out of bounds, cover the area around them for extra-curricular activity. This may bring you to a position near or outside the nine-yard marks.
18. Maintain a position where you can see player activity in fringe areas, particularly on wide-open plays.

15.4.c – Advanced techniques

1. When an airborne player attempts to catch a pass near the sideline or end line, watch their feet first to see whether they come down in bounds. If they do, then look to their hands to see whether they have control of the ball. If you look at their hands first, you may miss the instant when their foot touches the ground (MOFO 5.4.8). Establish eye contact with any colleague at the end of the play before giving any signal.
2. If the pass is incomplete in your area:
 - (a) If there is no eligible receiver in the area, move quickly towards the Referee to inform them of this. If the ball crossed the neutral zone, give signal [Sup42] by pointing to the ground beyond the neutral zone. If the ball did not cross the neutral zone, move towards the Referee while pointing to the ground behind the neutral zone.
 - (b) If there *is* a receiver in the area, and you believe the Referee may not be aware of that fact, move towards the Referee while pointing towards the eligible receiver. Calling out "Number 34 was in the area of the pass" (for example) is also permissible.
 - (c) [USING O2O/CREW RADIO] Transmitting this information is also an option.

15.5 - Goal line plays

15.5.a – Priorities

Same priorities as on other scrimmage plays, plus:

1. Ruling whether a touchdown is scored or not. This includes all passes into the end zone, and running plays if the ball is snapped outside Team B's 25-yard² line.
2. Observing players' celebrations after a score.

15.5.b – Initial positioning

1. [SNAP FROM BETWEEN TEAM B'S 30 AND 25-YARD LINES] Take up initial position on the goal line.
2. [SNAP FROM BETWEEN TEAM B'S 25 AND 15-YARD LINES] Take up initial position several yards deep in the end zone. Move to cover whichever of the goal line or end line is more important as the play develops.
3. [SNAP FROM ON OR INSIDE TEAM B'S 15-YARD LINE] Take up initial position on the end line.
4. If the ball is snapped from inside Team B's 7-yard line, the other deep officials will also be in position on/near the end line. Your responsibility for the end line is shared with the official on the side to which the play is made.

15.5.c – Response to what happens (movement and signals)

1. Move to observe all players in your area of responsibility. If a pass is thrown into the end zone, move to the best position to rule on the end of the pass. If the pass is thrown into a deep corner of the end zone, this will normally be somewhere on the end line between the hash marks and the nine-yard marks.
2. Indicate a score by blowing your whistle and giving the touchdown signal [S5] only if you see a pass completed in the end zone.
3. If a pile-up forms at the goal line, come into the field of play until you can see the ball. If you are the nearest official, you may need to dig for it. Check with other officials that they did not see the ball carrier down (or fumble the ball) before [the ball²](#) reached the goal line.
4. Do not give a score signal if you have thrown a penalty flag for a foul by the scoring team. Do not blow your whistle or give any signal if you are not sure about the outcome of the play.
5. Maintain the touchdown signal until you know the Referee has seen it, but keep your eyes on the players – don't look to the Referee until all action has ceased. Don't run and signal at the same time. You should not echo the signals of other officials unless the Referee cannot see their signal.
6. If the end of the play is not in your area of responsibility, move into position to assist in the clean-up of continuing action around or away from the ball.

15.6 - Returns

15.6.a – Priorities

1. Observing the ball carrier and action around them while you are the nearest official.
2. Observing any fumble where you are the nearest official or have the best view, and marking the spot with a bean bag.

3. Observing blocks by players in your area of responsibility ahead of and around the ball carrier, particularly:
 - (a) illegal block in the back and holding fouls at the point of attack
 - (b) illegal block below the waist fouls anywhere
 - (c) safety-related fouls such as face mask, tripping, chop blocks or illegal blind-side blocks
 - (d) assisting the runner
 - (e) contacting an opponent with the crown of the helmet or targeting a defenseless opponent above the shoulders
 - (f) late hits by any player after the ball is dead
4. Observing any *legal*^o hand-off or pass where you are the nearest official or have the best view, and marking the spot with a bean bag.
5. Observing any *illegal* forward pass or forward handing, especially if you have a view that is level or nearly level with the ball carrier.

15.6.b – Response to what happens (movement and signals)

1. Keep out of the players' way.
2. Move towards Team A's goal line following the play.
3. If the change of possession occurs in your area of responsibility, observe the ball carrier as you would on a running play. Otherwise, observe action around and away from the play.
4. If you are watching a block develop, stay with it before switching to the ball carrier or another block. Even if you expect another official to take responsibility for it, stay with the block until you are confident it is legal.
5. If the ball becomes dead in your area of responsibility, blow your whistle, give the timeout signal [S3], and then signal first down [S8] to show which team is in possession. Hold the signal until you know the Referee has seen it.
6. If you are not the nearest official to the dead-ball spot, nevertheless move towards it and observe the continuing action after the ball becomes dead. On plays when the ball carrier goes near the sideline or out of bounds, move laterally to cover the area around them for extra-curricular activity. This may bring you to a position near or outside the nine-yard marks.

15.7 - Punts

15.7.a – Priorities

Before and during the kick, applying the same priorities as on basic scrimmage plays (above), plus:

1. Marking the end of the kick (if inbounds) with a bean bag.
2. Ruling whether players touched the ball or not.
3. Observing any fair catch signals by players in your area.
4. Observing kick-catch interference against a player in position to catch the kick, if the kick comes down in your area.
5. If the kick does not come down in your area, observing players who have *not* committed kick-catch interference because they were blocked by an opponent into the returner.
6. Marking all spots of illegal touching with a bean bag.
7. Ruling whether a momentum exception applies or not near the goal line.
8. Observing fouls by all players generally in your area, but particularly:
 - (a) illegal blocks below the waist, especially by players in the middle of the field
 - (b) during the kick, illegal block in the back and holding fouls against Team A players trying to get down the field
 - (c) kick catch interference when the kicked ball will land in your area
 - (d) illegal blocks made by players who have signalled for a fair catch
 - (e) contacting an opponent with the crown of the helmet or targeting a defenseless opponent above the shoulders
 - (f) safety-related fouls such as face mask, tripping, chop blocks or illegal blind-side blocks
 - (g) unnecessary roughness fouls away from the ball
 - (h) late hits by any player after the ball is dead
9. Responding to bad snaps or blocked kicks by adopting run, pass or return priorities, as appropriate.

During *the* punt return, applying the same priorities as on returns (above).

15.7.b – Initial positioning

1. Be behind and to the side of the deepest returner. Behind so that you can look through them and see the ball kicked. To the side so that you are out of their way, but still close enough to observe whether they touch the ball or not, or whether any opponent interferes with their opportunity to catch the kick. About 5-8 yards behind and 5-8 yards to the side is an appropriate distance, allowing for the speed of the returner and weather conditions. If there is more than one returner deep, take position where you can see all of them.
2. [SNAP FROM INSIDE TEAM B'S 40-YARD LINE OR THE PUNT RETURNER IS INSIDE TEAM B'S 10-YARD LINE] Be in an initial position on the goal line in the middle of the field.

3. Be prepared to adjust your position according to the strength and direction of the wind, and the ability of the kicker. Move closer to the sideline where the wind is likely to carry the kicked ball.
4. Have a bean bag readily available and a second one to hand.
5. You will have responsibility for the end of the kick, unless it ends very close to a sideline **or you are well out of position,**[§] in which case it is the responsibility of the nearest sideline official.

15.7.c – Response to what happens (movement and signals)

1. When the ball is kicked, observe its initial trajectory, but do not watch the flight of the ball. Observe players in your area of responsibility (defined by the diagrams in section 26.4) – their eyes will tell you where the ball is going. However, if the returner moves as a decoy, do not follow them - observe the area where the ball will come down.
2. When it appears obvious that the kicked ball will *not* land in your area:
 - (a) If the kick is short and to either sideline, the sideline official will assume responsibility for the ball. They will give the punch signal [Sup28] to indicate this.
 - (b) Maintain a position where you can cover action in front of and around the returner. If you are the nearest official *other than* the official covering the punt returner, move to where you can observe players blocking in the vicinity of any returner who is in position to catch the kick. In particular, observe those *blocked by an opponent* into interfering and therefore immune to penalty (Rule 6-4-1-d).
 - (c) If a player in your area signals for a fair catch, watch that they do not block before they touch the ball (Rule 6-5-4).
 - (d) Do not hesitate to call a foul if you clearly see one occur in the area where you are the cleanup official even though you may be a considerable distance away from the action. Communicate with your colleagues to find out their view of the action.
3. When it appears obvious that the kicked ball *will* land in your area:
 - (a) Move into position wide of (at least 10 yards unless they are near the sideline) and behind the returner aiming to be at a 45 degree angle to rule on the validity of the catch.
 - (b) If the kick is first muffed (but not possessed) by a member of Team B beyond the neutral zone, you may give the ball touched signal [S11] to signify that Team A is now eligible to touch it.
 - (c) Use bean bags to mark any spots of illegal touching and/or the spot where the kick ends. Only one official, the Coverer in each case, should mark each spot and give each signal. If you have more spots than bean bags, prioritise the spot most advantageous to Team B.
 - (d) If the ball becomes dead because it is caught or recovered by Team B after a fair catch signal, or caught or recovered by Team A after being touched by Team B, blow your whistle and give the timeout signal [S3]. Give the first down signal [S8] in the appropriate direction.
 - (e) If the ball is not caught and goes deeper than the returner, follow the ball and be prepared to rule on its status. Stay far enough away from it that there is no danger of it touching you.
 - (f) If the ball approaches the goal line, be **in the best position**[◊] on the goal line to rule on whether it enters the end zone. Other officials will cover the players.
 - (g) If the ball does enter the end zone (untouched by Team B beyond the neutral zone) and touches the ground or is downed by Team B in the end zone, blow your whistle and signal touchback [S7], repeating the signal until you know the Referee has seen it.
 - (h) If the kick is recovered by Team A without it being touched by Team B, blow your whistle, signal timeout [S3] and give the illegal touching signal [S16] and the first down signal [S8]. Momentary touching of the ball by a player of the kicking team should not be interpreted as control of the ball.
 - (i) If the ball rolls to a stop in your area, ensure no player is attempting to recover it before blowing your whistle and signalling timeout [S3].

During the punt return, respond as in the section "Returns" (above).

15.7.d – Advanced techniques

1. If the ball is snapped on or inside Team B's 40-yard line, there will be three officials on the goal line. You and the nearest deep wing official should box in the ball and together rule on whether it crosses the goal line (communicating well to avoid conflicting calls), while the other official rules on the actions of the players around it (see also 5.4.10).[◊] Stay on the goal line until you are certain the ball will not cross it.
2. If Team B does not line up in a punt return formation (i.e. no deep returner), adopt your normal scrimmage down position. This is justified because if Team A does kick the ball deep, there will be no players there for you to have to cover. If the ball is kicked deep, adjust your position accordingly, but only the nearest official to the ball should need to observe it. The other officials should observe the players.
3. Be alert for cases where the kick is blocked or where there is a bad snap. This also applies if Team A switches to a run or pass formation.
 - (a) If the play turns into a run or pass, respond as you would do normally for that type of play.
 - (b) Cover the goal line and end line as appropriate (see the section in this chapter on "Goal line plays").^λ
 - (c) Be aware of the jersey numbers of the eligible receivers.

15.8 - Field goal & try attempts

15.8.a – Priorities

Before and during the kick, applying the same priorities as on basic scrimmage plays (above), plus:

1. Ruling the success or failure of the field goal attempt. You share this responsibility with the Field Judge.
2. Observing illegal touching or batting of the ball.
3. Observing players' celebrations after a score.
4. Noting the numbers of players in eligible receiver positions and observing whether anyone else is the first to touch the ball or is ineligible downfield if the play develops into a pass play.
5. Responding to bad snaps or blocked kicks by adopting run, pass or return priorities, as appropriate.

During a field goal return, applying the same priorities as on returns (above).

15.8.b – Initial positioning

1. Take position about one yard behind the goal post furthest from the press box. You are responsible for ruling whether the ball passes inside your upright **and above the crossbar.** ^λ **The Field Judge has responsibility for the other upright.** [§]

15.8.c – Response to what happens (movement and signals)

1. Observe the ball from kick to when it becomes obvious whether the attempt will be successful or not.
2. If you consider the kick to be successful, communicate ("good", nod) with your colleague behind the posts and together come out between the uprights (approximately one yard into the end zone) giving the score signal [S5] as you come to a stop.
3. If you consider the kick to have failed, give the no score signal [S10]. If the kick is wide to your side, you may also give the kick wide signal [Sup15]. Do *not* signal a touchback **unless Team B has touched the ball beyond the neutral zone.** [◊]
4. Hold either signal for at least five seconds and until you know the Referee has seen it.
5. Blow your whistle when the result of the kick is obvious. There is no need to wait until the ball touches the ground (or something else) provided it is clear what the result of the kick is/will be.
6. If the kick is short or blocked and the ball is possessed by Team B, move into position to officiate the kick play as a punt **return.** ^λ

15.8.d – Advanced techniques

1. **Note the numbers of the (normally) two eligible receivers on your side of the offensive formation so that, if a pass develops, you can rule on ineligibles touching a pass or being illegally downfield.** [§]
2. Be alert for cases where the kick is blocked or where there is a bad snap. This also applies if Team A switches to a run or pass formation.
 - (a) Stay in position as long as there is the possibility of a drop kick attempt.
 - (b) ^λ If a run or pass develops, read the play and respond as appropriate.
 - (i) If the play develops to one side of the field and you are the nearer of the two officials behind the goal, move towards the sideline.
 - (ii) On an obvious running play or pass play short of the goal line, you may need to come infield and cover the goal line. **This is normally the official behind the post furthest from the play, in order to help box in the goal line with any trailing wing official.** [§]
 - (iii) Stay on the end line if a pass into the end zone is possible.
 - (c) If the ball is recovered and advanced by Team B, follow the return up the field.
3. If Team A switches to a run or pass formation, move to assume your normal scrimmage position. At all times cover play in the end zone.

15.9 - After each down

15.9.a – Priorities

1. Observing dead-ball action by players of both teams.
2. Encouraging the players to unpile safely, and either return the ball to an official or leave it near the dead-ball spot, as appropriate.
3. Checking whether the line to gain has been reached or is close, and signalling appropriately.
4. Checking whether any penalty flags have been thrown, and, if so:
 - (a) Giving the timeout signal [S3].
 - (b) Reporting any fouls you have called to the Referee and Umpire.
 - (c) Covering penalty flags (and bean bags, if appropriate) thrown by colleagues.
 - (d) Ensuring that all penalties are enforced correctly.
5. Checking for injured players or other occurrences that may delay play.
6. [ON-FIELD PLAY CLOCK OPERATOR] Starting the play clock when necessary, giving a 10-second warning, and throwing a delay of game flag if the clock reaches 0 before the ball is put in play.

7. Allowing legitimate requests for timeouts. Checking that a request coming from the coaching box or team area was made by the Head Coach.
8. Echoing all timeout signals [S3] of your colleagues.
9. Assisting in relaying the dead ball or a new ball to the succeeding spot.
10. If you are not covering the play, assisting in maintaining order on the field by moving towards where the play ended.

15.9.b – Response to what happens (movement and signals)

1. In the rare event that you are the Coverer, check whether the line to gain has been reached.
 - (a) If it has, give the timeout signal [S3]. After all action has ceased, signal first down [S8 or Sup35]. Hold the signal until you know the Referee is aware of it.
 - (b) If you are not sure whether the line to gain has been reached or not, signal timeout [S3] and yell "close". Encourage the Referee to come and look for themselves.
 - (c) Only place a ball on the ground at the *actual* dead-ball spot – never at a spot level with it.
 - (d) If the play ended inbounds, inform the Referee that the clock should start on the ready by giving them the clock running signal [Sup12].
2. If you are the Coverer, **give only one signal that the ball is dead**. See paragraph 6.5.14. ²
3. If a penalty flag has been thrown follow the procedure in Chapter 19. **If an inadvertent whistle has been blown, follow the procedure in Section 6.15.** [§] If a team or injury timeout has been called, follow the procedure in Chapter 17. If a period has ended, follow the procedure in Chapter 20.
4. [ON-FIELD PLAY CLOCK OPERATOR] If a 40-second clock should start by rule:
 - (a) If there is a stadium play clock, check that it started shortly after the end of the play.
 - (b) If there is no stadium play clock, start a 40-second count shortly after the end of the play.

Relaying the ball:

5. If you have the ball, but another official has the dead-ball spot and it is close to the line to gain, hand the ball to that official and allow them to spot it at the precise location (yard line *and* lateral position) where the ball became dead.
6. Unless you are the Coverer, assist in relaying a ball to the official who will place it at the succeeding spot (MOFO 6.7).
7. If a ball has been placed at the dead-ball spot in a side zone, and another ball is being relayed in to the succeeding spot, do not move the ball at the dead-ball spot until the replacement ball has been positioned at the correct location **at the inbounds spot**. ²

Getting ready for the next down:

8. Move into position for the next down. If the ball is ready for play (or will be imminently), backpedal to keep your eyes on the ball. Do not take your eyes off it for long in case the play starts while you are not looking.
9. If the ball is not ready for play 20 seconds into the play count (Rule 3-2-4-b-3), signal to the Referee [Sup29] that the play clock should be reset to 25 seconds.
10. If there is no visible play clock: [@]
 - (a) **[USING O2O/CREW RADIO] when approximately 12 seconds remain on the play clock, alert colleagues with "10 seconds";**
 - (b) when approximately 10 seconds remain on the play clock, raise a hand high in the air [signal S7] until either the ball is snapped or a delay of game flag is thrown. Do not give any additional signal (e.g. a countdown).
11. When the play clock reaches 0, look at the snapper. If the ball is already moving, there is no foul. Otherwise, blow your whistle and throw your flag for delay of game.

15.9.c – Advanced techniques

1. The priority at the end of a play is to get into position ready for the next one. Only if a serious incident occurs (such as a foul or misconduct, an injury, or a breakage of the chain) should your routine be interrupted.
2. **Double check that the Spotter has put the ball at the correct lateral position.** [§]
3. If Team A makes substitutions **while the snapper is at, near or moving towards** their position at the line of scrimmage:
 - (a) Any official should be prepared to step in and shut down a play that violates the substitution rule.
 - (b) Give the matching substitutes signal [Sup36] to the Referee and shout "subs on".
 - (c) **Drop the signal when** the Referee has taken control of the process.
4. **Procedures intended to allow the defense to match up must not be used for a substitution for a last-second field goal. In that situation, Team A is making a normal and expected personnel change and Team B should be prepared to respond appropriately. In no case should an official be standing over the ball to prevent the snap as the clock runs out.** [§]
5. If you want to speak to a player on the field (e.g. to warn them that they are close to fouling), it often saves time to relay the message via the Referee or Centre Judge (for a Team A player). Don't delay the game unnecessarily by entering either team's huddle, unless a timeout is still in progress. Never attempt to speak to a player during a hurry-up or no-huddle offense.
6. Maintain your concentration, and think about the next play.

16. PASS PLAY COVERAGE

16.1 - Terminology

1. On each side of the offensive formation, players in receiver positions outside the tackles are identified by their position. The widest receiver (the one closest to the [sideline](#)⁴) is #1, the next widest is #2, and so on, for however many receivers are on that side of the formation. When receivers are *stacked* (lined up one behind another) or *bunched* (lined up close together) on one side of the formation, the one closest to the line of scrimmage is #1 and the one behind them is #2, etc.
2. A forward pass play consists of three *phases*:
 - (a) Phase A is immediately after the snap when receivers are making their initial movement.
 - (b) Phase B is while players are running their pass routes or otherwise trying to establish their position on the field to receive a pass.
 - (c) Phase C is while the ball is in the air, [and until it is complete or incomplete](#).[◇]
3. In determining keys, the following definitions are needed:
 - (a) Strength of the formation – determined by the number of receivers on a particular side of the offensive formation. The strong side is the side with the most receivers. It has nothing to do with the number of linemen on each side of the snapper but rather the number of receivers positioned outside the tackles. [IN xx1/xx3 FORMATION (CREW OF 5/6C/7/8)] If there is no strong side (balanced formation), the Line Judge's side is deemed to be the strong side.
 - (b) Tight end / split end – the end player on the line of scrimmage. A *tight end* is usually lined up no more than 4 yards from the nearest offensive lineman. If they are lined up wider, then they are a *split end*.
 - (c) Slot back / flanker back – a back lined up outside the nearest interior lineman or tight end. A *slot back* is usually lined up no more than 4 yards from the nearest offensive lineman. If they are lined up wider then they are a *flanker back*.
 - (d) Back in the backfield – a player in the backfield between the tackles at the snap.
 - (e) Press coverage – when a defender lines up in a position where they are close enough that they can touch the receiver as the receiver leaves the line of scrimmage.
 - (f) Trips – three receivers on one side of the offensive formation outside the tackles.
 - (g) Quads – four receivers on one side of the offensive formation outside the tackles.
4. It does not matter in determining keys whether a player is:
 - (a) on or off the line of scrimmage; or
 - (b) wearing a number between 50-79 or not.
5. If the formation is illegal (e.g. too many players in the backfield, more than one player in motion at the snap), the crew should failsafe to keys based on the position of players at the snap.
6. If the formation is new or unusual then verbally or visually confirm keys with other officials.

16.2 - General principles for pass play coverage

1. During Phase A, be in man coverage, watching receivers who are covered by defenders in press coverage.
 - (a) During this phase, there is likely to be physical contact between the defender and the receiver, and the responsible official must be able to rule on whether that is legal or not.
 - (b) The most common fouls in this situation are defensive holding and offensive pass interference.
 - (c) Receivers who are *not* covered do not normally need to be observed, since the likelihood of a foul being committed by or against them is low. However, that may change due to the movement of the players.
 - (d) If your key receiver(s) is not threatened by a defender, switch immediately to Phase B.
2. During Phase B, be in zone coverage, observing receivers and defenders in your zone.
 - (a) Only observe receivers who are close to defenders, since it is those players who are threatened by being fouled. Receivers and defenders who are not close to opponents should not be observed because there is little risk of a foul. The exception to this is any receiver who approaches a boundary line. [You](#)⁴ need to know if they go out of bounds voluntarily and thereby lose their eligibility to touch a pass.
 - (b) If there are no players in your zone who are close to an opponent, expand your zone until it includes close opponents who may not be being observed by another official.
 - (c) In the early stages of a play, as receivers cross the line of scrimmage, the zones for which the deep officials are responsible will be very close to the line of scrimmage. As receivers move downfield, those deep zones will expand and shallow zones will form behind them.
 - (d) If there is more than one receiver in your zone who is close to an opponent, normally observe the one nearer you, since it is more likely that another official will be able to observe the other(s). This calls for good teamwork between the Back Judge, the wing officials and the deep wing officials.
 - (e) The most common fouls during Phase B are defensive holding, offensive pass interference and illegal use of hands (Rule 9-3-4-e).
 - (f) In addition, look out for receivers going out of bounds (voluntarily or forced) at the sideline or end line.

3. During Phase C, be in destination coverage, observing receivers and defenders in the vicinity of where the pass will arrive. When the destination of the pass is obviously out of bounds, observe players nearest to that point.
 - (a) Only observe receivers who are close to defenders, since it is those players who are threatened by being fouled. Receivers and defenders who are not close to opponents should not be observed because there is little risk of a foul.
 - (b) The most common fouls in this situation are defensive pass interference and offensive pass interference.
 - (c) During this phase you also have a responsibility to observe fouls away from the destination zone such as unnecessary roughness and unsportsmanlike conduct.
4. The following sections cover the responsibilities of the pass-covering officials on each size of crew. The responsibilities listed here do not normally apply to the Referee, Umpire or Centre Judge, except that, in Phase C, the Umpire should also always observe action in the vicinity of where the pass will arrive.^o

16.3 - Crew of 4

1. During Phase A, the wing officials key all eligible receivers (#1-#4) on their side of the field. Where there is more than one eligible receiver, the primary key is any receiver in press coverage.
2. During Phase B, each wing official is responsible for the zone covering their half of the field.
3. During Phase C, each official is responsible for observing action in the vicinity of where the pass will arrive.

16.4 - Crew of 5/6C

1. During Phase A:
 - (a) The Back Judge always keys on the inside eligible receiver(s) outside the tackles (normally #2, but #3 in trips or #4 in quads) on the strong side of the formation. This will normally be the tight end or slot back.
 - (b) The wing officials always key on the widest player of the offensive formation on their side of the field (#1). This will normally be either a split end or a flanker back unless the Back Judge is keying on them.
 - (c) If the formation is balanced and there is only one eligible receiver to each side, the Back Judge has no key. If there are two receivers to each side, the Back Judge keys on the inside player (#2) on the Line Judge's side, and the Down Judge keys on the two on their side (#1 and #2), giving priority to one who is in press coverage.
 - (d) If there are three eligible receivers on the strong side, who keys on the #2 receiver will depend on whether #2 is closer to #1 or #3. If #2 is closer to #1, the wing official will key on #1 and #2. If #2 is closer to #3, the Back Judge will key on #3 and #2.
 - (e) If there are quads, who keys on the #2 and #3 receivers will depend on where they are relative to #1 and #4. If either or both is close to #1, the wing official will key on #1 and #2 (and #3 if all are close). If either or both is close to #4, the Back Judge will key on #4 and #3 (and #2 if all are close).
 - (f) A player who goes in motion will be the responsibility of the Back Judge unless they are the widest player at the snap.
2. During Phase B:
 - (a) The Back Judge will have the zone containing the deepest receiver, particularly if the receiver is in or moving towards the middle of the field.
 - (b) The wing officials will have the zone containing shallow receivers in their half of the field, plus any deep receiver who is not covered by the Back Judge, and any receiver who is moving towards, or threatens to go out of bounds on, their side.
3. During Phase C, each official is responsible for observing action in the vicinity of where the pass will arrive.

16.5 - Crew of 6D

1. During Phase A:
 - (a) The deep wing officials always key on the widest player of the offensive formation on their side of the field (#1).
 - (b) The wing officials always key on the most inside receiver outside the tackles (#2-#4) (often the tight end or slot back) on their side of the field. If there is only one receiver, the wing official has no key.
 - (c) If there are trips, who keys on the #2 receiver will depend on whether #2 is closer to #1 or #3. If #2 is closer to #1, the deep wing official will key on #1 and #2. If #2 is closer to #3, the wing official will key on #3 and #2.
 - (d) If there are quads, who keys on the #2 and #3 receivers will depend on where they are relative to #1 and #4. If either or both is close to #1, they are keyed by the deep wing official. If either or both is close to #4, they are keyed by the wing official.
 - (e) If there is motion, keys are determined by the position of the motion man at the snap (not by their direction). If they are the widest player (#1) then they will be the responsibility of the deep wing official on that side, otherwise they are keyed by the wing official.
2. During Phase B:
 - (a) Each deep wing official is responsible for the zone containing the deepest receiver in their half of the field.
 - (b) Each wing official is responsible for the zone covering all shallow receivers in their half of the field.
3. During Phase C, each official is responsible for observing action in the vicinity of where the pass will arrive.

16.6 - Crew of 7/8

1. During Phase A:
 - (a) The Side Judge and Field Judge always key on the widest player of the offensive formation on their side of the field (#1). This includes the motion man if their motion makes them the widest player at the snap.
 - (b) If there is a back in motion, the Back Judge keys on them unless they are the widest player on their side of the formation at the snap.
 - (c) If there are 2 receivers to the strong side, the Back Judge always keys on #2. If the formation is balanced, the Back Judge keys on #2 on the Line Judge's side and the **Down Judge** keys on #2 on their side.
 - (d) A wing official has no key if the deep wing officials and Back Judge are keying on all players on their side of the formation.
 - (e) If there are trips, the Back Judge keys on #3 and the wing official keys on #2.
 - (f) If there are quads, the Back Judge normally keys on #4 and #3 and the wing official keys on #2. However, if #3 is separate from #4 and nearer #2 the wing official keys on #3 as well as #2.
2. During Phase B:
 - (a) Each deep wing official is responsible for the zone containing the deepest receiver in their third of the field.
 - (b) The Back Judge is responsible for the zone containing the deepest receiver in the middle of the field.
 - (c) Each wing official is responsible for the zone containing shallow receivers in their half of the field.
3. During Phase C, each official is responsible for observing action in the vicinity of where the pass will arrive.

16.7 - Summary

The table shows which official keys on which receiver according to the receiver's position on their side of the formation.

Formation		Crew of 5/6C		Crew of 6D		Crew of 7/8		
		Wing	BJ	Wing	Deep	Wing	Deep	BJ
Balanced	1	1	-	-	1	-	1	-
	1_2	12D	2L	2	1	-	1	2
Normal	1	1	-	-	1	-	1	-
	1_2	1	2	2	1	-	1	2
Trips	12_3	12	3	3	12	2	1	3
	1_23	1	23	23	1	2	1	3
Quads	1_234	1	234	234	1	2	1	34
	12_34	12	34	34	12	2	1	34
	123_4	123	4	4	123	23	1	4
	1_23_4	12	34	34	12	23	1	4
Motion	M_2	M			M		M	
	1_M		M	M				M

16.8 - Crew of 5 examples

This section also covers crews of 6C with the addition of the Centre Judge in the offensive backfield opposite the Referee.

Figure A: Pro set

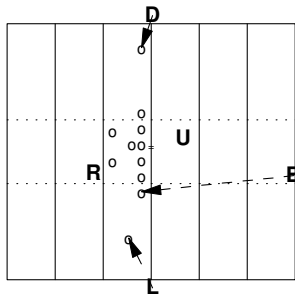

L's side is the strong side.

Figure B: Slot formation

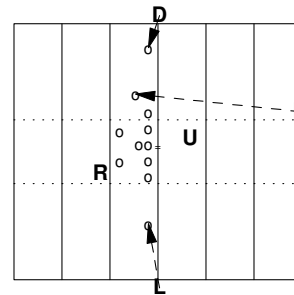

D's side is the strong side. B keys on the slot back on that side. D keys on the split end. L keys on the split end on the other side.

Figure C: Wishbone formation

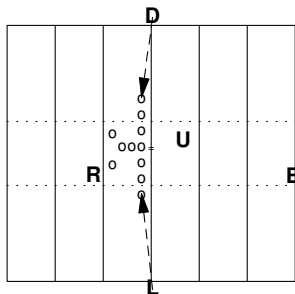

Balanced formation with one receiver each side. B keys on first back out of the backfield.

Figure D: Single-wing formation

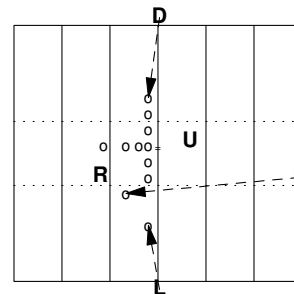

L's side is the strong side. B keys on the slot back. L keys on the split end. D keys on the tight end to their side.

Figure E: Spread formation

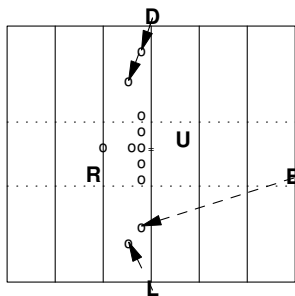

Formation is balanced with two receivers each side; strength declared to L's side. B keys on second player in on that side. L keys on the flanker on that side. D must key on both receivers on their side.

Figure F: Double-wing formation

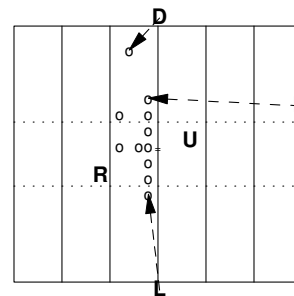

D's side is the strong side. B keys on the tight end on that side. L keys on the other tight end. D keys on the flanker back on their side.

Figure G: Triple receivers on one side (1)

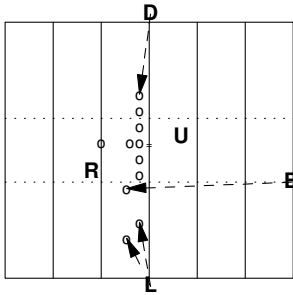

L's side is the strong side. B keys on the slot back. L keys both the split end and the flanker back.⁴ D keys on the tight end who is positioned on the weak side.

Figure I: Motion which changes strength

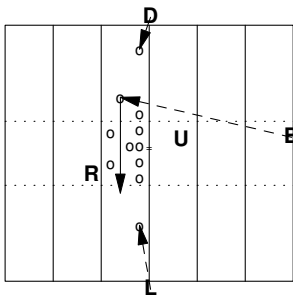

Strength is initially to D's side. D keys on split end on their side. L keys on split end on other side. B keys on the slot back and stays with them as they change sides.

Figure H: Triple receivers on one side (2)

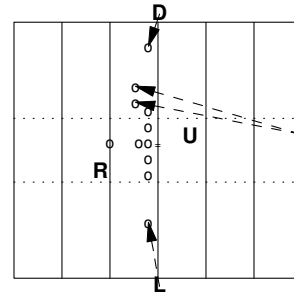

D's side is the strong side. B keys on both slot backs. D keys split end on that side. L keys on split end on other side.

Figure J: Motion which does not change strength

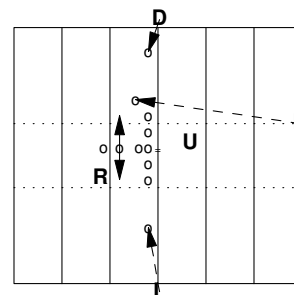

Strength is initially to D's side. D keys on split end on D's side. L keys on split end on weak side. B keys on slot back, and also the motion man if they are near the slot back at the snap. If the motion man goes to the L's side, the strength changes, B has only the motion man, and D needs to key on both players on their side.

16.9 - Crew of 6D examples

Figure A: Pro set

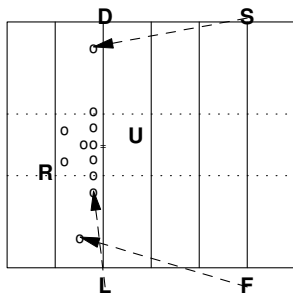

L's side is the strong side. F keys on the flanker. S keys on the split end. L keys on the tight end.

Figure B: Spread receivers

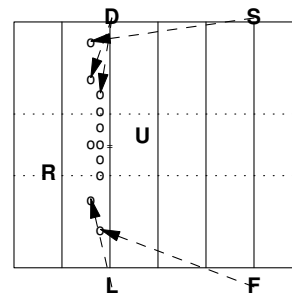

D's side is the strong side. F keys on the split end^λ on the weak side. L keys on the second receiver on that side. S keys on the flanker back. D keys on the end on their side and the remaining receiver.

Figure C: Double tight end and balanced backfield

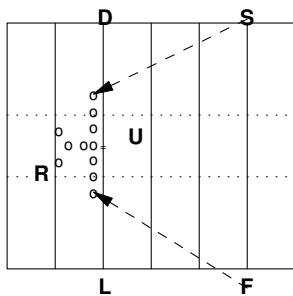

Balanced formation. S & F key on the tight ends.

Figure D: Motion

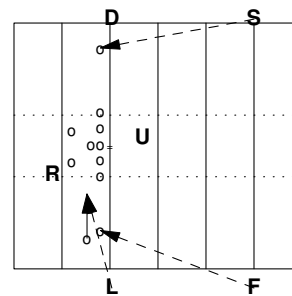

When the motion man ceases to be the widest player in the formation, they become L's responsibility and F^λ keys on the split end.

16.10 - Crew of 7 examples

This section also covers crews of 8 with the addition of the Centre Judge in the offensive backfield opposite the Referee.

Figure A: Pro set

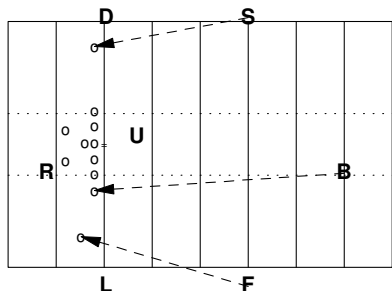

L's side is the strong side. F keys on the flanker. S keys on the split end. B keys on the tight end.

Figure B: Spread receivers

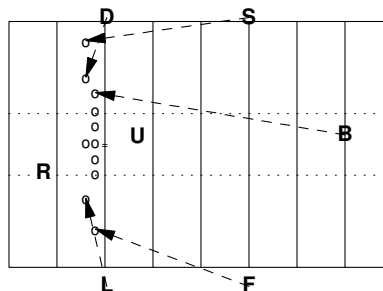

D's side is the strong side. F keys on the split end^λ on the weak side. L keys on the second receiver on that side. S keys on the flanker back. D keys on the second receiver on their side. B keys on the most inside receiver on the strong side.

Figure C: Double tight end and balanced backfield

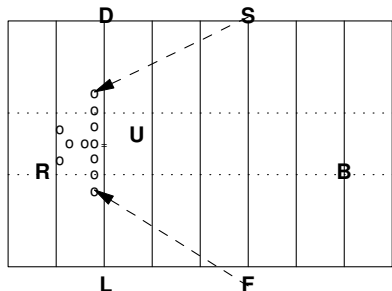

Balanced formation with one receiver outside the tackles on each side. S & F key on the tight ends.

Figure D: Motion

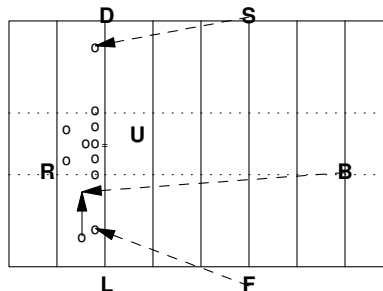

When the flanker goes in motion B^λ and F exchange keys.

17. TIMEOUTS

17.1 - Charged timeouts

1. If, when the ball is dead, a player, substitute inside the nine-yard marks or Head Coach requests a timeout (and their team has at least one timeout left), immediately blow your whistle and signal timeout [S3]. Notify the Referee of the team and number of the requesting player, or that the timeout was requested by the Head Coach.
2. If a request for a timeout is made when the ball is live, wait until the end of the play and then confirm with the requester whether the timeout is still required. If it is, then follow the procedure above.
3. [REFEREE] Signal a requested charged timeout by facing the press box, giving the timeout signal [S3] followed by a "chucking signal" with the arms shoulder high towards the requesting team's goal line. [USING PUBLIC RADIO] Announce the timeout, identifying clearly (normally by team name) which team it is to be charged to and how many they have used. There is no need to sound your whistle.
4. [REFEREE] If the timeout is the third and final one charged to that team, in addition to the chucking signal, give three pulls on an imaginary steam whistle (without blowing your whistle). [USING PUBLIC RADIO] Announce that it is the team's final timeout. You must personally ensure that the Head Coach and the on-field captain of the team are aware that all their timeouts have been used.
5. [ON-FIELD TIMEKEEPER] Ensure that all your colleagues are informed of the exact time remaining in the quarter and that they pass the information on to the Head Coach and on-field captain of each team, as appropriate.
6. All officials must record all timeouts, including the quarter and time remaining on the clock.
7. [REFEREE] [USING PUBLIC RADIO] If a stadium clock is not visible, you should announce the time remaining. This is particularly important in the last few minutes of a half.
8. [UMPIRE] Time the timeout interval (MOFO 6.12). If a team huddles near the sideline or leaves the field of play, ask [the nearest sideline](#)^o official to alert [the team that the timeout is nearly over](#)² when approximately 15 seconds of the timeout remain. Otherwise, alert the Referee when approximately 5 seconds of the timeout remain.
9. During the timeout:
 - (a) [UMPIRE OR CENTRE JUDGE]² Remain with the ball at the succeeding spot [until the Referee informs you to leave it prior to them declaring the ball ready for play.](#)[†]
 - (b) [DOWN JUDGE, LINE JUDGE, FIELD JUDGE AND SIDE JUDGE]
 - (i) [If you are the nearest official,](#)^o inform the Head Coach of the team on your side of the field of the number of timeouts remaining for each team and the time remaining if a stadium clock is not visible.
 - (ii) Observe the team from your side of the field, including checking the number of players in the huddle. If the team huddles near the sideline or leaves the field of play, stand near enough to them so that you can inform [the team that the timeout is nearly over](#)² when approximately 15 seconds of the timeout remain, [and encourage players to move back onto the field.](#)[§]
 - (c) [IN xx1/xx3 FORMATION (CREW OF 5/6C/7/8)] [BACK JUDGE]
[IN xx0/xx2 FORMATION (CREW OF 4/6D)] [UMPIRE] Inform the defensive captain of the time and the number of timeouts their team has remaining.
 - (d) [REFEREE] Inform the offensive captain of the time and the number of timeouts their team has remaining.
 - (e) If a coach enters the field to speak to their players, this should not normally be a problem provided:
 - they do not go on to the field more than 9 yards;
 - they do not go beyond the 20-yard line [boundaries of the team area;](#)^o
 - their players gather around them.

[If this is not the case, gently move the coach and/or players into that zone.](#)[§]
10. [REFEREE, CENTRE JUDGE OR UMPIRE] [If the team that called the timeout wishes to resume play before the end of the timeout, the nearest official should check with the on-field captain of the opposing team to ascertain whether their team is ready. This is not necessary if the opposing team has huddled near or outside the sideline — there, the team is obviously NOT ready.](#)[§]
11. [REFEREE] After one minute (or earlier if both teams indicate readiness to resume), be [near your officiating position for the next play.](#)[†] Verbally inform both teams to get ready (e.g. "Defense, get ready. Offense, get ready"). [Inform the Umpire \(or Centre Judge\) to move to their position, then](#)[†] blow your whistle and give the ready for play signal [S1]. If the duration of the timeout is up, never [ask](#) the teams whether they are ready — [tell](#) them.
12. If a team requests a timeout when all [its](#) have been used, all officials must ignore the request and order the team to play on. [REFEREE] In the rare circumstance where a timeout is granted incorrectly, blow your whistle and signal the ready for play as soon as practicable after the error is detected.

17.2 - Officials' timeouts

1. [REFEREE] If a timeout is not to be charged to either team, face the press box, signal timeout [S3] and then tap your chest with both hands.
2. During an injury or other timeout, carry out the normal duties for a charged timeout, and in addition:
 - (a) stay out of the way of the medical personnel;
 - (b) keep uninvolved players out of the way;
 - (c) ask uninvolved coaches and substitutes to return to their team area;
 - (d) remind coaches not to communicate coaching information to their players while on the field;
 - (e) if necessary, move the ball out of the way while noting the succeeding spot and marking it (if appropriate) with a bean bag.
3. [UMPIRE OR CENTRE JUDGE] Remain with the ball at (or near) the succeeding spot until the Referee informs you to spot it (if necessary) and leave it prior to them declaring the ball ready for play. [◊]
4. ^² [ON-FIELD TIMEKEEPER] Remind the Referee of whether the clock should start on the ready or snap.
5. [REFEREE] As soon as the reason for the timeout has been eliminated (e.g. an injured player has left the field and is in the team area, or well away from the field of play – outside the safety zone – and not in any danger), inform the Umpire (or Centre Judge) to move to their position, then blow your whistle and give the ready for play signal. [†]
6. If an injury timeout is prolonged, or the game is suspended for some other reason, send the players to their team areas.
7. Coach's conference:
 - (a) [REFEREE] Only you can stop the clock for a coach's conference (Rule 3-3-4-e-1).
 - (b) The conference will take place at or near the sideline, or you may invite the coach a few feet onto the field if it would be better to get them away from their team.
 - (c) [DOWN JUDGE, LINE JUDGE, FIELD JUDGE AND SIDE JUDGE] If you are the nearest official on that side of the field, you must go with the Referee to witness the conference.
 - (d) If after the conference the ruling is not altered, the team will be charged with a timeout, in which case the procedure for a charged timeout (including giving the team their full entitlement of time) will be carried out.
 - (e) If a team asks for a timeout which is in fact intended to be a request for a coach's conference and the ruling is then altered, they should only be charged with a timeout if they subsequently request a further timeout.
8. If the game is disrupted for any reason, record the down, the team in possession, the position of the ball and the chain, and the time remaining. In addition:
 - (a) [UMPIRE] [CENTRE JUDGE] Record the lateral position of the ball with respect to the hash marks^²
 - (b) [DOWN JUDGE] Record the position of the chain clip.

18. MEASUREMENTS

1. If you are in doubt whether the line to gain has been reached at the end of a play from scrimmage, blow your whistle, signal timeout [S3] and notify the Referee.
2. [REFEREE] It is your decision as to whether a measurement is necessary or not. Do not be influenced by requests from either team, but take into account the field and field marking conditions. A measurement is more likely when the ball becomes dead some distance from a hash mark because it is more difficult to accurately judge the relationship of the ball to the line to gain.
3. **A measurement may change the tempo of the game, but equally may be essential both to determine whether the line to gain has been reached and to maintain confidence in officials' decisions.** §
 - (a) Because of the importance of the situation after a 4th down play, a measurement should be arranged unless there is absolutely no doubt in anyone's mind as to whether or not the line to gain has been reached. After a 3rd down play, it may be almost as important.
 - (b) **The time remaining in the game should not be a factor in deciding whether or not to measure, but try to avoid measurements when the clock is running during the last 2 minutes of a half after 1st or 2nd down. However, when there is a running clock, be disposed to give the trailing team a first down rather than measure.**
4. For a measurement, the Coverer must place the ball at the precise dead-ball spot – *not* a spot level with that. The ball must *never* be moved from the dead-ball spot until after the measurement is made, in particular the ball must not be moved if it becomes dead in a side zone. If it becomes dead out of bounds it shall be placed at the correct spot on the sideline.
5. [IN xx0 FORMATION (CREW OF 4)] [REFEREE] or [IN xx1/xx3 FORMATION (CREW OF 5/6C/7/8)] [BACK JUDGE] or [IN xx2 FORMATION (CREW OF 6D)] [FIELD JUDGE] Ensure that the ball is at the correct dead-ball spot, and hold it there if necessary. Mark the nose of the ball with a bean bag only if there is a serious risk of it being moved.
6. [IN xx0/2x1/xx2 FORMATION (CREW OF 4/5/6D)] [REFEREE] [IN 3x1 FORMATION (CREW OF 6C)] [CENTRE JUDGE] or [IN xx3 FORMATION (CREW OF 7/8)] [FIELD JUDGE] Ensure that the press box has a clear view of the measurement.
7. [LINE JUDGE] Move quickly to a position on the appropriate yard line to indicate with your foot where the **Down Judge** should place the clip in order to make an accurate measurement (i.e. in a precise north-south line with the ball). When the chain is brought in, there is no need to put your foot on it.
8. **[DOWN JUDGE]**
 - (a) Unless there is a flag on the play, instruct the down box operator to place the down box exactly at the position of the front stake. If there is a flag on the play, [IN xx0/xx1 FORMATION (CREW OF 4/5/6C)] drop a bean bag to mark the location of the front stake. In either case, the number shown on the down box shall be that of the previous down.
 - (b) Grasp the chain at the point where the clip is set and direct the stake operators to bring the chain to the required position on the field. Place the chain so that its position corresponds exactly to that which it occupied on the sideline, which should be marked by the Line Judge's foot. Then call "ready".
9. [SIDE JUDGE] Remain with the down box on the sideline at the front stake and adjust its position once the outcome of the measurement is known. If there is a flag on the play, drop a bean bag to mark the location of the front stake.
10. [UMPIRE] Take the front stake from the operator **when they are a few yards away from the dead-ball spot, position the stake initially a few inches behind the ball** and, when the **Down Judge** calls "ready", gently pull the chain taut **with the stake/chain immediately next to the ball. Try to avoid the stake and chain touching and moving the ball.** §
11. [IN xx0/2x1/xx2 FORMATION (CREW OF 4/5/6D)] [LINE JUDGE] or [IN 2x3 FORMATION (CREW OF 7)] [FIELD JUDGE] [IN 3xx FORMATION (CREW OF 6C/8)] [CENTRE JUDGE] If the measurement is in a side zone, obtain a new ball from a ball person and hold it ready for use.
12. [REFEREE] Determine whether the line to gain has been reached and announce your ruling. Remember that a first down is made if any part of the ball is level with or beyond any part of the front stake.
13. [REFEREE] **On downs 1-3,**° if the ball is short of the first down and outside the hash marks, grasp the chain at the forward point of the ball and position a new ball at the hash mark, using the chain as a guide to placement.
14. [UMPIRE] Once the measurement is completed, return the front stake to the stake operator.
15. **[DOWN JUDGE]**
 - (a) If a first down has been achieved, instruct the chain crew to set up for a new first down. There is no need to return the clip to its previous position.
 - (b) If a first down has *not* been achieved, return the clip to its correct position on the chain clip reference mark and ensure that the chain crew returns the chain to its previous position.
16. [REFEREE] Signal the ball ready for play when the **Down Judge** ensures that the chain is reset in the correct location **and all other officials are in position.** §

19. CALLING FOULS

19.1 - Calling official

19.1.a – Priorities

When observing a foul:

1. Dropping or throwing a foul marker (flag) at the proper spot, i.e. where the foul occurs. lines.
 - (a) Making sure that the flag falls on the correct side of the goal line on spot fouls near either end zone.
 - (b) Throwing the flag high in the air when there is no importance to marking the spot of the foul (e.g. line of scrimmage infractions, dead-ball fouls).
2. Noting the yard line where the foul occurred.
3. Noting the status of the ball, i.e. which team had possession of the ball at the moment the foul occurred, whether it was in player possession or loose, and whether the ball was live or dead.

At the end of the play:

4. When the ball becomes dead, ensuring that all colleagues know that you have thrown a penalty flag.
5. Staying at the dead-ball spot (if you are [also](#)^o the Coverer) until another official relieves you of the responsibility.
6. Consulting with colleagues who also had a flag on the play, or who may have had a better view of the play than you. This is particularly important for targeting fouls.
7. Ensuring that the Referee, Umpire and the rest of the crew are aware of what the foul is.
8. Verifying that the Referee and Umpire enforce the penalty correctly. Staying in the vicinity of the Referee to make sure they have all the necessary information or in case they need a reminder of the player's number. Checking the enforcement spot, the distance, and the direction. If you think anything is wrong, informing the Referee immediately.
9. Recording for each foul you call:
 - (a) the time on the clock (if known);
 - (b) the foul (using the codes listed in section 28);
 - (c) the number of the fouling player;
 - (d) whether the penalty was accepted, declined, offset or cancelled by rule.

19.1.b – Response to what happens (movement and signals)

1. If the ball is live when the foul occurred, do *not* blow the whistle until the ball becomes dead (unless the foul causes the ball to become dead).
2. If the ball is dead or when the ball becomes dead, continue to toot your whistle in short blasts until all other officials know that you have seen a foul. Give the timeout signal [S3] prominently.
 - (a) [If you are the covering official of a score, it is permissible to give the touchdown/field goal signal \[S5\] first before giving the timeout signal, but only if your foul is by the opponents of the scoring team.](#) [§]
3. If the foul is a spot foul, ask an available colleague to cover your flag.
4. [USING O2O/CREW RADIO]
 - (a) If you are the Coverer, remain at the dead-ball spot unless another official takes over responsibility for the spot from you.
 - (b) Use your radio to report your foul(s) to the Referee, Umpire and the rest of the crew.
 - (c) If there are multiple fouls on the play, it may be necessary for all officials involved to gather together in one place (normally, the [previous or dead-ball](#)^o spot) and report them in turn.
 - (d) If there is a Video Judge, using the radio informs them of the situation.
 - (e) If your radio is defective but others' are working, ask a nearby official to report the foul(s) for you.
5. [OTHERWISE]
 - (a) If you are the Coverer, do not leave the dead-ball spot until another official takes over responsibility for the spot from you.
 - (i) If you are not relieved, make the Referee and Umpire come to you.
 - (ii) If you have a foul for defensive pass interference, stay by your flag and make the Referee and Umpire come to you.
 - (b) If you are not the Coverer, once all action has ceased in your area, move quickly towards the Referee and Umpire.
 - (c) [REFEREE] Report the foul to the Umpire. [UMPIRE] Report the foul to the Referee. [OTHERWISE] Report the foul to the Referee and Umpire.
6. Give the following information:
 - the nature of the foul;
 - the offending team, by name and/or colour and/or by offense/defense;
 - the offending player, by number or position;
 - the spot of the foul and the likely enforcement spot;
 - whether the ball was live or dead at the time of the foul and, if appropriate, whether it occurred before or after a change of team possession or while loose from a pass, kick or fumble.

7. Situations where more than one official has a view of the play:[◊]
 - (a) If more than one official throws their flag for a foul (e.g. scrimmage line infractions, interference), all calling officials must consult with each other before reporting the foul.
 - (b) If you have thrown a flag for pass interference, another official may say to you, "Was that pass catchable?" If you are sure it was, reply, "Yes, it was." If you are not sure that it was, reply, "What did you see?" and discuss whether you should or should not pick up your flag. If you have a flag on the ground, the final decision is yours.[◊]
 - (c) Don't assume that everyone saw the same as you.
 - (d) If you have to throw a flag for a foul clearly in someone else's area, it is courteous to discuss it with them.
8. If your flag is for targeting, you must have direct, verbal communication with at least one other official prior to reporting the foul to the Referee. Rarely does targeting occur where there are not multiple views of the action. Because the penalty involves mandatory disqualification, we require this communication to reduce the risk of an incorrect call.
9. When a defensive player, before the snap, moves and an offensive player reacts, a conference between the Umpire and the wing officials is mandatory. This is to determine if the defensive player was in the neutral zone and if the offensive player was threatened.
10. When reporting fouls to the Referee, do not point to teams or players. After reporting, stay near the Referee in case they need to ask you for further details. Avoid conferences except when absolutely necessary to obtain information from more than one official. Only those involved should be included.
11. In the event of a disqualifying foul:
 - (a) Accompany the Referee to notify the Head Coach of the number of the player disqualified and the nature of the foul.
 - (b) It is diplomatic to inform the Head Coach of the disqualification *before* the Referee notifies the spectators.
 - (c) When notifying the Head Coach, the recommended wording is "X just disqualified themselves because ..." or "X is disqualified because ...", rather than "I am disqualifying X because ...".
 - (d) [REFEREE] If you called the foul, the wing official should accompany you.
 - (e) Another official (normally the opposite wing official) should inform the opposing Head Coach of the disqualification.
 - (f) If the foul was due to what a person said or did, all witnessing officials should write down on their game data cards at the earliest opportunity: (i) the exact words used; and/or (ii) what they saw. This is likely to be needed for subsequent disciplinary action and contemporaneous records are more likely to be accurate.[§]
12. When the penalty has been enforced (or declined), retrieve your flag. If the penalty is enforced from the spot of the foul, do not move your flag from the spot until penalty enforcement is completed. It may turn out to be necessary to return to the spot of the foul to correct some error.[§]

19.1.c – Advanced techniques

1. If your flag falls on the wrong spot, move it to the correct spot. Move the flag with authority – don't try to nudge it with your foot in the hope that no one will notice!
2. If there is more than one flag for the same foul, the calling officials should quickly agree which represents the most accurate spot and all other flags should be moved to be on the same yard line as that.[§]

19.2 - Other officials

19.2.a – Priorities

1. If the flag was thrown in your normal area of responsibility, or you believe the penalty may be against a player for whom you were responsible during the down (e.g. your key player at the snap, or a receiver who passed through your area of responsibility), or if you believe there was contact on an uncatchable pass:
 - (a) making sure that you know what the penalty is;
 - (b) reporting any information relevant to it;
2. Not allowing the penalty to be incorrectly administered because someone else did not know what you knew or saw.
3. Sharing an equal responsibility for rule interpretation. If you believe a foul has been called incorrectly, or the penalty administered incorrectly, it is your responsibility to draw this to the Referee's attention without fuss, indiscretion or delay. If you have information to contribute, make sure that your colleagues, especially the Referee, know about it. If an official blows a rule interpretation, the whole crew has blown it.
4. Covering the dead-ball spot if nobody else is doing it. If a ball is not at the dead-ball spot, assisting in getting one there. Leaving the ball on the ground at the dead-ball spot until **penalty enforcement is completed.**[†]
5. [REFEREE] Identifying the official(s) who has/have thrown a flag, going towards them, and finding out the details of the foul they observed.
6. [UMPIRE] Identifying the official(s) who has/have thrown a flag, hearing what they tell the Referee and ensuring that the Referee has understood what they said.

7. [CENTRE JUDGE] Assisting the Referee and Umpire with their penalty enforcement duties.
8. Noting the yard line where the ball is dead.
9. If the foul is a spot foul, covering and holding the spot of the foul. If the foul has post-scrimmage kick enforcement, covering and holding the spot where the kick ends.
10. If other officials are huddling to discuss a situation, keeping players away from them.
11. If all spots are covered, observing the players and assisting where needed.
12. Getting a new ball to the Umpire/Centre Judge.
13. If you are the nearest official to the Head Coach (and you have nothing else to do), standing near them and assisting in communicating to them what the penalty is and what their options are, and relaying their decision to the Referee. This is particularly important when there is:
 - (a) a complex penalty situation;
 - (b) a 10-second runoff option (or a timeout to avoid it).
14. [IN xx0/xx1 FORMATION (CREW OF 4/5/6C)] [LINE JUDGE]
[IN xx2/xx3 FORMATION (CREW OF 6D/7/8)] [FIELD JUDGE] Recording for each foul called: quarter, time, team, player, foul code, calling official(s) and whether the penalty is accepted, declined, offset or cancelled by rule.

19.2.b – Response to what happens (movement and signals)

1. At the end of the play, repeat the timeout signal [S3] given by an official who has thrown a flag.
2. When the Umpire or Centre Judge finishes marching off any penalty,[§] pick up the flag (or bean bag) you are covering and return it to the official who called the foul.

19.3 - Enforcement procedure

1. [REFEREE] After receiving the report of the foul:
 - (a) [USING O2O/CREW RADIO] If the details of the foul have not yet been transmitted[‡] over radio, do so now.
 - (b) If you are unsure of whether a penalty would bring up a first down, use the "penalty yards for a first down" signal [Sup43] to ask the question of the Down Judge.
 - (c) The priority order for deciding whether a penalty (and any related clock option) is accepted or declined is:[◊]
 - (i) whether it is obvious or not (but can be overruled by the team);
 - (ii) ask the Coach;
 - (iii) ask an on-field captain (but they can be overruled by their Coach).
 - (d) If the enforcement and clock option is "obvious":[‡]
 - (i) Inform the on-field captain of the offended team of the foul and where the ball will be placed. You may forgo this if you believe they are already aware of the nature of the foul.
 - (ii) If the captain objects, follow the procedure below for "non-obvious" enforcement. If the captain makes an obviously inappropriate choice, confirm that they fully understand the ramifications of it.[‡]
 - (e) If the enforcement or clock option is not obvious:[‡]
 - (i) Give the preliminary signals in a crisp clear manner to the press box side only.[‡]
 - (1) Preliminary signals consist of (i) the signal for the foul; and (ii) point to the offending team's end line.
 - (2) If there is potential confusion as to whether a foul is live- or dead-ball, give the dead-ball signal [S7] before giving the foul signal for each dead-ball foul.
 - (3) Do *not* announce the foul to the public [USING PUBLIC RADIO] at this stage.
 - (ii) If a sideline official has not obtained the option from the non-offending Head Coach,[◊] explain the foul and options to the on-field captain. If they wish to consult their Head Coach, allow them to do so by shouting or signals (but not by going over to speak to them). While you are consulting the captain, if it becomes clear what the Head Coach's choice is, go with that. If the captain and Head Coach make conflicting choices, go with the Coach's.
 - (f) Notify the on-field captain of the offending team of the foul called and, if possible, the number or position of the offending player.
 - (g) Notify the on-field captain and Head Coach of each team if the penalty involves the loss of a down.
 - (h) If they do not already know, instruct the Umpire and Centre Judge (and [USING O2O/CREW RADIO OR OTHERWISE] other officials) as to the spot of enforcement and the yardage to be marked off.
2. [DOWN JUDGE, LINE JUDGE, FIELD JUDGE AND SIDE JUDGE] If the penalty enforcement (or clock option) is not obvious:
 - (a) If you are the official who is nearest to the Head Coach of the offended team, attempt to get the options from them. **But, if you are the Coverer, you must never leave the dead-ball spot to do this.**[◊] Explain to the Coach[‡] what the foul was and what the options are. **If the coach is not paying attention and/or cannot be easily summoned, inform the Referee that the Coach's input is not currently available.**[§]
 - (b) Communicate by radio, signal (e.g. gesturing towards the chosen spot) or shout to the Referee whether the choice is to accept or decline the penalty (or, in the case of more complex enforcement, which penalty if any the Coach wishes to accept).

3. [UMPIRE OR CENTRE JUDGE]
 - (a) [IN 3xx FORMATION (CREW OF 6C/8)] The Umpire and Centre Judge should work in cooperation to do the following. It does not matter much which official performs each specific task, but they must communicate together to ensure that all the tasks are done and none are duplicated. (**Exception:** only the Umpire should move the ball on penalties enforced from the previous spot on free kick plays.)
 - (b) Ensure that you know what the foul is that has been reported to the Referee.
 - (c) If the acceptance/declination of the penalty is not obvious, call a captain of the offended team while the Referee gives the preliminary signals, so that they may be notified of the foul and the options. If the penalty is complex or may involve options for both teams, call both captains.
 - (d) Obtain a new ball. Other officials may assist in relaying one to you. Hold it in your hand rather than place it on the ground. The ball should only be placed on the ground once penalty enforcement is complete.
 - (e) Be present if the options are given to the offended captain, and check that they are given correctly.
 - (f) **Once you know that the penalty is accepted, check the correct enforcement spot, and calculate the yard line and lateral position to which the penalty will move the ball. Then,[†] while carrying a ball, move directly to the spot, without stepping off each yard of the penalty. (It should only be necessary to step off the penalty on badly marked fields.) If there are multiple penalties enforced, do this separately for each one. If all penalties are declined, confirm you know the succeeding spot and move directly to it. [†]**
 - (g) Before enforcing a penalty(ies) from the previous spot on a free kick, repeat the Referee's penalty announcement signals to the press box.
 - (h) Error prevention procedures:
 - (i) Before starting, confirm with the Line Judge **and/or Down Judge** that you have the correct enforcement spot.
 - (ii) [USING O2O/CREW RADIO] You may transmit the distance, enforcement spot and succeeding spot (MOFO 25.4.4). This needs to be timed to avoid the Referee's penalty announcement.
 - (iii) When you reach the succeeding spot, confirm with the Line Judge **and/or Down Judge** that you have moved the correct distance.
 - (iv) **Place the ball on the ground once you have confirmed[‡]** that you are at the right spot.
 - (v) Do not delay by waiting for the Line Judge **and/or Down Judge** to be in position at the spot they are checking. **Wherever they are,[‡]** they should be able to give you confirmation verbally or by signalling.
 - (vi) When a penalty is enforced from the previous spot on a free kick, the official(s) responsible for confirming the penalty enforcement with you is/are the official(s) on Team A's restraining line (normally the Back Judge, but others may be responsible when in inside-kick formation).
4. [ON-FIELD TIMEKEEPER] If there is less than **two minutes[®]** remaining in the half, ensure that the rest of the crew know that a 10-second runoff may apply.
5. If a 10-second runoff option applies:
 - (a) [REFEREE] If the 10-second runoff option is not obvious, give the option to the relevant captain.
 - (b) [REFEREE] If the 10-second runoff option is chosen and the other team has a remaining timeout, ask its captain whether they wish to use a timeout.
 - (c) [DOWN JUDGE, LINE JUDGE, FIELD JUDGE AND SIDE JUDGE] If you are the official nearest to the relevant Head Coach, attempt to get the option from them and communicate it to the Referee. **But, if you are the Coverer, you must never leave the dead-ball spot to do this. [◇]**
 - (d) If the 10-second runoff option is chosen:
 - (i) [ON-FIELD TIMEKEEPER] Adjust your clock accordingly.
 - (ii) [REFEREE] Remind Team A that the clock will start on the ready for play.
 - (iii) [UMPIRE OR CENTRE JUDGE] Make sure the snapper knows that they must not snap the ball before the Referee signals the ready for play.
 - (e) If the 10-second runoff option is declined:
 - (i) [REFEREE] Remind Team A that the clock will start on the snap.
6. [DOWN JUDGE] Be prepared to respond to the Referee giving the "penalty yards for a first down" signal [Sup43] to you. Answer yes (or nod or give thumbs up) if the enforcement of the penalty from the previous spot would give a first down. Answer no (or shake head or give thumbs down) if not.
7. Error prevention procedures:
 - (a) [DOWN JUDGE AND LINE JUDGE] Listen for the Umpire or Centre Judge transmitting the distance, enforcement spot and succeeding spot, or you may transmit it yourself (avoiding the Referee's penalty announcement). Check with them if you do not think they are correct.
 - (b) [LINE JUDGE] Confirm that the penalty(ies) is/are enforced from the correct enforcement spot. Verbally or visually confirm to the Umpire or Centre Judge that they are starting from the correct position. Also check that the ball has been moved the correct distance (including half distance enforcement). Hold the enforcement spot until the enforcement is complete, except in the following situations:
 - (i) penalties enforced from the previous spot on a free kick;
 - (ii) [IN 2x0/2x1 FORMATION (CREW OF 4/5)] when you are responsible for covering the end of a kick. Note that checking penalty enforcement is a higher priority than (i) covering a penalty flag; (ii) talking to coaches.

- (c) [DOWN JUDGE] Confirm that the penalty(ies) is/are enforced to the correct succeeding spot. This process does not require you to move in synchrony with the Umpire or Centre Judge, but you must check that you both end up at the same yard line and that the correct distance (including half distance enforcement) has been moved. Verbally or visually confirm to the Umpire or Centre Judge that they are finishing at the correct position. Do not move the down box until the enforcement is confirmed as correct.
- (d) [BACK JUDGE OR OTHER OFFICIALS ON TEAM A'S RESTRAINING LINE WHEN IN ONSIDE-KICK FORMATION] For penalties enforced from the previous spot on a free kick, check that the penalty is enforced from the correct spot and that the ball is moved the correct distance (including half distance enforcement). Verbally or visually confirm to the Umpire that they are finishing at the correct position.
8. [REFEREE]
- (a) While the Umpire or Centre Judge is enforcing the penalty, move to a position in clear view and give the final signals to the press box side of the field only. (The Head Coach on the opposite side will be notified by the **Down Judge** or Side Judge). Don't take too long to get into position, though occasionally taking an extra second can help you compose yourself and think about what you are going to say. Come to a complete stop before starting the announcement. **Provided you are in clear view, there is no need to move towards the press box sideline unless:**[◊]
- (i) [NO PUBLIC RADIO] you need people to better hear what you say (e.g. it is a complex announcement); or
- (ii) you are announcing a disqualification of someone from the team on the press box side of the field.
- (b) For each foul, give the appropriate signal and then point towards the offending team's goal line.
- (c) In the case of the following penalties, precede the appropriate signal by the personal foul signal [S38]:
- (i) face mask [S45]
- (ii) roughing the passer [S34]
- (iii) horse collar tackle [S25]
- (iv) roughing the kicker/snapper/holder [S30]
- (v) chop block [S41]
- (vi) targeting [S24]
- (vii) blind-side block [S28]
- (d) If the penalty is declined, also give the penalty declined signal [S10].
- (e) If there are offsetting penalties, signal the home team's foul, point to that team's goal line, then signal the away team's foul, point to that team's goal line, and finally give the offsetting penalty signal [S10].
- (f) **If there are multiple live-ball fouls that will not offset, signal any that are declined before signalling the accepted live-ball foul. Then signal any dead-ball fouls in order of occurrence.** [Ⓜ] For brevity, the numbers of the players may be omitted if there are more than two fouls.
- (g) **If a player is disqualified as a result of a foul, follow the foul signal with the disqualification signal [S47].** [Ⓜ]
- (h) [USING PUBLIC RADIO OR OTHERWISE] **Simultaneously with signalling each foul/penalty, announce it. Include the identity of the offending player by number (or position if the number is not known).**
- (i) [USING PUBLIC RADIO] If you are provided with a radio microphone for communication with spectators and/or broadcast viewers/listeners, it is mandatory for you to use it provided you have a control switch.
- (ii) [NO PUBLIC RADIO] **If there is no radio microphone, speak as loudly and clearly as you can.** [Ⓜ]
- (iii) If the foul is the first unsportsmanlike conduct against an individual, announce that fact as a warning against their future conduct.
- (iv) **When announcing a disqualification, use the same words suggested for use when informing their Head Coach (MOFO 19.1.b.11.c).**
- (i) **If a penalty flag is to be disregarded, give the disregard flag signal [S13] to the press box. [USING PUBLIC RADIO OR OTHERWISE] Announce "there is no foul on the play" or "there is no foul for [name of foul] on the play" and, if possible, a brief explanation as to why the flag is being disregarded.** [Ⓜ]
- (j) **Finally, while facing the press box, indicate the number of the next down.**
9. **Unless penalties for multiple fouls cancel by rule or their net yardage is precisely zero, each penalty distance must be traversed separately and in order. Except for fouls between series, the position of the chain must be reconsidered after each.** [◊] Half distance enforcement should also be checked before each penalty administration. The chain clip, however, need only be set after the last penalty has been enforced.
10. The nearest sideline official on the appropriate side of the field *must* relay to the Head Coach details of the foul if it is by their team, including, where possible, the number or position of the offending player and precisely what the player did that was illegal. If the penalty involves loss of down, the Coach must be notified of that fact. The Coach must also be notified of any unusual enforcements or judgments whether or not they are against their team. Examples might include: flags waved off (disregarded); uncatchable passes; any unfair tactics or unfair acts calls (Rules 9-2-2 and 9-2-3).
11. [REFEREE] If the penalty for a foul is to be enforced at the next free kick, give the final signals (and announce the penalty) and point to the spot of the kick. The Umpire will repeat the signals to the press box before moving the ball.
12. [REFEREE] [USING PUBLIC RADIO OR OTHERWISE] If a penalty enforcement or game situation is complex or unusual, explain it to everyone. Focus on stating facts (e.g. the fouls that were called) and a brief reference to the rule(s) that apply. You may also do this if there are no penalty flags on the play, if the game has already been halted. Do not stop the game just to make an announcement.

19.4 - Obvious and non-obvious enforcement

1. Officials may normally regard enforcement of the following penalties as "obviously" accepted:
 - (a) dead-ball penalties (except possibly those committed by teams about to punt) will be accepted;
 - (b) post-scrimmage kick penalties will be accepted;
 - (c) defensive penalties where the yardage is added to the end of the play will be accepted;
 - (d) Team A penalties that include loss of down will be accepted;
 - (e) Team B penalties that include an automatic first down will be accepted (unless declining gives better field position);
 - (f) Team A penalties that result in a safety will be accepted (unless declining gives Team B the ball in good field position);
 - (g) Team A penalties on plays where they gained a first down will be accepted.
2. Officials may normally regard enforcement of the following penalties as "obviously" declined:
 - (a) penalties where the result of the play is the same as the penalty (e.g. defensive pass interference at the spot of the catch beyond the line to gain, or a safety) will be declined;
 - (b) penalties against the opponents of the team that scores a touchdown (or 2-point try) will be declined unless they carry over to the next free kick;
 - (c) opponent's penalties prior to the offended team gaining possession will be declined;
 - (d) defensive penalties that leave the offense in a less favourable position and less favourable down number will be declined;
 - (e) Team A penalties on plays where they lost significant yardage will be declined.
3. In the following cases, acceptance/declination will be obvious based on the state of the game:
 - (a) where there are multiple penalties, the one that puts the offending team in the worst position will be accepted;
 - (b) where a penalty will extend/terminate the game, it will be accepted/declined according to which team is leading;
 - (c) where a penalty will extend/terminate the first half, it will be accepted/declined according to whether either team is in position to score.
4. Note, however, that a Head Coach or team captain may at any time up to the ready for play overrule the officials' choice of option in the cases above.
5. Officials should normally regard enforcement of the following penalties as not "obvious":
 - (a) where the penalty removes/awards points for a field goal, safety or 1-point try;
 - (b) where better/worse field position has to be traded against more/less favourable down number;
 - (c) where Team B can choose enforcement at the previous spot or the dead-ball spot after a kick (including when an untouched free kick has gone out of bounds) and the length of the kick and/or return does not "obviously" indicate the preferable outcome; generally:
 - (i) a long kick and a short return will suggest previous spot enforcement;
 - (ii) a short kick or long return will suggest dead-ball spot enforcement;
 - (d) where the team last in possession can choose to decline offsetting fouls due to the "clean hands" (Rule 10-1-4 Exception 1) or "postscrimmage kick enforcement" (Rule 10-1-4 Exception 2) rules;[×]
 - (e) where Team A may decline the distance portion of a penalty on a try in order to maintain the same spot for the kicker (Rule 8-3-3-b-2).
6. As well as whether a penalty will be accepted or declined, officials may also regard a team's clock option as "obvious". This covers 10-second runoff situations and whether to start the clock on the ready or snap. "Obvious" situations include:
 - (a) In the closing stages of the game, the team in the lead generally will want to consume time and the team trailing will want to conserve time. An exception to this might be if a lead change is likely to occur in the next play or two.
 - (b) In the closing stages of the first half, a team in a position to score will generally want to conserve time.

20. TIMING AND THE END OF PERIODS

20.1 - Stadium clocks

1. If there are one or more visible game clocks, they will be official. (It would be silly for officials not to use a clock that is visible to the players, coaches, spectators and their colleagues.) To be considered visible, at least one clock must be visible from every spot on the field of play. If not, the stadium clock(s) will not be used. If there are multiple clocks that are not in synchrony, only one or more that are in synchrony will be used and others must be switched off.
2. If there are visible play clocks, they will be official. To be considered visible, there must be play clocks behind each end line, at least one of which is visible to the quarterback from every point in the field of play inside the hash marks. If not, the stadium play clocks will not be used.
3. In most circumstances, the stadium clock operator(s) should start and stop the clock more accurately than anyone on the crew. They should have nothing else to do.
4. [ON-FIELD TIMEKEEPER] Keep your watch in approximate time with the stadium clock. The main reasons for doing this are:
 - (a) in case the stadium clock suddenly goes blank;
 - (b) in case the stadium clock operator forgets to start or stop it, and as a consequence a significant amount of time is lost or gained.
5. [ON-FIELD TIMEKEEPER] You are responsible for checking that the stadium clock starts and stops when it should. Other officials in a better position to view the clock may help you. This is most important if the game clock is behind you. Discuss in the pre-game who is going to do this.
6. Small errors in timing should just be ignored. A few seconds here or there, especially early in a period, are unlikely to bother anyone. Even at the end of a half, an error of a second or two may not matter unless it denies a team an opportunity to score, or gives them an opportunity they should not have.
7. Corrections to the stadium clock should only be made when there is an important or obvious error. An error of less than five seconds per minute remaining in the quarter should be ignored (e.g. an error of 25 seconds can be ignored if there are more than five minutes remaining). A correction should be **announced [USING PUBLIC RADIO OR OTHERWISE]**[@] if it is significant enough to deserve explanation to spectators and teams. This is most likely to be the case within the last two minutes of a half. Otherwise, a correction may be made [USING O2O/CREW RADIO] if the clock operator is able to hear it.
8. When a correction is necessary, it should be made before the next play starts. If an error is not corrected promptly, ignore it and carry on.
9. If the visible clock is malfunctioning (or in very extreme cases, if the stadium clock operator is completely incompetent), the Referee should order it to be switched off.
10. Don't ruin a good game by splitting hairs about the time. It will make you look over-officious, especially if you do it repeatedly.

20.2 - Two-minute warning

1. [ON-FIELD TIMEKEEPER][§]
 - (a) Warn your colleagues that the two-minute warning is approaching and might occur before the ball is snapped. The earliest this is needed is at 2'40 remaining in the half.
 - (b) At 2'00 remaining in the half, or later when the ball is dead, blow your whistle, stop your watch and signal timeout [S3]. (**Exception:** If a touchdown has been scored on the previous play the two-minute warning will be given after the try.)
 - (c) [USING O2O/CREW RADIO OR OTHERWISE] Inform colleagues of the exact time remaining. Remember to do this every time the clock stops for the rest of the half.
2. [REFEREE] [USING PUBLIC RADIO OR OTHERWISE] Announce the two-minute warning and signal it to both sidelines using the two-minute warning signal [Sup45] (Rule 3-3-5-a). Ensure that the on-field captain and Head Coach of each team have been informed of *exactly* how much time remains in the half, not just that it is the two-minute warning.
3. [DOWN JUDGE, LINE JUDGE, FIELD JUDGE AND SIDE JUDGE] If you are nearest to them, inform the Head Coach of the exact time remaining (if there is no visible game clock) and the number of timeouts remaining for their team. [§]

20.3 - Each period

1. When communicating the time to fellow officials, players, coaches or spectators, to increase the likelihood it will be received clearly, say the time twice in two different formats, e.g. "1 minute 34 seconds" and "1, 3, 4".[@]
2. [ON-FIELD TIMEKEEPER] Near the end of each half, whenever the clock stops, [USING O2O/CREW RADIO OR OTHERWISE] ensure that all officials are kept informed of the time remaining. By rule, unless there is a stadium clock, after the two-minute warning in each half, check that the on-field captain and Head Coach of each team is informed of the exact time remaining each time the clock is stopped (Rule 3-3-9-b). If there is a visible clock, confirm that it is accurate.
3. [REFEREE] [USING PUBLIC RADIO OR OTHERWISE] If there is no visible game clock, announce the time remaining whenever the clock stops after the two-minute warning. This should be done from your current position and not take up more time than it takes to say the words.

4. Since there is a possibility that the penalty for infractions of Rule 3-5-3-b after the two-minute warning might include resetting the game clock to the time of the snap, the crew needs to note the time of the last snap.[®]
 - (a) When there are visible game clocks, all officials who have sight of a game clock (without turning their head) share this responsibility.
 - (b) For plays where the clock starts on the snap, all members on the crew share this responsibility, since the time will have just been notified to everyone.
 - (c) [ON-FIELD TIMEKEEPER] When there are no visible clocks, or the clock was running at the snap, you have this responsibility. It is acceptable for this to be an estimate, particularly when the Line Judge is the timekeeper.
5. Responsibility for ruling whether the ball is snapped before or after the period ended:
 - (a) If there are no stadium clocks, the on-field timekeeper is responsible. If their watch does not have an audible or vibration alert, they should raise it in front of their eyes so that they can monitor play and the time concurrently.
 - (b) If there are stadium clocks, the on-field timekeeper should remind the Referee and Umpire that they are responsible. If there is a clock behind each end zone, the primary responsibility rests with the Referee. If there is a clock behind only one end zone, the responsibility rests with whoever is facing it. If the clock is behind neither end zone or it is out of the Referee and Umpire's normal view, an appropriate official has the responsibility. Which official this is should be determined in the pre-game conference.
6. When time expires:[§]
 - (a) [ON-FIELD TIMEKEEPER] If the ball is dead, immediately blow your whistle and signal stop the clock [S3]. If the ball is not dead, do this immediately after the play ends. [USING O2O/CREW RADIO OR OTHERWISE] Inform other officials that time has expired.
 - (b) [REFEREE] Signal the end of the quarter [S14]. [USING PUBLIC RADIO OR OTHERWISE] Announce that time has expired in the quarter/half/game. Don't delay doing this just because you don't have a ball in your hand.
 - (c) [OTHER OFFICIALS] Assist in relaying a ball to the Referee.

20.4 - First and third periods

1. [UMPIRE] Time the intermission between periods.
2. Once the period has ended:
 - (a) [REFEREE] [UMPIRE OR CENTRE JUDGE] Go to the succeeding spot and record (in writing) the yard line on which the ball is placed, its lateral position, the number of the next down and the distance to the line to gain.
 - (b) [DOWN JUDGE] [SIDE JUDGE] Record the yard line on which the chain clip is set, the yard line on which the ball is placed, the number of the next down and the distance to the line to gain.
 - (c) [REFEREE] [UMPIRE OR CENTRE JUDGE] [DOWN JUDGE] [SIDE JUDGE] Do not move from the succeeding spot yard line until you have agreed with each other that you have recorded the correct information.
 - (d) [OTHERWISE] Record the yard line of the ball and the down and distance.
 - (e) [LINE JUDGE] Also record the lateral position of the ball.
3. [UMPIRE OR CENTRE JUDGE] If you are the one with the ball, once you and the Referee have recorded the details and confirmed they are correct, accompanied by the Referee, take the ball across midfield to its new location and re-spot it. [IN 3xx FORMATION (CREW OF 6C/8)] If you don't have the ball, monitor the players as they move to the new location.
4. [LINE JUDGE] Once you have recorded the details, move quickly to the succeeding spot (both yard line *and* lateral position) in the opposite half of the field, and indicate the new location where the ball should next be put into play.
5. [IN xx2/xx3 FORMATION (CREW OF 6D/7/8)] [FIELD JUDGE]
[IN xx0/xx1 FORMATION (CREW OF 4/5/6C)] [LINE JUDGE] Move the alternate down box and line-to-gain marker, but they should remain at their end of period location until you have recorded their positions.
6. [DOWN JUDGE] Once you have confirmed all details are recorded correctly, grasp the chain and the clip, and keeping hold of it, reverse the chain and move it and its crew to the corresponding yard line in the other half of the field. The down box should be moved to its new position at the same time (under the supervision of the Side Judge, if there is one).
7. [SIDE JUDGE] Supervise the down box operator in moving the down box to its new position.
8. [BACK JUDGE] [FIELD JUDGE] Move to the new location for the next play with the players.
9. After completion of these duties, take position for the next play. The ball should not be declared ready for play until one minute has elapsed since the end of the period. This is a "rest" period for the teams and its length should not be varied significantly.

20.5 - Half-time intermission

1. × Half-time notifications:

- (a) [ON-FIELD TIMEKEEPER] Confirm to the Referee the duration of the intermission, the correct time of day, and the correct time that the second half will commence.

- (b) [REFEREE AND/OR CENTRE JUDGE] Remind the offensive team/captain how long the halftime interval is and what time kickoff will be.
- (c) [UMPIRE AND/OR BACK JUDGE] Remind the defensive team/captain how long the halftime interval is and what time kickoff will be.
- (d) [DOWN JUDGE, LINE JUDGE, FIELD JUDGE AND SIDE JUDGE] Remind the head coach on your side of the field how long the halftime interval is and what time kickoff will be.
2. [REFEREE] Do not agree to shorten the intermission between halves unless there is a compelling reason to do so. Remember that half-time is an important rest period for players, coaches, officials and others. Any decision to shorten it must include a risk assessment of its impact on participant safety.
 3. [REFEREE] Signal the start of the intermission by giving the start the clock signal [S2]. [ON-FIELD TIMEKEEPER] Start your watch on this signal. If there is a stadium clock, it too should be started and shall count down the time remaining in the intermission.
 4. Maintain possession of the game balls during the intermission.
 5. Second half options:
 - (a) [REFEREE] [UMPIRE] Not more than five minutes before the end of the intermission, visit each team (in the place where they have spent the intermission, if necessary) and establish the options for the second half. *If the team you visit first does not have first choice of options, ask what they want to do assuming the other team will receive.*
 - (b) [DOWN JUDGE, LINE JUDGE, FIELD JUDGE AND SIDE JUDGE] If the teams are on the field and you are the official nearest to the Head Coach, assist in this by speaking to them and relaying their decision to the Referee [USING O2O/CREW RADIO OR OTHERWISE.]
 - (c) [REFEREE] Ensure that both teams know who is kicking off and which goal each team is defending.
 6. The other officials should go directly to the field and ensure that the chain crew, alternate crew and ball persons are present. The responsible official(s) shall ensure that the game balls are taken back to the field.
 7. [IN xx0 FORMATION (CREW OF 4)] [LINE JUDGE]
[IN xx1/xx3 FORMATION (CREW OF 5/6C/7/8)] [BACK JUDGE]
[IN xx2 FORMATION (CREW OF 6D)] [FIELD JUDGE] Make sure that a ball is available for the kickoff.

20.6 - End of game

1. × [DOWN JUDGE] Recover your chain clip.
2. [UMPIRE] Recover the game ball last used.
3. [DOWN JUDGE, LINE JUDGE, FIELD JUDGE AND SIDE JUDGE] Recover the spare game balls from the ball persons.
4. After the Referee has signalled the end of the game, immediately get together in pairs (or larger groups) and leave the field at a modest and uniform pace (set by the nearest official to the dressing room).
 - (a) If an official is carrying the dressing room key, they should ensure they are the first one to reach the dressing room.
 - (b) You should neither seek nor avoid coaches and players.
 - (c) If hassled by anyone, keep walking.
 - (d) Do not remain on or near the field to chat with players, coaches, spectators or anyone. (**Exception:** if you have been requested to remain for a post-game presentation ceremony.)
5. Any request for discussion regarding the officiating of the game must be directed towards the Referee. [REFEREE] Be prepared to discuss any rules interpretation (in the dressing room, not on the field), but politely refuse to discuss judgment calls. (See also Section 5.3.)[◇]
6. All officials should complete any administrative duties required of them. This includes resolving the correct foul associated with any disqualification that occurred.
7. Officials are responsible after the game to ensure that the balls and any other equipment are returned to game management.

20.7 - Additional duties for live broadcast games

These duties only apply if the game is being broadcast live and the timings of the game need to be synchronised with the broadcast director.

1. All officials should wear a watch. These should be synchronised to the correct time of day during the pre-game conference. [ON-FIELD TIMEKEEPER] [ON-FIELD PLAY CLOCK OPERATOR] Consider carrying a spare watch.
2. Particularly in live broadcast games, it is important that the kickoff is not early and the length of half-time is correct. All officials are responsible for knowing the correct kickoff time, the current time of day and how long remains in half-time.[§]
3. [IN xx1/xx3 FORMATION (CREW OF 5/6C/7/8)] [BACK JUDGE]
[IN xx2 FORMATION (CREW OF 6D)] [FIELD JUDGE]
[IN xx0 FORMATION (CREW OF 4)] [REFEREE] During any timeout or the interval before the start of any period, if there is a TV liaison person near the press box sideline ("red hat" or "orange sleeves"):
 - (a) Stand next to them during the interval until 30 seconds remain. The liaison person may come a few yards on to the field during the interval so that they can be more clearly seen.
 - (b) During each interval, confirm the number of timeouts taken and remaining in the half.

- (c) If it is permitted by the Competition Authority that media timeouts can be granted, the following additional procedure will be used.
 - (i) The number of media timeouts will be agreed at a meeting between the Referee, a game management representative, the TV liaison person and the TV director/producer. This meeting should take place at least two hours before kickoff.
 - (ii) Media timeouts are only granted at the Referee's discretion. However, the Referee must ensure that the agreed number are granted during the game.
 - (iii) During the game, TV liaison can request a media timeout by crossing both arms across their chest.
 - (iv) The Referee will acknowledge that they intend to grant the request by pointing to the ground. The duration of the interval starts when the Referee subsequently gives the TV timeout signal [S4].
 - (v) Media timeouts can only be granted when there is a timeout due to:
 - (1) a charged team timeout, coach's conference or video review;
 - (2) an injury timeout or the Referee suspends the game under Rule 3-3-3;
 - (3) × the end of a period;
 - (4) a score (other than a touchdown – wait until after the try) or an unsuccessful field goal attempt;
 - (5) a change in team possession but not when the ball has been returned to a point on or inside Team A's 20-yard line, or a similar momentum-changing play.
 - (d) Return to your onfield position when there are 30 seconds remaining in the timeout. At the same time, TV liaison will extend their left arm down to their side at a 45-degree angle. These each indicate to everyone that the timeout is near to conclusion.
 - (e) When there are 15 seconds remaining in the media timeout, TV liaison will raise their right hand above their head to signal that the timeout is concluding. The officials near the teams will inform the Head Coach and encourage the teams to get into position and ready to play.
 - (f) At the end of the timeout, TV liaison will drop their arm and point to the Referee.
4. [REFEREE] Do not signal the ready for play until: (i) TV liaison or the Back Judge (or Field Judge) informs you that TV is ready to proceed; and (ii) all officials are in position.

21. USE OF BEAN BAGS

21.1 - General principles

1. All officials shall carry at least two bean bags to use to mark spots other than spots of fouls.
2. Never throw a bean bag overarm. If possible, run to the approximate yard line level with the spot and *drop* it. If this is not possible, toss it underarm.
3. Note the yard line whenever possible.
4. If the bean bag falls on the wrong spot, move it to the correct spot. Move the bean bag with authority – don't try to nudge it with your foot in the hope that no one will notice.

21.2 - Marking spots

1. The Coverer (and no other) shall use a bean bag to mark:
 - (a) the end of a scrimmage kick in bounds. This may be the postscrimmage kick enforcement spot.
 - (b) the spot where possession was lost on a fumble. This is the end of the related run and may be the succeeding spot if the ball goes out of bounds, or the basic spot for fouls occurring during the run or while the ball is loose.
 - (c) the spot where a backward pass is thrown, but only when the pass goes to ground and there is a risk that it may go out of bounds (or no player attempts to recover it).[§]
 - (d) the spot where a backward pass or handoff occurs beyond the neutral zone or when there is no neutral zone. This is the end of the related run and the basic spot for fouls occurring during the run.
 - (e) the spot where an eligible pass receiver goes out of bounds voluntarily. Dropping your hat is an alternative to using a bean bag in this case. This is an indication that a foul will occur should they touch a forward pass in bounds before it has touched an opponent or an official.
 - (f) the spot where a Team A player goes out of bounds during a free or scrimmage kick voluntarily. Dropping your hat is an alternative to using a bean bag in this case. This is an indication that a foul will occur if they return in bounds. (If the player comes back in bounds immediately after going out of bounds a bean bag is unnecessary and you need only drop your flag to mark the spot of the foul.)
 - (g) all spots where a Team A player illegally touches a free or scrimmage kick. These are the spots where Team B may elect to take the ball as the result of the violation. Multiple spots may need more than one bean bag, or use your bean bag to mark the most advantageous (to Team B) of these spots.
 - (h) the spot where a player catches or recovers an opponent's kick, pass or fumble inside or near their 5-yard line when the momentum exception rule may apply. This is the dead-ball spot if the player's momentum carried them into the end zone and the ball subsequently becomes dead in the end zone in their team's possession.
 - (i) the spot of forward progress when the ball carrier (including a sacked quarterback) is driven back (but not routinely – only if there is a problem forming in the pile and you need to leave the forward progress spot to deal with it). This is the dead-ball spot.
 - (j) the spot where a potentially illegal forward pass is thrown.[§]
 - (k) the dead-ball spot if you have to leave the spot to recover the ball or to observe action. This should be a rare occurrence - do not do it routinely. This may include the spot of recovery of a kick by Team A if the recovering player attempts to advance the ball.
2. Unless the spot is also one of the spots listed above, bean bags should *not* be used to mark:
 - (a) the spot where an interception is made;
 - (b) the spot where a free kick ends – give the start the clock signal [S2] if appropriate;
 - (c) the spot where a fumble is recovered;
 - (d) the spot where a kick or pass hits the ground;
 - (e) the spot where a kick is muffed by a Team B player – use the ball touched signal [S11] instead;
 - (f) the spot of a muff in the backfield;
 - (g) the spot of a backward pass in the backfield unless it appears the loose ball may go out of bounds.

None of these can be possible enforcement spots.

22. CHAIN CREW AND BALL PERSONS

22.1 - Chain crew

1. This section lists the instructions that an official (normally the **Down Judge**) gives to the chain crew before the game. Under some circumstances it may be appropriate to delay the kickoff until this is done. Under circumstances that are clearly due to the home team's mismanagement, it also may be appropriate to penalise the home team (Rule 3-4-1-b).
2. Introduce yourself to the chain crew before the game. Note or record their names and use them frequently during the game. Stress to them the importance of their job. Continually praise and thank them, particularly when they do something quickly and promptly.
3. Make the down box operator responsible for the whole crew. Normally, they should be the most experienced person on the crew.
4. Demonstrate to the chain crew the signals that you will use to indicate (i) the down number; (ii) stay!; (iii) move the chain.
5. During the game, avoid handling the chain or down box. Use verbal instructions to the operators to have them move them to the correct position.
6. **Instruct the chain crew never to move the down marker or chain, or change the down number, except at the direction of the Down Judge or Referee.** If they are told to move and they can see that a flag has been thrown, they must stay where they are and draw the official's attention to the flag. When they do move, they must move quickly and with no fuss to their new position.
7. Instruct the crew that the chain never moves on 2nd, 3rd or 4th down; only the down box does. It is also possible (e.g. after a penalty) for there to be a 1st down and for the chain *not* to move.
8. Instruct the chain crew that their expected normal pace is to jog from position to position. In a "hurry up" situation, they should try to move faster.
9. **It is crucial for the safety of players, officials and the chain crew that the sideline be kept clear. The down box and chain *must* be six feet out of bounds, except when setting the chain for a new series. This must be stressed to the down box operator and chain crew.**
10. **It is crucial for visibility by officials, players, coaches and spectators that the down box is always in front of the stake (i.e. nearer the field) (*Exception*: during a measurement). §**
11. Instruct the down box operator that between downs:
 - (a) They must not move until signalled to do so.
 - (b) They must position the down box level with the **Down Judge's** downfield heel.
 - (c) They should change the number on the down box to that indicated by the **Down Judge**.
 - (d) Ideally, they should change the number while moving the box to the new position – i.e. the box should show the old number at the old position, and the new number at the new position.
 - (e) The position of the down box must always be *six feet* out of bounds, except when setting the chain for a new series.
12. Instruct the crew that when a new series of downs is awarded:
 - (a) The down box should be moved first to the spot indicated by the **Down Judge** (the front edge of the stake level with the front of the ball).
 - (b) The chain should then be positioned, setting the rear-most stake exactly **behind**§ where the down box is. The front stake should then be placed to extend the chain to its full length.
 - (c) The down box operator should give hold of their box to the rear stake operator in order that they may position the chain clip. (If a fourth member of the chain crew is available, they may be designated as clip operator). The clip must be positioned *precisely* on the back edge of a 5-yard line, normally the one nearest to the rear stake.
 - (d) Once the clip is set, the chain must be moved *six feet* out of bounds. The chain clip should be positioned on the chain clip reference mark (if there is one) **or the coaching box line (if the chain is within the team area).** ¶
 - (e) **If the down box is not in position at the snap, the Down Judge will drop a bean bag at the sideline parallel with the spot of the snap. The chain crew will line up on this spot. (This should only ever occur late in the game, with the clock running, when the offensive team are trailing and attempting to drive down the field to score.) §**
13. If possible, the chain clip operator or down box operator (or an additional person) should be asked to record the number of the down, **the distance to the line to gain**† and the yard line of each succeeding spot. If this is not possible, it is permissible for the down box operator to use a marker (e.g. a golf tee or a bean bag) to indicate the position of the down box. Finally, the down box operator should be encouraged to memorise the yard line at which they are located.
14. Instruct the crew that if play develops (or seems likely to develop) in their direction they are to move quickly away from the sideline and to drop their equipment to the ground as they go. Emphasise the safety aspects of this, and explain how the chain can be reset using the clip.
15. Instruct the crew that at the end of the 1st and 3rd periods:
 - (a) The **Down Judge** will record the down number, the distance to the line to gain, the yard line and the line on which the clip is set.

- (b) The **Down Judge** will grasp the chain at the point where the clip is set and instruct the stake operator *furthest* from the midfield line to lead the way to the corresponding line in the other half of the field, reversing the chain in the process.
 - (c) The **Down Judge** will position the clip on the correct yard line, then instruct the crew to extend the chain. The chain must then be moved to its position on the chain clip reference points six feet out of bounds.
 - (d) The down box will be moved to its new position as the ball is moved.
16. Instruct the crew that when a free kick takes place they are to remove themselves and their equipment outside the **safety zone**.[®] The chain and down marker should be placed on the ground. They may be told to stand near the receiving team's 20-yard line in order to be near the likely position of the ensuing first down.
 17. Instruct the crew that when a measurement for a first down takes place:
 - (a) The down box is to be positioned where the front stake is located, unless there is a flag down. (This is to provide a backup for the location of the chain.) The number shown on the down box shall be that of the previous down. (If there is a flag down, [IN xx2/xx3 FORMATION (CREW OF 6D/7/8)] the Side Judge or [IN xx0/xx1 FORMATION (CREW OF 4/5/6C)] the **Down Judge** should drop a bean bag at the location of the front stake.)
 - (b) The **Down Judge** will grasp the chain at the point where the clip is set.
 - (c) The **Down Judge** and stake operators will rapidly carry the chain onto the field of play. The front stake operator will hand their stake to the appropriate official (normally the Umpire) **at a point a few yards from the ball.**[§]
 - (d) If a first down is awarded, the stake operators must carry the chain quickly back to the sideline and set up for the new series of downs.
 - (e) If a first down is not awarded and the ball is dead outside the hash marks, the chain will be moved under the direction of the Referee to a position where the ball can be spotted. The Referee will grasp the chain at the point level with the nose of the ball.
 - (f) If a first down is not awarded, the **Down Judge** and the stake operators will quickly return the chain to the sideline. The **Down Judge** will ensure that the clip is accurately repositioned **at the chain clip reference point (if available) or at the sideline and then moved six feet out of bounds (if not).**[§]
 - (g) Once the decision has been signalled by the Referee, the down box will then be positioned level with the front of the ball and the number shown on the down box will be adjusted to the next down, **ensuring the down box is visible in front of any nearby stake.**[§]
 18. When the goal line is the line to gain, or on try downs, only the down box will be used. The chain should be laid on the ground outside the **safety zone**[®] at around the 20-yard line and the stake operators should stand well back for their own safety and so as not to distract the down box operator.
 19. When the chain crew have been instructed in the above procedures, they should be put through a number of trial/dummy runs to ensure that they have understood their instructions. Use whatever time is available before the kickoff to practice these procedures with the chain crew.
 20. Remind the chain crew that, for the purposes of the game, they are officials and must remain impartial. They must not make any remarks to players or express any opinions on official rulings.
 21. If a member of a chain crew fails to perform to an acceptable standard, inform game management that a replacement must be provided.

22.2 - Alternate operators

1. This section lists the instructions that an official (normally the Line Judge or **Field Judge**)² gives to the alternate down box and line-to-gain operators (where available) before the game. Under some circumstances it may be appropriate to delay the kickoff until this is done. Under circumstances that are clearly due to the home team's mismanagement, it also may be appropriate to penalise the home team (Rule 3-4-1-b).
2. Introduce yourself to the operators before the game. Note or record their names. Stress to them the importance of their job. Continually praise and thank them, particularly when they do something quickly and promptly.
3. Instruct the alternate down box operator that they must work approximately six feet off the sideline and that they must mirror the position of the down box on the opposite side of the field. **The auxiliary down box should be moved from its previous spot only when the main down box has been finally positioned level with the succeeding spot. This provides a backup reference point for the last previous spot.**[§]
4. Instruct the alternate line-to-gain operator that they must mirror the position of the stake denoting the line to gain. They too must keep six feet from the sideline. **The auxiliary line-to-gain stake should be moved from its previous position only when the main chains have been finally moved to their new position. This provides a backup reference point for the last line-to-gain.**[§]
5. Remind the alternate operators that, for the purposes of the game, they are officials and must remain impartial. They must not make any remarks to players or express any opinions on official rulings.
6. If an alternate operator fails to perform to an acceptable standard, inform game management that a replacement must be provided or that the alternate operators shall be dispensed with.

22.3 - Ball persons

1. This section lists the instructions that an official (normally the Field Judge or Line Judge) gives to the ball persons before the game. Under some circumstances it may be appropriate to delay the kickoff until this is done. Under circumstances that are clearly due to the home team's mismanagement, it also may be appropriate to penalise the home team (Rule 3-4-1-b).
2. Introduce yourself to the ball persons before the game. Note or record their names. Stress to them the importance of their job. Continually praise and thank them, particularly when they do something quickly and promptly.
3. Appoint one ball person to be responsible for each sideline. In addition each ball person should be made responsible for the end line to their left (when facing the field) in field goal and try situations.
4. Instruct the ball persons that if the ball becomes dead out of bounds, or in bounds outside the nine-yard marks, they are to give a ball as quickly as possible to the nearest requesting official. Normally, on an incomplete pass this will be the wing official and on other plays the deep wing official. If the dead ball goes out of bounds, or is dead because of an incomplete pass, the ball person should then retrieve it. If the dead ball is in bounds the ball person should wait with the Coverer until it is no longer required and then take it off the field.
5. Instruct the ball persons that they must keep up with the play at all times, normally staying near the position of the wing official on their side of the field. On each play, they should start just to the Team A side of the wing official or one-third of the way between the wing official and deep wing official. Instruct the ball person at all times to stay further out of bounds than the nearest official.
6. Instruct the ball persons that on field goal and try attempts, the one responsible for that end line should place their ball at the foot of a goal post and take position well behind the posts in order to recover the ball after the kick.
7. Instruct the ball persons that in inclement weather or field conditions they must ensure that their ball is kept dry and clean. It is the responsibility of game management to supply towels for this purpose.
8. Inform the ball persons that they may be asked to retrieve an official's bean bag if it has been dropped some distance from the end of the play. Instruct them that they must never touch a bean bag without being asked to do so.
9. If you have more than one ball person on your sideline, one should be made responsible for holding the spare ball and feeding it to the officials, and the other made responsible for retrieving the ball last in play [and relaying it to the ball holder ready for next use.](#) §
10. Remind the ball persons that, for the purposes of the game, they are officials and must remain impartial. They must not make any remarks to players or express any opinions on official rulings.
11. Instruct the ball persons not to give balls to players. Players may not practice with nor interfere with the game balls.
12. If a ball person fails to perform to an acceptable standard, inform game management that a replacement must be provided.

23. MECHANICS FOR CREW OF 3

The fewer officials there are the more likely it is that some play action or foul is going to go unobserved. The key to crew of 3 officiating is to recognise what duties are of highest priority and be prepared to omit lower priority ones when time is short.

23.1 - General

1. The officials must decide among themselves who is going to be responsible for briefing stadium clock operators, commentators, chain crew, alternate crew and ball persons.
2. The officials should agree clock operation duties. Normally the Line Judge will run the game clock and the Referee the play clock and timeouts.
3. All officials must be prepared to adapt to play circumstances. The crucial aim is to keep the play boxed in so that it can be observed from more than one angle.
4. On measurements, the Line Judge must take the front stake and the **Down Judge** position the clip. The Referee must ensure the ball is not moved, before moving to rule on the measurement.

23.2 - Free kicks

1. The Line Judge should be on the press box sideline on Team A's restraining line. The **Down Judge** should be on the opposite sideline on Team B's restraining line. These two have responsibility for their respective sideline, and for marking forward progress on the return. The Referee should be downfield in the centre of the field covering the goal line.
2. **The Line Judge should hand the ball to and brief the kicker.** §

23.3 - Scrimmage downs

1. This formation has the advantage that it incorporates the normal positioning adopted by officials on a crew of 4, except that it omits one of those officials (usually the Umpire).
2. The **Down Judge** and Line Judge begin in their normal positions. They are jointly responsible for the line of scrimmage. They are responsible for their sideline on both running and pass plays, and must move to either goal line if that is threatened. On pass plays, once they are confident a pass is going to be thrown that will definitely cross the neutral zone, they may go downfield to observe receivers and whether the pass is complete or not on their side of the field.
3. The Referee begins in their normal position, except that they may choose to begin in the Umpire's normal position if it is necessary to observe interior line play from the defensive side of the neutral zone. On running plays they should observe blocking from the inside out. On pass plays, they are entirely responsible for action in the vicinity of the passer. After the ball is thrown, they are responsible for the protection of the passer and must not turn to observe the pass (even if in the Umpire position).

23.4 - Goal line plays

1. On goal line plays, the **Down Judge** and the Line Judge should be in position to move to the goal line at the sideline, officiating the play from the outside in. The Referee should observe the play from the inside out.

23.5 - Punts

1. The **Down Judge** begins in their normal position and performs their normal duties.
2. The Line Judge must drop deep downfield to the position normally adopted on a punt play on a crew of 4. They must be prepared to rule on the end of the kick and the ensuing return.
3. The Referee should favour the press box side of the field and observe action against the snapper and then the kicker.

23.6 - Field goal & try attempts

1. One official, normally the Line Judge, should be behind the goal and is entirely responsible for ruling on the success or failure of the field goal attempt.
2. The Referee must favour the press box side of the field and be responsible for that sideline should a run or pass develop. They should observe action against the kicker and holder.
3. The **Down Judge** is responsible for action against the snapper and may come infield after the ball is snapped to better observe this.

24. VIDEO REVIEW/INSTANT REPLAY

24.1 - Introduction

1. The sole purpose of video review is to get the call right. However, its use needs to be infrequent because otherwise spectators and participants may get bored or lose confidence in the officiating. IFAF Rule 12 sets out the boundaries of review.

24.2 - Before the game

1. [VIDEO JUDGE] Inform the on-field officials of your location and what facilities (technical and otherwise) you have for reviewing plays. Take the following factors into account when establishing your location:
 - (a) Ideally, you will be in a location where you can get a good, clear view of the whole field as well as your video monitor(s). **We strongly recommend that you stand or sit in a position where you can see the whole field with your naked eye.** [◊] Being able to see the field allows you to see the whole context of the play: down and distance, field position, substitutions, formations, gain or loss on the play, etc. If you can only see your monitor(s), it is harder to establish **all of the** context of a play.
 - (b) Ideally, you will be in a location that is protected from adverse weather and direct sunlight.
 - (c) Ideally, you will be close to the technical staff supporting the video review technology.
2. [VIDEO JUDGE] Determine which sources of video are to be used during the game.
 - (a) **Determine which (if any) sources can be viewed in slow motion and what slow motion speeds are available.**
 - (b) **Determine which (if any) sources can be synchronised and viewed at the same time (split screen or on multiple screens).**
3. [VIDEO JUDGE] If replay is under the control of the television production team, liaise with them and agree procedures to:
 - (a) inform them that a review is to take place
 - (b) inform them which of multiple views you would like to be replayed and at what speed
 - (c) have them inform you if there is a technical problem that prevents replay being used or reduces its capability
4. [VIDEO JUDGE] Liaise with your Video Assistant (if available) and agree what procedures will be used to ask them to perform specific actions such as enabling a specific view to be played back.
5. All officials should review the procedures for stopping the game and conducting reviews.
6. Discuss what types of play and/or what areas of the field are likely to be capable of review. For example, if the only camera is on the midfield line, it is unlikely to be of much help with goal line rulings.
7. [USING O2O/CREW RADIO] All officials should check that communication between the on-field officials and the Video Judge is working satisfactorily.
8. [REFEREE] If there is no Video Judge but replays can be shown on a stadium screen **or on a monitor set up near the field of play,**[®] agree procedures to use to request replays to be shown. **Ensure that the facilities meet all requirements (Rule 12-2-1-d).** Remember that this form of replay must not be used if the choice of whether to show replay or what replay to show is in the control of one team only.

24.3 - Informal review

1. Informal review is an official-only process that facilitates the decision as to whether to stop the game for a formal review. Informal review is intended to be a quick and efficient process that does not delay the game. It can also be used to quickly "fix" problems that the Video Judge has spotted. The results of an informal review are not shared with spectators, but may, if appropriate, be communicated to a Head Coach if time and opportunity permits.
2. While the ball is dead and all action has ceased:
 - (a) [VIDEO JUDGE] You may choose to replay the video of the previous play if you are able to before the next play is likely to start.
 - (b) [ON-FIELD OFFICIALS] You may choose to review the previous play in your mind or discuss it with other officials, if you are able to before the next play is likely to start.
3. Notwithstanding paragraph 24.3.1, in the following situations, the on-field officials may be able to "stall" play for a short while to enable a replay to be viewed by the Video Judge and for a decision to be made as to whether to formally stop the game:
 - (a) during an injury timeout or stoppage for another reason
 - (b) when ball relay is not straightforward

Note that under no circumstances should the officials attempt to stop Team A from putting the ball in play when the play clock is running.
4. If you suspect an error was made, and there is not time to review the play, you must decide whether to stop play, based on:
 - (a) your judgment about the impact of the call/no-call;
 - (b) the likelihood of there being evidence to change the decision;
 - (c) the degree of certainty you have that an error was made (the more certain, the more likely you should be to stop the game; the more doubt, let play continue).

5. Informal review can also be used to supplement information known by officials on the field. This would not normally involve any delay to the game. Examples include:[§]
 - (a) the correct dead-ball spot
 - (b) the number of a player who committed a foul
 - (c) the chronological order of events in different parts of the field, including:
 - (i) whether a foul occurred when the ball was live or dead
 - (ii) whether a foul occurred before or after a change of possession

24.4 - Formal review

1. Formal review is a process that suspends the game while the Video Judge conducts an examination of the video evidence from the previous play. The Referee announces the initiation of a review, what about the play is primarily being reviewed, and finally announces the review's outcome.
2. Any official, including the Video Judge, may stop the game if they believe:
 - (a) There is reasonable evidence to believe an error was made in the initial on-field ruling, and
 - (b) The play is reviewable (Rule 12-1-2), and
 - (c) The outcome of a review would have a direct, competitive impact on the game. Review shall not be used when there would be no competitive impact on the game, including when the running clock rule is in force (Rule 3-3-2).
3. Do not initiate a review in a situation when it would give one team an advantage with respect to time (on either the game clock or play clock).
 - (a) Do not immediately initiate a review in situations where:
 - (i) Stopping the clock would give Team A another play in circumstances where otherwise a period would end.
 - (ii) Stopping the clock would prevent Team A from committing a delay of game foul that looks inevitable.
 - (b) It is however possible to initiate a review after the period has ended or the play clock has expired and, if a call is changed, the game clock would be restored to the point it would have been at if the call had been made correctly and the play clock would be reset to 25 seconds.
4. To stop the game:
 - (a) [ON-FIELD OFFICIALS] Blow your whistle and signal stop the clock [S3]. Once any action has ceased, [USING O2O/CREW RADIO] say clearly, "stop the game; stop the game; video review." All other officials should echo the stop the clock signal [S3].
 - (b) [VIDEO JUDGE] [USING O2O/CREW RADIO] Say clearly, "stop the game; stop the game."
5. If a Head Coach requests a review, inform the Referee. Any review requested by a coach is a formal review. The Referee and the nearest sideline official should confer with the Head Coach to understand what they are challenging and to ensure that what is being challenged is reviewable.
6. [REFEREE] [USING PUBLIC RADIO OR OTHERWISE]⁹ Announce to spectators that a review is taking place using the video review signal [Sup44].
 - (a) If the review was requested by a Head Coach, announce, "(Team) has challenged the ruling of (whatever)."
 - (b) If the review was initiated by an official, announce the primary ruling that was made. This effectively defines what is most likely to be "changed" by the video review (though other aspects of the play can also be changed). Examples:
 - (i) "The ruling on the field is that the pass was incomplete."
 - (ii) "The ruling on the field is targeting by Red #25."
 - (iii) "There may have been a serious foul on the previous play." (If it is suspected that a foul committed on the previous play was not called on the field.)
 - (c) In either case, follow this by, "The previous play is under review."
7. [DOWN JUDGE, LINE JUDGE, FIELD JUDGE AND SIDE JUDGE] If you are the official nearest to the Head Coach, inform them that a review is taking place.

24.5 - During a review

1. During the review, all the relevant officials who were involved in the call/no-call on the field should gather together with the Referee, away from players if possible. Other officials should keep players clear.
2. If possible, a sideline official should stay close to the Head Coach on each side of the field. This is particularly important if the replay has been requested by the Head Coach. During the review, do NOT inform the Coach of details of the discussion that is taking place. However, you may inform them of important facts that are confirmed or determined.
3. If the review has been initiated from the field, normally an on-field official (or the Referee on their behalf) should ask the Video Judge to answer a specific question of fact (e.g. "Was the ball carrier's knee down?"). If the review has been initiated by the Video Judge, they should inform the on-field officials of which aspect(s) of the play they wish to review.
4. [ON-FIELD OFFICIALS] [USING O2O/CREW RADIO] The primary responsible official should describe in as much detail as possible what they saw. Other officials who saw the relevant action should then describe what they saw.

5. [VIDEO JUDGE] [USING O2O/CREW RADIO] Describe what the video shows. In cases where the video evidence is clear, the description should be brief and to the point. Where the video evidence is inconclusive, describe what you see in sufficient detail so that the group can come to a collective decision about what actually took place.
6. Rule 12-2-3-a states that if there is **clear and obvious**[®] evidence that a ruling on the field was incorrect or that something within the scope of the review procedure occurred and was missed by the on-field officials, the Video Judge will advise the on-field officials to change their ruling(s).
7. Rule 12-2-3-b states that where there is other evidence (e.g. **not clear or not obvious**)[®] the Video Judge shall inform the on-field officials of the evidence available and give them the opportunity to change their ruling(s) when that evidence is combined with evidence from their own observations. The Video Judge may not override the judgment of any of the on-field officials, but may advise them. The final determination of fact(s) shall remain with the on-field officials. If in doubt, the call stands, unless there is sufficient evidence (in the balance of probabilities) to overturn it.
8. [VIDEO JUDGE] When making decisions about false starts and similar timing plays, ensure that the video evidence is clear when played at normal speed. Do not create a foul based only on frame by frame analysis, though this could be used to cancel a foul.
9. If an on-field official definitely saw an action and made a judgment that it was not serious enough to be called as a foul, then the Video Judge should not overrule that judgment unless the evidence of the foul is conspicuous. However, if the calling official quickly changes their mind, then their original decision can be changed on the advice of the Video Judge. The calling official must not allow pressure from participants or spectators to influence their decision - it must be made on the grounds of consistent application of officiating philosophy (Chapter 3).
10. [USING O2O/CREW RADIO] When communicating information, the receiving official should repeat back the most important details to confirm that they have been received and understood clearly. This will be the Video Judge for information transmitted by an official on the field, and normally the Referee for information conveyed by the Video Judge. **Do this away from players and coaches, so that they do not overhear you and thus get advance notice of what is being decided.** §
11. While undertaking a review of a particular aspect of a play, it is perfectly acceptable for other aspects to come under consideration. A review can consider *any* aspect of the play for which the game was stopped. The Video Judge is responsible for deciding which other aspects of the play may be considered, including:
 - (a) whether another serious foul was committed
 - (b) the status of the ball (e.g. that it became dead earlier in the play)
 - (c) timing aspects
12. Avoid facial expressions, gestures or negative body language that might be visible to spectators or television.
13. [IN xx1/xx3 FORMATION (CREW OF 5/6C/7/8)] [BACK JUDGE]
[IN xx0 FORMATION (CREW OF 4)] [LINE JUDGE]
[IN xx2 FORMATION (CREW OF 6D)] [FIELD JUDGE] Act as Replay Field Official (RFO).
 - (a) If the result of the play is changed, record the following details about how play should be resumed, and ensure that all on-field officials are aware of them:
 - (i) number of the next down
 - (ii) distance to the line to gain
 - (iii) yard line
 - (iv) lateral position of the ball (hash mark)
 - (v) game clock time
 - (vi) whether the clock will start on the ready or snap
 - (vii) whether a timeout is to be charged
 If the Video Judge does not know the precise details of any of these, an estimate can be used.
 - (b) **Stay close to the Referee so that you can remind them of this information if they forget while making an announcement. Ensure other officials are aware of the particular information they need to set up for the next play.**
 - (c) **Also, in cases where the Referee can view replays on a monitor near the field of play, go with them to the monitor so that you can:**
 - (i) **be a second pair of eyes on what is shown ("what do you think?");**
 - (ii) **be a second source of rules knowledge and philosophy;**
 - (iii) **keep people away from the Referee;**
 - (iv) **be prepared to act as communicator for any further information that is needed from or provided to other officials.** §
14. In cases where there is no Video Judge but the on-field officials can view replay on a screen, the same procedure should be followed, but should not normally require discussion to take place using radio.

24.6 - Key phrases

1. During a review, it is important to use clear and unambiguous communication that conveys all necessary information, but also lets all parties know what state the process is in. Using the following phrases standardises this communication.
2. Stopping play.
 - (a) **Stop the game; stop the game:** When used by any official, this indicates that the game is to be stopped for a formal review.
3. Exchanging information.
 - (a) **The video shows ...:** When used by the Video Judge, this communicates the facts that can be determined from the video.
 - (b) **What I saw was ...:** When used by any on-field official, this communicates their view of what happened on the field. This can be accompanied by their judgement of, for example, whether an act was intentional or not. [@]
 - (c) **I cannot tell ...:** When used by the Video Judge, this communicates the facts that cannot be determined from the video. This could be an opportunity for an on-field official to inform the Video Judge of what they saw in relation to this.
 - (d) **X, please tell me what you saw relating to ...:** When used by the Video Judge, this is a request for information about a specific aspect of the play. This will normally be directed to one or more specific officials. It should normally begin by referencing the specific official(s) by name. If more than one, it would be helpful if they respond in the same order as they are mentioned in the request. If the Video Judge does not get a response, they should repeat the request. It may be followed by a further request for more detailed or supplementary information. Another on-field official may need to inform the intended recipient(s) of the request if the recipient(s) did not hear it.
 - (e) **V, what does the video show relating to ...:** When used by an on-field official, this is a request for the Video Judge to provide information about a specific aspect of the play. It should normally begin by referencing the Video Judge by name. If the on-field official does not get a response, they should repeat the request. It may be followed by a further request for more detailed or supplementary information.
4. Concluding the review.
 - (a) **I have made my decision - the call [is confirmed/stands/is changed].**[@] When used by the Video Judge, this indicates that they have acquired all the information that they believe they need to determine the outcome of the review (Rule 12-2-3-a). This may be either because there is **clear and obvious**[®] evidence to confirm or reverse a call, or that there is no prospect of gaining such evidence and the on-field ruling stands. This will be followed by details of the decision, emphasising whether the on-field ruling is confirmed, stands or changed, and if changed, to what.
 - (b) **I believe we have a consensus - the call [is confirmed/stands/is changed].**[@] When used by the Video Judge, this indicates that they have acquired all the information that they believe is needed to come to a consensus decision between themselves and the on-field officials (Rule 12-2-3-b). This may be either because there is clear agreement to confirm or reverse a call, or that there is no prospect of gaining such agreement and the on-field ruling stands. Unless immediately contradicted by an on-field official, this will be followed by details of the decision, emphasising whether the on-field ruling is confirmed, stands or changed, and if changed, to what.
 - (c) **The next play will be ...:** When used by the Video Judge, this communicates the necessary information about the next play. This should include all relevant details (MOFO 24.5.13).

24.7 - Conclusion of a review

1. [REFEREE] Check that all relevant members of the on-field crew have been informed of the decision.
2. [DOWN JUDGE, LINE JUDGE, FIELD JUDGE AND SIDE JUDGE] If you are the official nearest to either Head Coach, inform them of the outcome. If the review was requested by the Coach, this is particularly important.
3. [REFEREE] [USING PUBLIC RADIO OR OTHERWISE][@] Announce:
 - (a) "After further review, ..."
 - (b) If the on-field ruling is confirmed, announce, "... the ruling on the field is confirmed."
 - (c) If the on-field ruling stands, announce, "... the ruling on the field stands."
 - (d) If the on-field ruling is changed, announce "... the ruling on the field has been changed," and provide details of (i) why and (ii) what the impact of the changed ruling is. (The word "changed" is much better than "reversed".) Have the RFO stand near to you so that they can remind you of details if you forget them.
 - (e) **If the review was announced as looking at a particular aspect of the play, make sure that your announcement covers this. That is particularly important when the aspect of the play that was changed was different from the aspect that was initially announced. For example, "The pass was confirmed as incomplete, but the review also showed that there was defensive pass interference by Red 23 on the play."** [@]
 - (f) If the review was requested by a Head Coach and the ruling was not changed, announce the charged timeout against that team as normal, but add "(Team) has no further coach's challenge available for the rest of the game."
4. All officials should check that the down and distance, the location of the ball and the time on the game clock have been correctly set.

24.8 - Unavailability of review

1. If due to technical or other problems, it becomes impossible to conduct video reviews:
 - (a) [VIDEO JUDGE] Inform the Referee that video review is not available.
 - (b) [REFEREE] Suspend the game temporarily (Rule 3-3-3) and [USING PUBLIC RADIO OR OTHERWISE] @ announce that video review is not available.
 - (c) [DOWN JUDGE, LINE JUDGE, FIELD JUDGE AND SIDE JUDGE] Inform the Head Coach on your side of the field that video review is not available.
2. While video review is not available, no reviews can be requested.
3. If it subsequently becomes possible again to conduct reviews:
 - (a) [VIDEO JUDGE] Inform the Referee that video review is again available.
 - (b) [REFEREE] Suspend the game temporarily (Rule 3-3-3) and [USING PUBLIC RADIO OR OTHERWISE] @ announce that video review is again available.
 - (c) [DOWN JUDGE, LINE JUDGE, FIELD JUDGE AND SIDE JUDGE] Inform the Head Coach on your side of the field that video review is again available.

25. RADIO COMMUNICATIONS

25.1 - Introduction

1. Use of on-field radio communication (sometimes known as official-to-official or O2O) is strongly recommended where available. †
2. Radio equipment must conform to the technical requirements of the country in which the game takes place. In addition:
 - (a) The use of a headset is mandatory – you need to keep what you hear private and your hands free during the game.
 - (b) Voice activated or "open-mic" radio communications should not be used, since this is likely to clutter the airwaves with noise. "Push To Talk" style radio communications should be used.
3. Radio communications should only be used by officials actively involved in the game. ^λ These include:
 - (a) on-field officials;
 - (b) Video Judge and Video Assistant;
 - (c) alternate officials;
 - (d) assessors;
 - (e) off-field officials acting as a "buddy"/trainer to on-field officials;
 - (f) officials attending the game in an official supervisory or training capacity;
 - (g) officials working as a timekeeper or scoreboard operator;
 - (h) officials working as chain crew or ball personnel;
 - (i) officials working in a media liaison role;
 - (j) prospective officials attending a game to observe the officials (if the crew agrees).

It is appropriate to share radio communications with fellow officials (or prospective officials) in order to facilitate education and aid in observing how the officials work. @
4. Radio communications should not be used by or shared with any non-match officials.
5. If separate crews are working games at the same venue (e.g. a finals day or bowl weekend), as a matter of courtesy, either the succeeding crew should not use or test their radios until the previous crew has finished its game or else the succeeding crew should ensure they are using a different frequency. ×
6. If it is found that any non-official (player, coach, spectator) is listening in to or recording the on-field crew radio communication without permission (eavesdropping), this should be reported as it is in conflict with the spirit of Rule 1-4-13-c. ^λ

(Note: It is reasonable for coaching staff or game management to have their own radios to communicate amongst themselves. If you discover that you are ^λ accidentally using the same frequency/channel, change channel. This is not an infraction of Rule 1-4-13-c.) ^λ
7. **Be aware at all times that somebody might be listening to what you say, so be professional.**

25.2 - Before the game

1. In the week before the game, the Referee should remind everyone that radios will be used and that they should recharge the batteries. At least one official should bring a charger with them to the game in case anyone forgot to do that.
2. In the pre-game, agree what channel to use (and at least one backup to switch to if there are reception or other problems). Regular users will be able to tell when reception is poorer than usual – usually demonstrated by hearing static or other people's voices, or failing to hear other members of the crew clearly. @ This should prompt trying out a different frequency.
3. Before leaving the dressing room for the field and/or when on the field, test that everyone can receive everyone else. After the Referee initiates the test, each other official should, in turn, speak to confirm they have heard all the previous official(s) on the list. ^λ Transmission order: R, U, D, L, B, F, S, C, V.

25.3 - Mandatory uses

The following uses are compulsory (by any member of the crew, unless specified):

1. Relay the game clock time and status.
 - (a) "Time remaining?" Timekeeper (only) should reply.
 - (b) "Ready or snap?" Covering official (only) should reply.
 - (c) Is this a 10-second runoff situation ("Why did the clock stop?").
 - (d) If there is no visible game clock,
 - (i) Wing officials should relay the game clock time to their sideline; R and U to offense and defense, where possible.
 - (ii) Relay the mandatory Rule 3-3-9-b notification every time the game clock stops in the last two minutes of each half.
 - (iii) Crews may agree to relay the game clock time at each score, penalty and change of possession.
 - (e) When the timekeeper relays the time, an official (normally the Referee) should acknowledge it by repeating back the time remaining.

2. [BACK JUDGE OR SIDE JUDGE] Transmit the time remaining on the play clock – but it needs to be done at 12 seconds to give the Referee time to relay it to the offense.
3. Foul called, team and number ("False start, red, 73"). If the calling official doesn't transmit this, the Referee should, after it's reported to them and before doing the rest of the enforcement procedure (MOFO 19.3.3.h.ii).
4. [REFEREE] Confirm the score after an extra point, field goal or safety ("Score is now home 21 visitors 7" – home team first). [ON-FIELD TIMEKEEPER] Acknowledge this by repeating back the score.
5. [REFEREE] Tell the crew to switch to onside kick mechanics ("Onside kick; onside kick"). This should be acknowledged by the officials who have to move as a consequence.
6. During instant replay review, and using specified "key phrases" (MOFO 24.6). @

25.4 - Encouraged uses

The following uses are encouraged (by any member of the crew, unless specified):

1. When targeting (or a similar serious foul) is called, the calling official should ask "Did anyone else see the hit on white 84?"
2. The sideline official nearest to the offended coach may transmit the Head Coach's decision to accept/decline a penalty, when enforcement is not obvious.
3. [REFEREE] When there is a potential intentional grounding, ask "Was there a receiver in that area?"
4. [UMPIRE OR CENTRE JUDGE OR LINE JUDGE] Penalty distance, enforcement spot and succeeding spot (e.g. "We're going 10 yards from the 37 to the 27", "We've gone half distance from the 8 to the 4") (MOFO 19.3.3.h.ii). This needs to be timed to avoid the Referee's penalty announcement.
5. [REFEREE] When the enforcement spot for a penalty is not obvious, this should be transmitted to the rest of the crew.
6. Alerts, e.g.:
 - (a) The down box is showing the wrong number ("Down box should be 3").
 - (b) An official is not in position ("Umpire isn't ready").
 - (c) The ball is dead close to the line to gain ("It's close").
 - (d) Who has goal line responsibility ("Wings have the goal line").
 - (e) What type of try Team A looks like attempting ("They are going for 2 points").
7. Reminders, e.g.:
 - (a) Hurry-up offense ("Remember, Umpire needs to go and get the ball if the clock is running.")
8. Mechanics snafus, e.g.:
 - (a) An official is in the wrong position or did something wrong ("Jim, that was your out-of-bounds.")
 - (b) Nobody signalled to stop the game clock at the end of the down ("Do we have a first down?")
 - (c) Nobody made a ruling on the result of the play ("Was the pass complete or incomplete?") §
9. When face to face discussions are taking place, *one* official should press their transmit button so that the rest of the on-field crew and the video judge can hear what is being said. @

25.5 - Potential uses

The following uses are approved on an occasional basis, but should not be used routinely:

1. Confirming cross-field mechanics ("Line Judge has a spot.")
2. When an official needs someone else to talk to a player on their behalf (give some details, briefly) ("Umpire, please ask red 65 to keep their hands inside the frame.")
3. Confirming the details before announcing a penalty (Referee: "What was the player's number again?")
4. Transmitting the yard line the ball is on after a return ("Ball is on the 33 going out.")
5. Transmitting the Back Judge's key (but only if in serious doubt) ("Back Judge has 88").

25.6 - Prohibited uses

The following uses are prohibited:

1. Profanity, anger, opinions of the teams – remember you may be being listened to.
2. When you would interrupt someone else's communications, e.g.:
 - (a) The Referee is giving (or about to give) penalty announcements (unless you urgently need to correct a significant mistake).
 - (b) The Referee (or another official) is talking (or about to talk) to players or coaches.
3. When the ball is live or about to become live – sound your whistle if you need to attract attention urgently and stop play.
4. Ambiguous messages, e.g.:
 - (a) Talking about a team or an action without identifying a team by its name, colour or as offense/defense.
 - (b) Talking about a player without identifying them by team *and* number.
 - (c) Talking about a side or end of the field without being specific.

25.7 - If a radio unit becomes inoperable

1. Continue with the remaining radio units. Any official with an inoperable unit will need special consideration when it comes to communication.

25.8 - General reminders

1. Radio is there to supplement the current mechanics, not replace them.
2. Don't attempt to talk over someone else.
3. Remember to press the button and pause before speaking.

26. AREAS OF COVERAGE

The following diagrams serve to illustrate the principles described in the previous chapters.

They are of two main types:

- static diagrams show the areas of responsibility of each of the officials **at the start of a play**^o — in other words which official has the primary duty to watch the ball and the ball carrier when they are in that area;
- the example play diagrams show the positions of the officials and the key players at various points in time as the play develops.

The areas of responsibility shown are those at the start of the play. As the play develops, these change, usually so that the nearest official is concentrating on the ball carrier and the other officials on the action around them.

In each diagram, yard lines across the field are drawn at five yard intervals.

In each diagram, the position of the Referee (and Centre Judge if there is one) is based on the assumption that the quarterback is right-handed or the kicker is right-footed. If the quarterback is left-handed or the kicker is left-footed then the Referee should be in the mirror position to the left side (**Exceptions:**[†]

1. [IN 3xx FORMATION (CREW OF 6C/8)] where the Referee should stay on the right-hand side of the formation and the Centre Judge on the left; and
2. [IN 3x1/2x2/2x3 FORMATION (CREW OF 6C/6D/7)] where the Referee will need to be on the right on field goal attempts).

Note, however, that if a team suddenly changes quarterback or kicker, it is better for the Referee (and Centre Judge) to officiate from the "wrong" side than to try to swap over hurriedly.

26.1 - Basic free kick areas of responsibility

Figure A: The 8 basic free kick positions

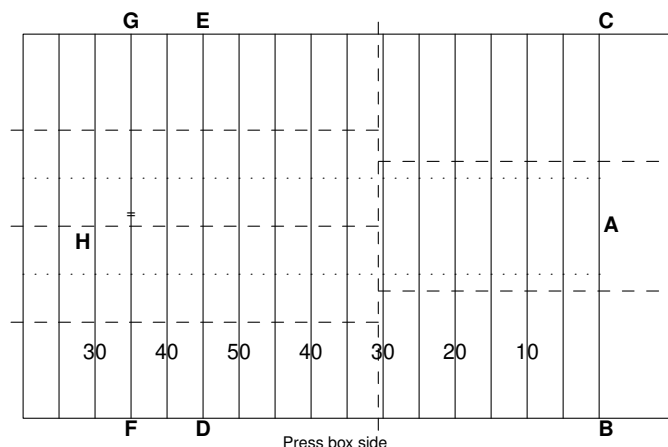

The following table summarises which official is in which position according to the size of the crew and whether it is a normal or onside-kick.

Size	A deep centre	B pylon PB	C pylon OP	D TB RL PB	E TB RL OP	F TA RL PB	G TA RL OP	H with kicker
Normal								
3	R				D	L		
4		L	R		D	U		
5		L	R		D	B		U
6C	R	L	D		C	B		U
6D	R	L	D		S	F		U
7	R	L	D	F	S	B		U
8	R	L	D	F	S	B	C	U
Onside-kick								
3	R				D	L		
4	R				D	L		U
5	R			L	D	B		U
6C	R			L	D	B	C	U
6D	R			L	D	F	S	U
7		L	R	F	D	B	S	U
8	R	L	D	F	S	B	C	U

RL = restraining line; PB = press box side; OP = opposite press box; TA = Team A; TB = Team B

Figure B: Crew of 4 (normal positions)

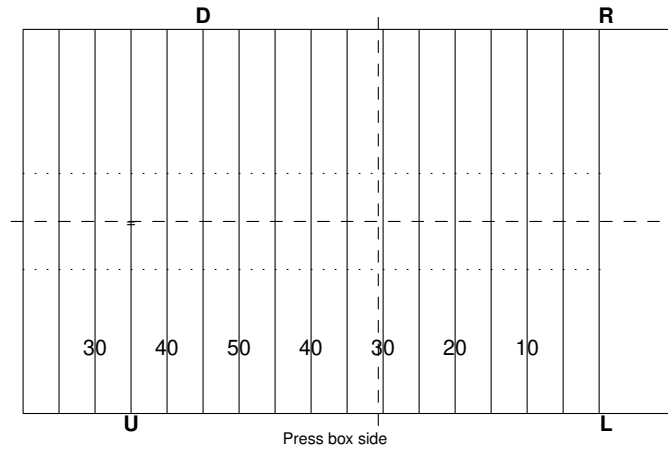

Figure C: Crew of 4 (onside-kick positions)

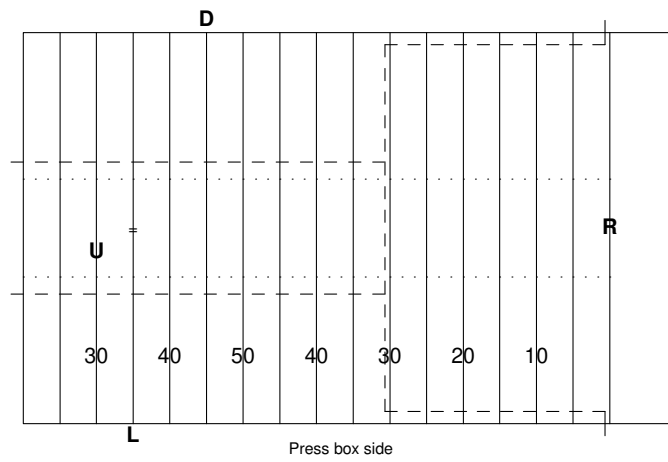

Figure D: Crew of 5 (normal positions)

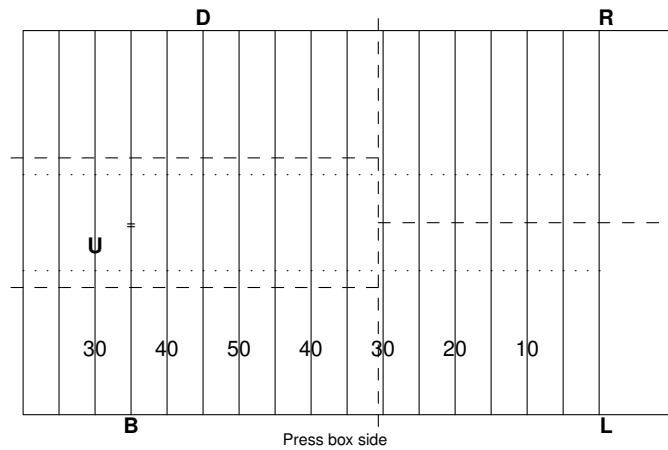

Figure E: Crew of 5 (onside-kick positions)

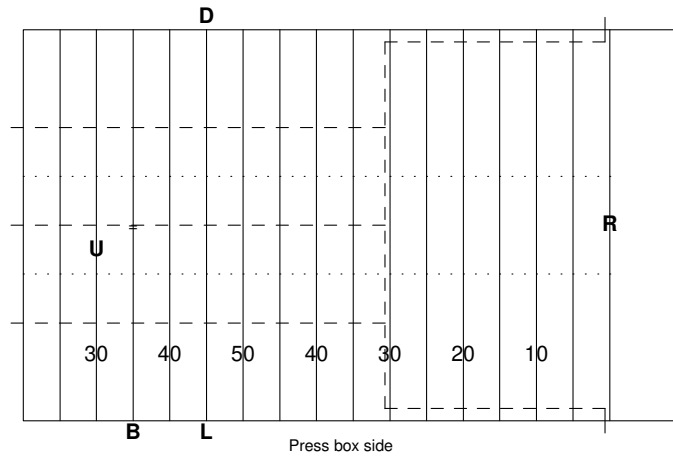

Figure F: Crew of 6 (normal positions)

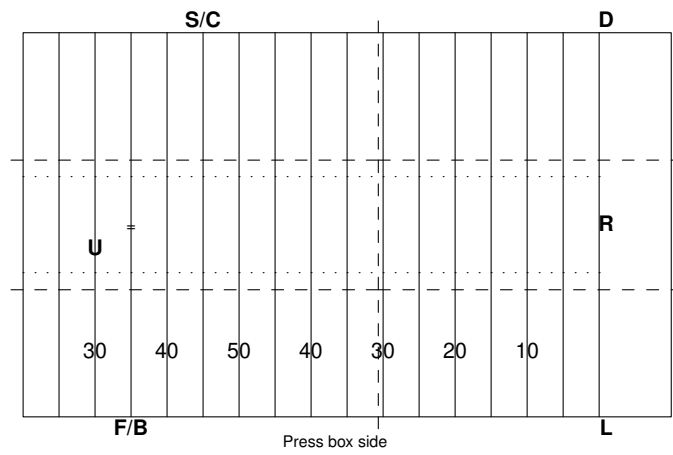

Figure G: Crew of 6 (onside-kick positions)

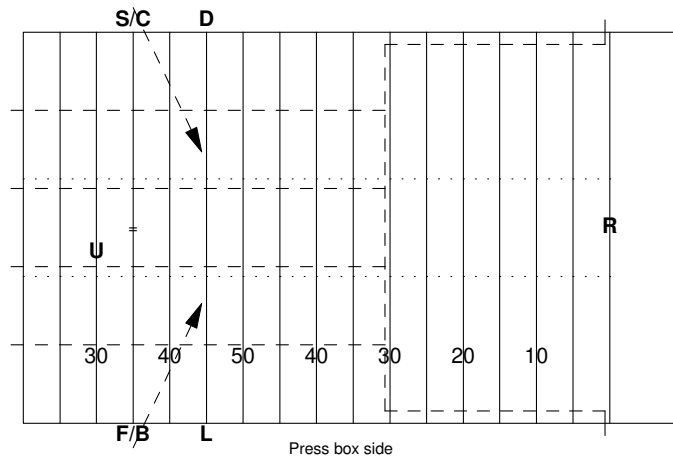

Figure H: Crew of 7 (normal positions)

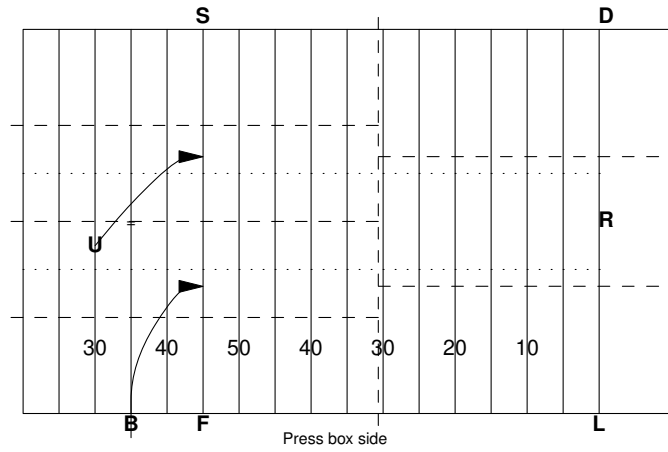

Figure I: Crew of 7 (onside-kick positions)

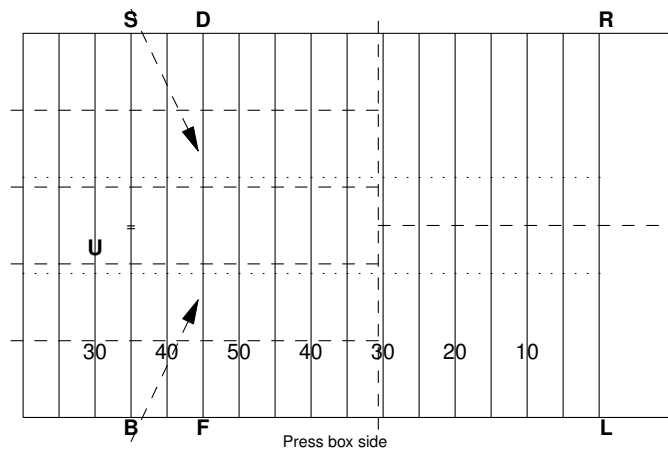

Figure J: Crew of 8 (both normal and onside-kick positions)

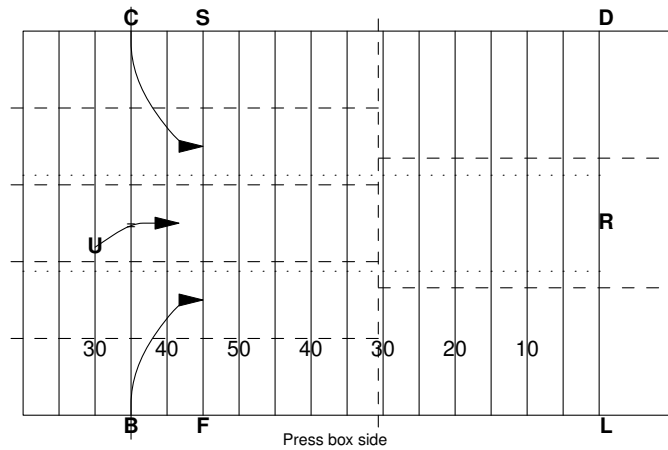
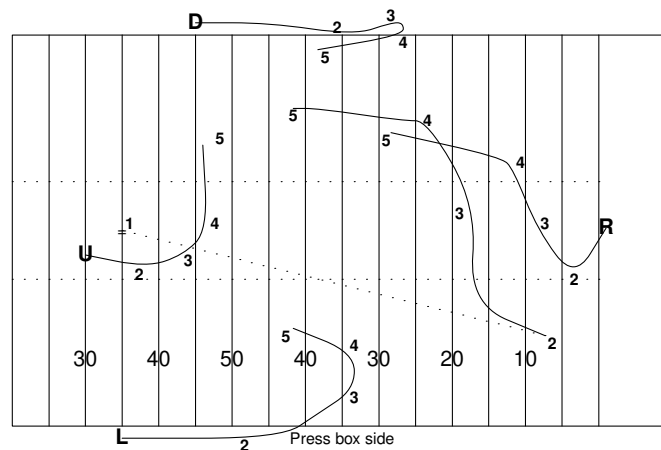
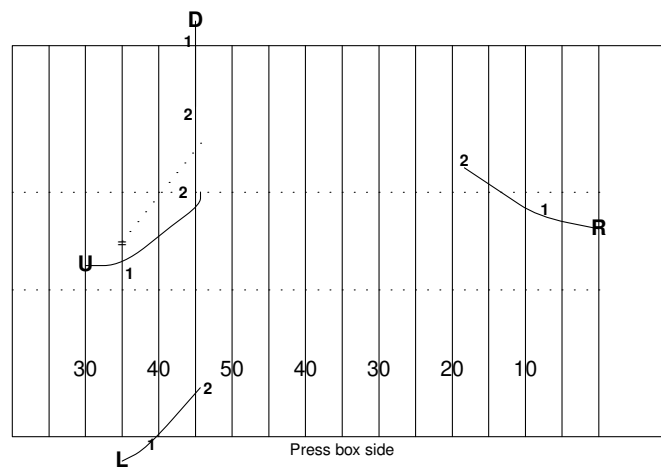

Figure K: Example play (Crew of 4, outside-kick positions) free kick deep to press box side returned across field



As the ball is kicked off (1) the officials are in their initial positions. While the ball is in flight the officials begin to move to cover their areas of responsibility. The ball is descending in the Referee's area so they watch the potential receivers for fair catch signals. The other officials watch the blocks by and against the players moving downfield and for any illegal wedge forming in front of the returner. The Referee observes the catch of the kick (2) and watches the returner while they are in their area. As the returner runs across the field (3), the officials adjust their positions to keep the play boxed in. The Down Judge and Umpire observe lead blocks on the return until the ball carrier moves into the Down Judge's area of coverage (4). At this point the Down Judge takes the ball until the ball carrier is tackled (5) while the Referee switches to watching action around the ball carrier. The Line Judge maintains a wide view of the field.

Figure L: Example play (Crew of 4, outside-kick positions) short kick to Down Judge's side of the field



When the officials see that the ball has been kicked short (1), the Down Judge, Umpire and Line Judge all move into a position to see the ball and action around it. The Referee moves upfield observing peripheral action. When the kick is recovered (2), the Down Judge and Umpire will move rapidly to the dead-ball spot to be prepared to rule on possession. The Referee and Line Judge continue to monitor action around and away from the ball.

26.2 - Basic scrimmage down areas of responsibility

Figure A: Crew of 4

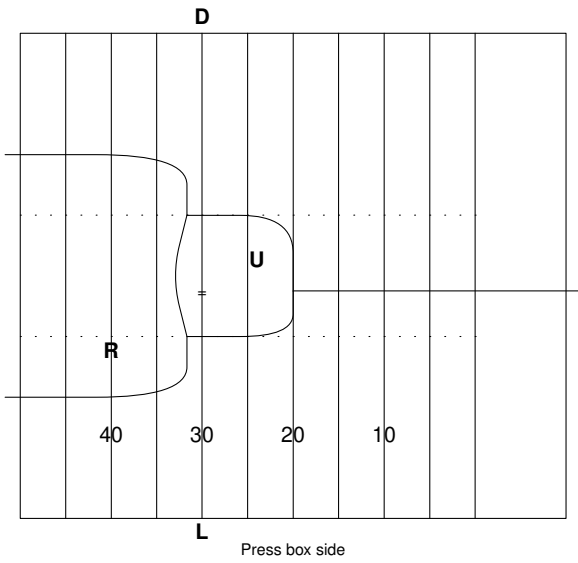

Figure B: Crew of 5/6C

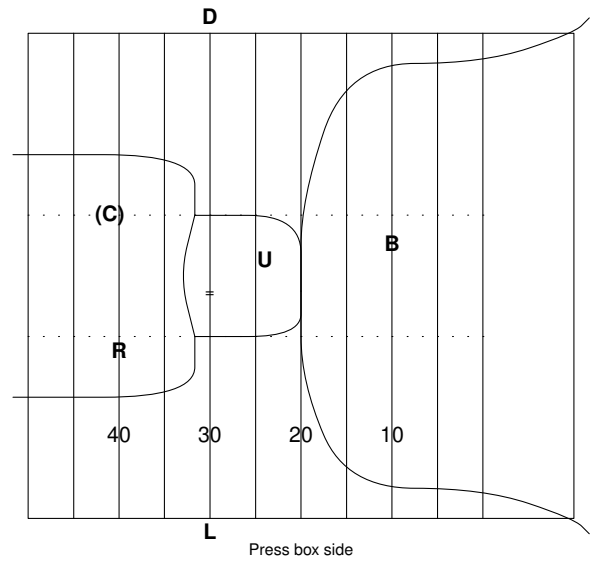
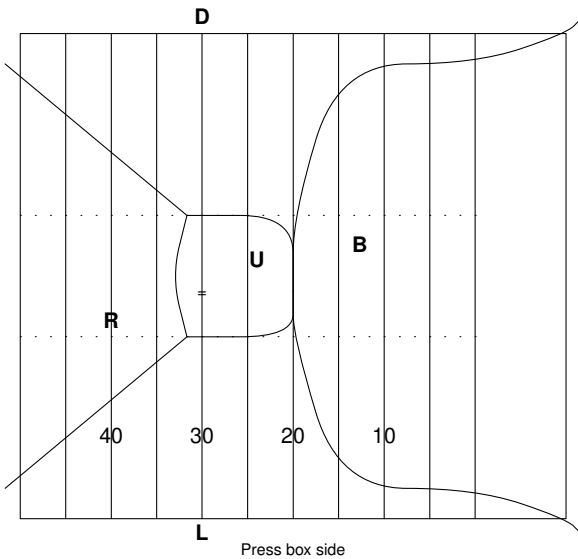

Figure C: Crew of 5 (pass play coverage zones)



Officials have **primary** coverage of any or all receivers in their area (as shown in the diagram left), but (with the exception of the Referee, and on long passes, the Umpire) are expected to provide secondary coverage of the area around the destination of any forward pass.

Figure D: Crew of 6D

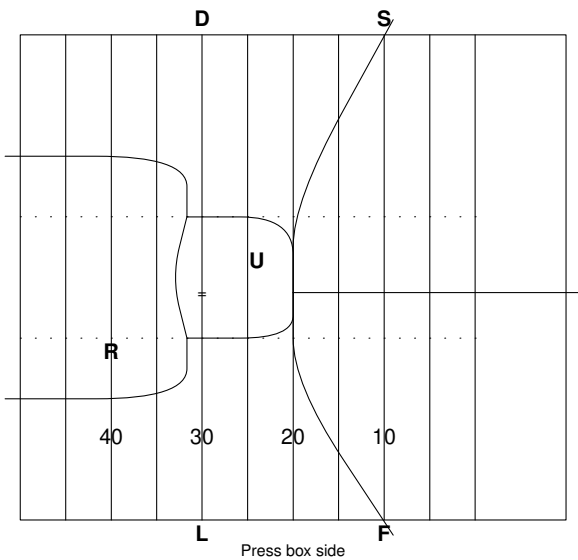

Figure E: Crew of 7

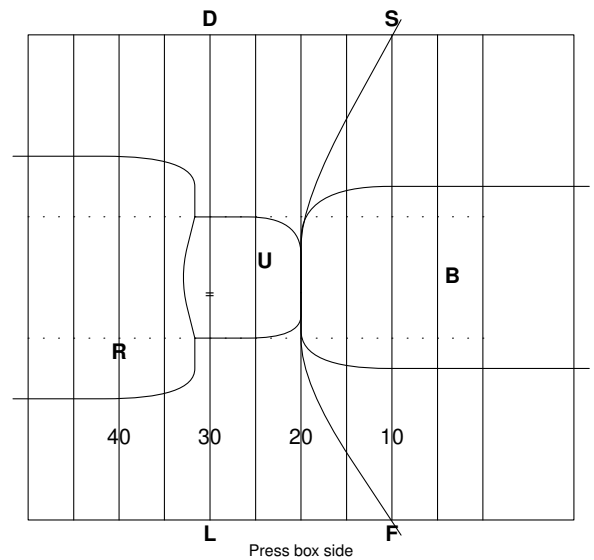

Figure F: Crew of 8

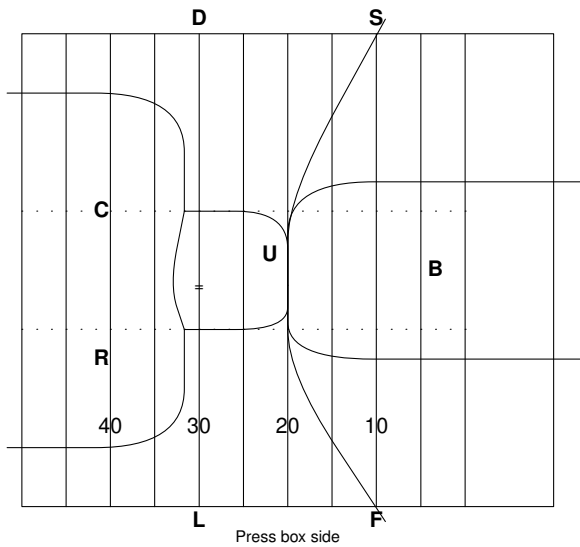
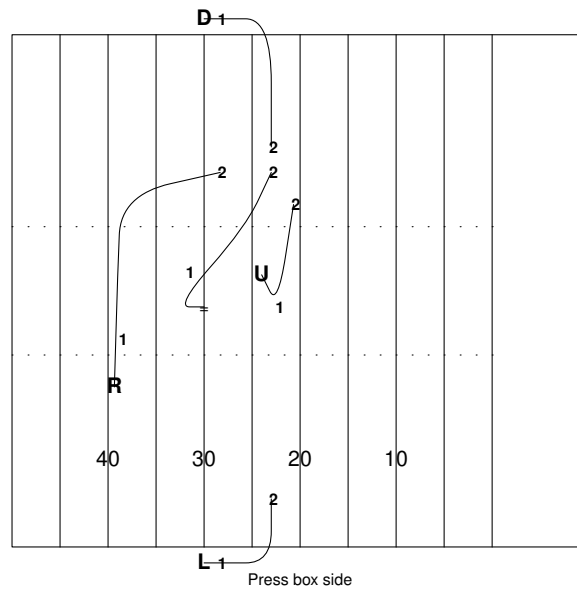
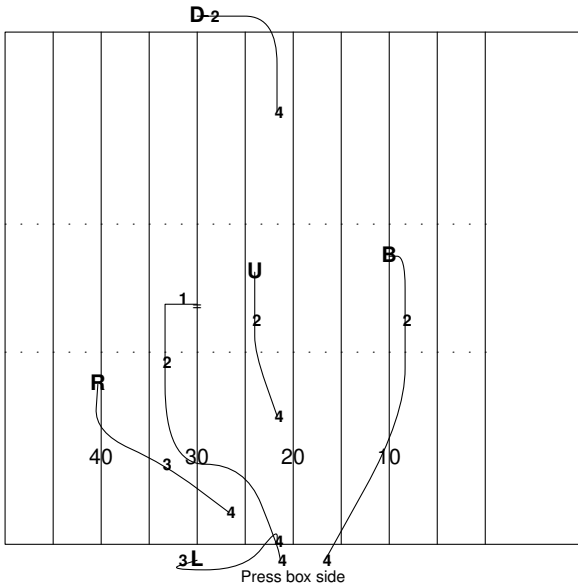

Figure G: Example play (Crew of 4) run up the middle of the field



As the play develops (1), the Umpire moves back and laterally to stay away from the hole at the point of attack. As the ball carrier approaches the neutral zone, the [Down Judge](#) takes over responsibility for them and moves to the dead-ball spot when they are tackled (2) to mark the forward progress. The Umpire and Referee observe action ahead of and around the ball carrier.

Figure H: Example play (Crew of 5) sweep to Line Judge's side of the field



At the snap (1) the officials read their keys to determine what the play is. Once it is determined to which side of the field the play is being run (2), the Line Judge makes sure they are well out of the way and the Back Judge moves across the field to observe lead blocks. The Umpire turns and watches the play from the inside. When the ball carrier turns up field (3), responsibility for them passes from the Referee to the Line Judge. The Referee switches to watching blocks around the ball carrier while the Line Judge follows the ball carrier up the sideline. When the ball carrier goes out of bounds (4), the Line Judge marks the dead-ball spot and observes continuing action against the ball carrier. The Referee and Back Judge move quickly into the vicinity to assist in coverage, with either going into the team area if necessary. The Umpire moves downfield to cover action around and ahead of the ball carrier. Throughout the play the Down Judge is responsible for action in the centre of the field behind the Referee and Umpire.

Figure I: Example play (Crew of 4) pitchout option play

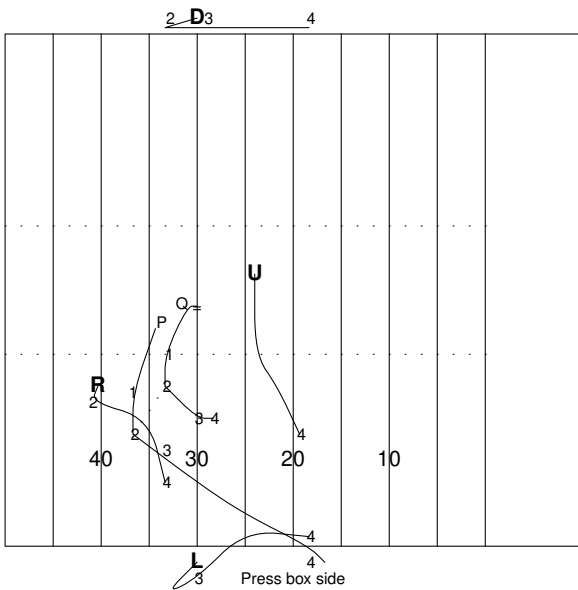

The Referee maintains coverage as the quarterback (Q) rolls out to the Line Judge's side of the field (1). The Line Judge steps into the backfield to observe the trailing back (P). If the ball is pitched to the outside back (2) the Referee watches for continuing action against the quarterback while the Line Judge takes the ball and the ball carrier. If the ball is not pitched then the Line Judge watches the trailing back until the quarterback crosses the neutral zone (3) and then takes responsibility for them. The Down Judge takes a position to assist on ruling whether the pitch goes backwards or forwards. The Umpire at all times watches the action at the point of attack and in front of the ball carrier.

Figure J: Example play (Crew of 5) pass downfield to Down Judge's side of field

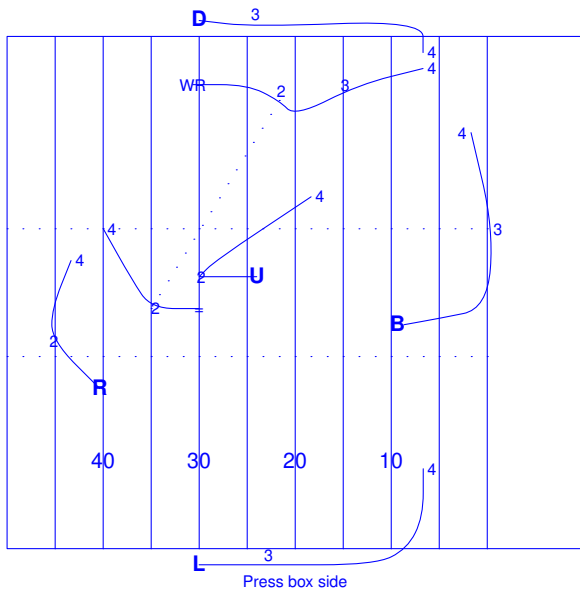

As the quarterback drops back into the pass pocket (1) the Referee drops back correspondingly to keep out of the way, maintaining coverage of players in the backfield. The Umpire steps up into the neutral zone in order to be able to rule on whether the pass crosses it. The wing officials stay on the line of scrimmage **until they are confident a pass is going to be thrown that will definitely cross the neutral zone.**^o The Back Judge moves back to keep the potential receivers between themselves and the wing officials. When the quarterback throws the ball (2) the Referee must continue to watch them in case of roughing the passer fouls. The Umpire turns and watches the pass in flight in order to be able to rule on whether it is caught or incomplete. The **Down Judge** and Back Judge also watch the receiver and those around them for illegal action. After the pass is complete and the ball carrier is progressing downfield they are the **Down Judge's** responsibility (3). Other officials watch the action around the ball and the Referee cleans up any action remaining around the line of scrimmage. When the ball carrier is tackled (4), the **Down Judge** moves to the dead-ball spot and the Back Judge assists with coverage and, after all action has ceased, with relaying a ball to the inbounds spot.

Figure K: Example play (Crew of 4) interception return

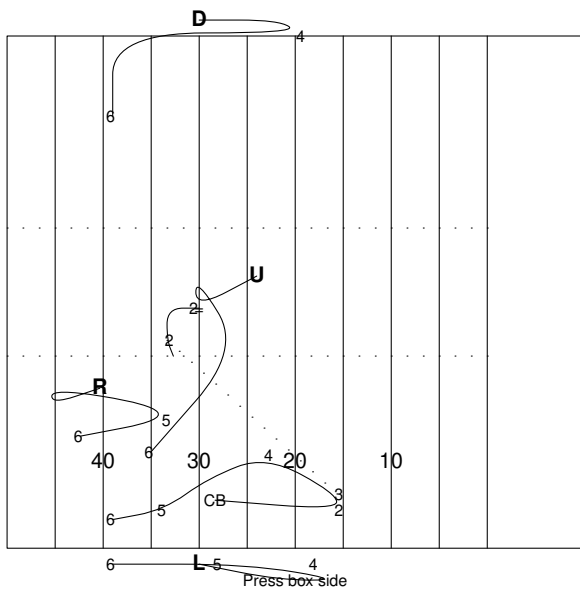

As the officials read pass (1), the Referee backs up to stay clear of the passer, the Umpire steps up towards the neutral zone and the wing officials stay on the line of scrimmage. At the time the pass is thrown (2) the Line Judge and **Down Judge** are watching for contact between all eligible receivers on their side of the field. With the pass in the air the Umpire pivots to watch the point where it comes down and the Line Judge, having determined the most likely receiver, watches for pass interference, etc. When the pass is intercepted by the cornerback (CB) (3), the Line Judge has responsibility for the ball carrier and the Umpire watches blocking on the return (4 and 5). When the ball carrier is tackled (6), the Line Judge has the dead-ball spot and, after ensuring that there are no continuing action fouls, the Referee assists in retrieving/relaying a ball to the inbounds spot. Throughout the return the **Down Judge** observes action away from the ball and helps with forward progress.

Figure L: Example play (Crew of 8) interception return

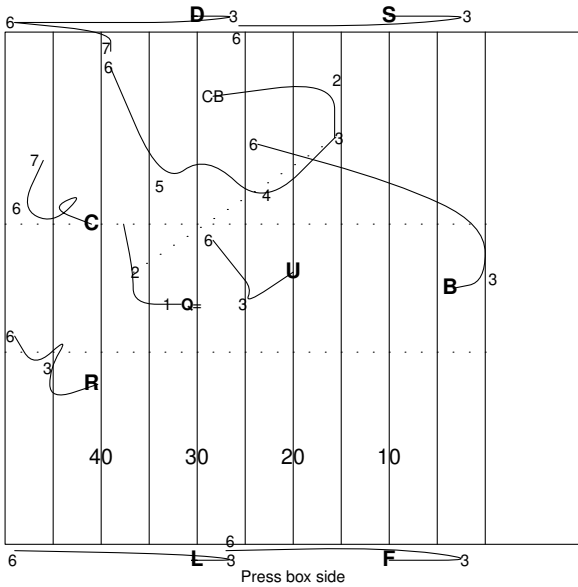

All the officials read pass (1), and the Referee and Centre Judge retreat to stay clear of the passer as they drop back, while the Umpire steps up a few yards. The Down Judge and Line Judge hold the line of scrimmage, while the deep officials drop back as receivers run downfield. When the pass is thrown (2), all wing and deep officials attempt to identify the destination of the pass. The pass is intercepted by the cornerback (CB) (3). At this point, all officials switch to reverse mechanics in order to cover the return. The Referee, Centre Judge, Down Judge and Line Judge all need to stay ahead of the ball carrier during the return (4). The three deep officials have a lot of ground to make up, especially the Side Judge who has primary responsibility for the ball carrier as they weave around the field (5). When the ball carrier is tackled (6), preferably the Side Judge will mark the forward progress spot, but since they are delayed in doing so, the Down Judge moves to mark it (7). The other officials keep the end of the play boxed in, and watch peripheral players for late contact.

26.3 - Basic goal line responsibilities

Figure A: Crew of 4

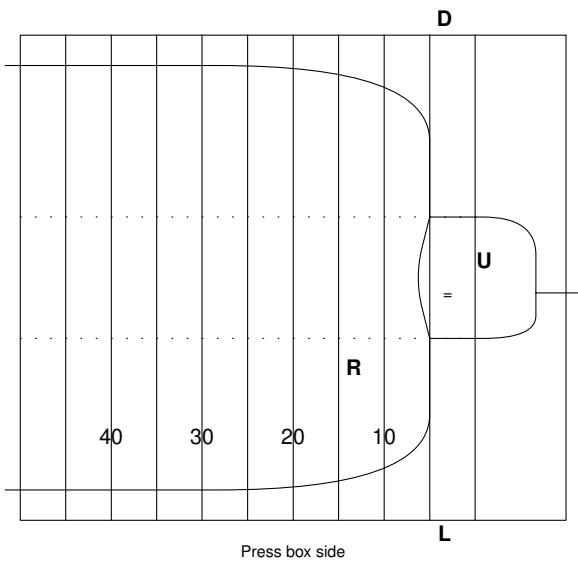

Figure B: Crew of 5/6C

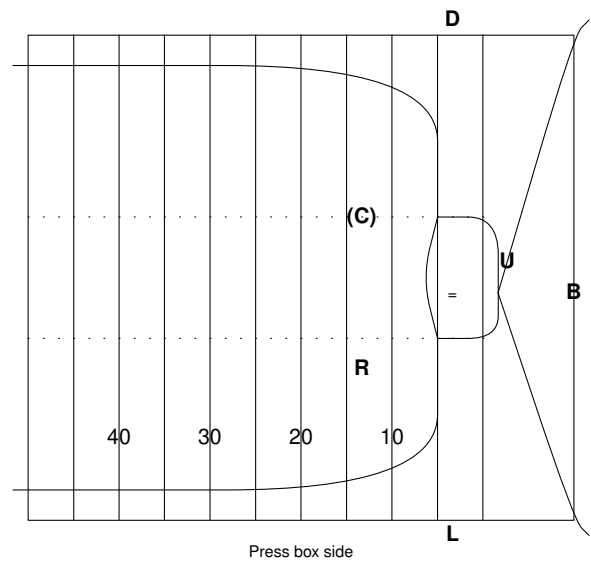

Figure C: Crew of 6D

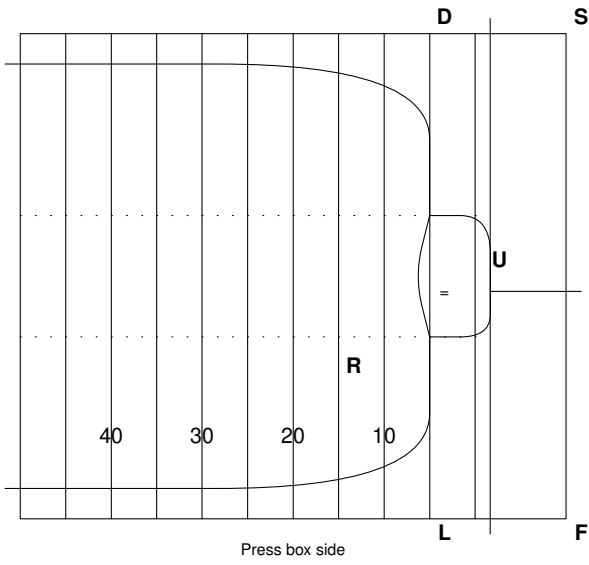

Figure D: Crew of 7/8 (ball outside 20-yard line)

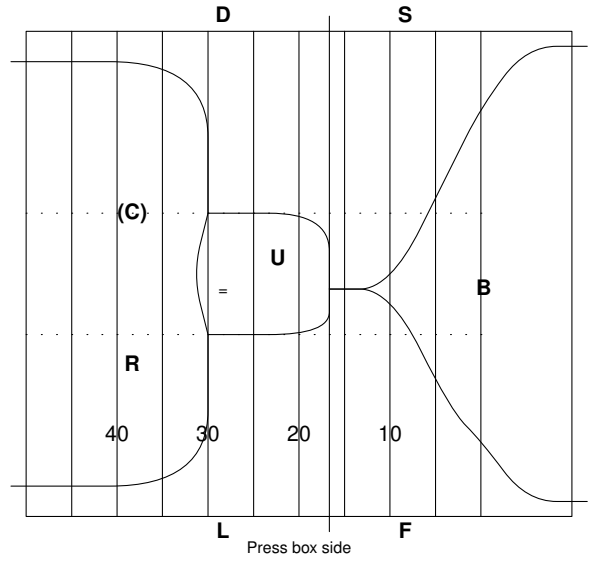

Figure E: Crew of 7/8 (ball between 7 & 20-yard lines)

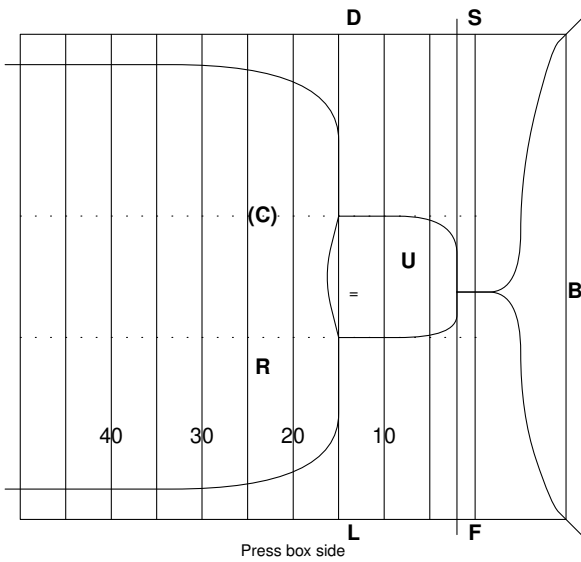
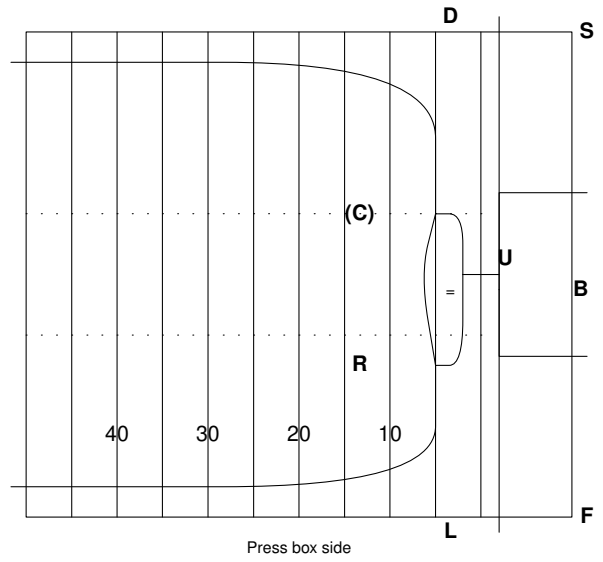

Figure F: Crew of 7/8 (ball inside 7-yard line)



26.4 - Basic punt responsibilities

Figure A: Crew of 4

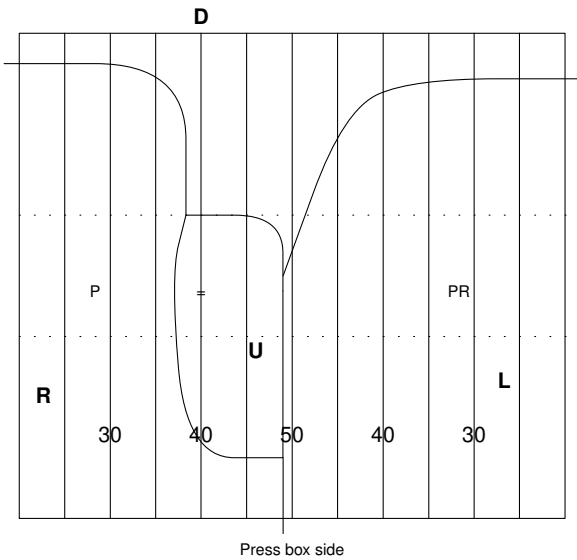

Figure B: Crew of 5/6C

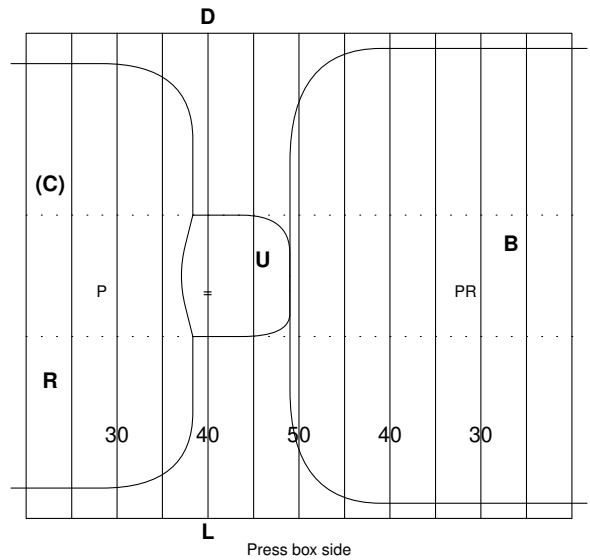

Figure C: Crew of 6D

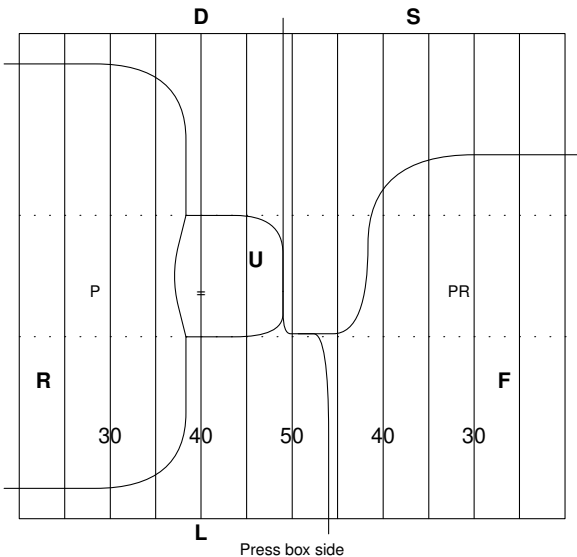

Figure D: Crew of 7/8

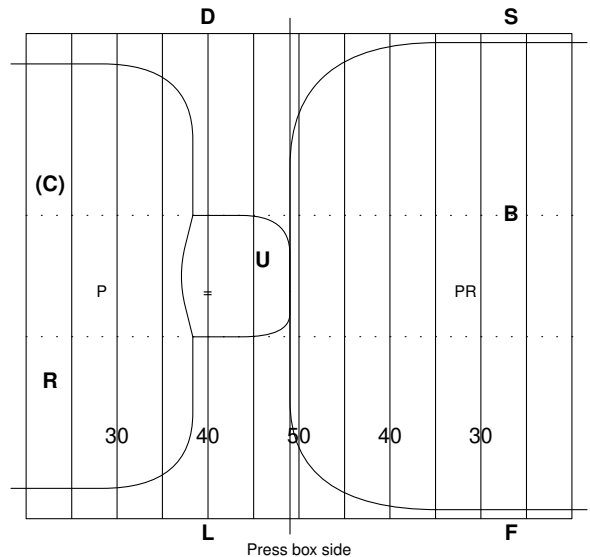
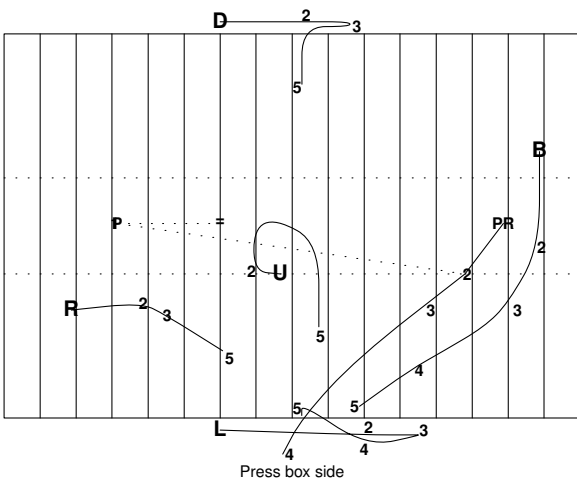

Figure E: Example play (Crew of 5) punt return



The Referee concentrates on action in the backfield especially against the kicker after the ball is kicked (1). When the ball is kicked the Line Judge moves downfield until they are approximately 15-20 yards ahead of the return. The Back Judge remains behind the deep receiver so that they can observe the catch (2), and then blocks in front of the returner (3). The Line Judge follows the ball carrier until they go out of bounds (4) with the Referee and Umpire observing action ahead of the ball carrier and the Back Judge watching for continuing action fouls behind and around the ball carrier. The Down Judge observes players away from the ball. The Line Judge is the Coverer and will mark the dead-ball spot while the Referee and Back Judge assist in returning the ball to the inbounds spot (5) once all action has ceased.

26.5 - Basic field goal or try attempt responsibilities

(Arrows show direction officials should move if Team A switch to a run/pass formation)

Figure A: Crew of 4

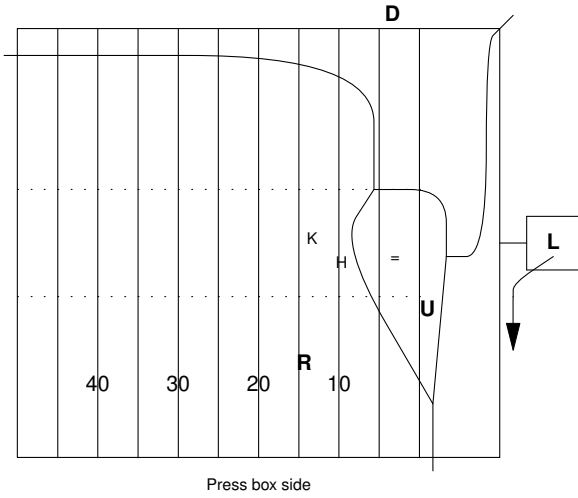

Figure B: Crew of 5

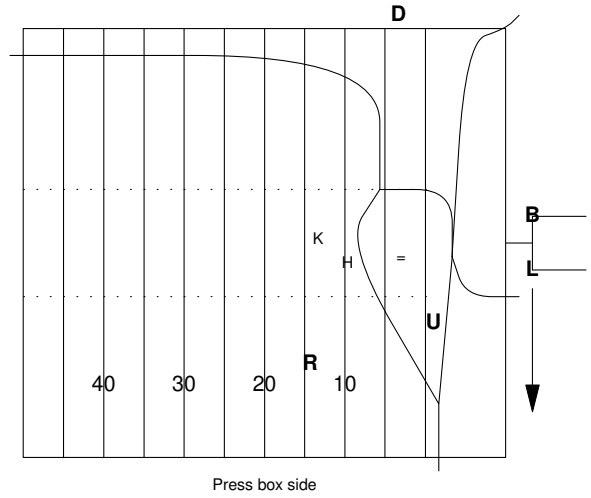

Figure C: Crew of 6D

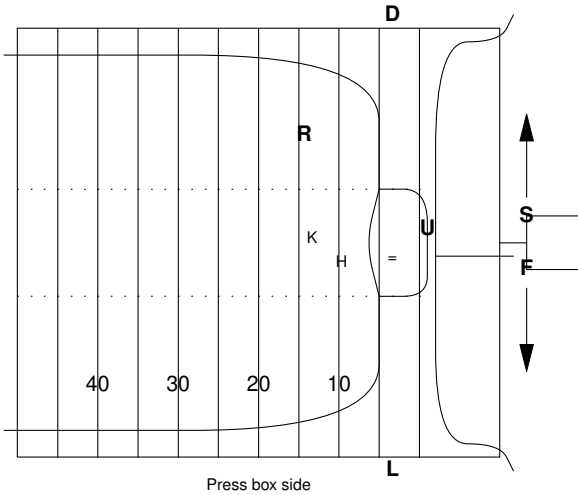

Figure D: Crew of 6C

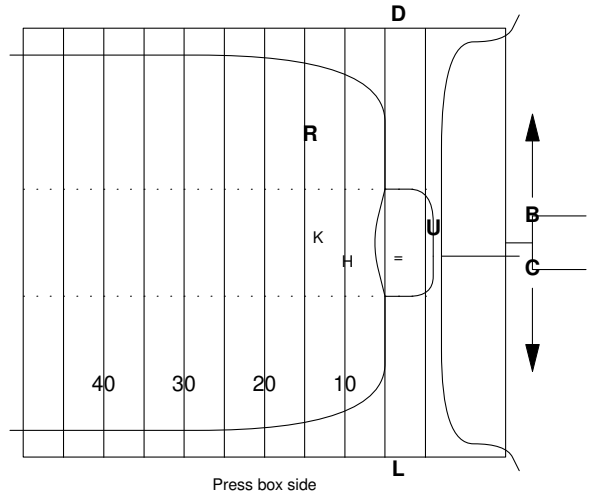

Figure E: Crew of 7

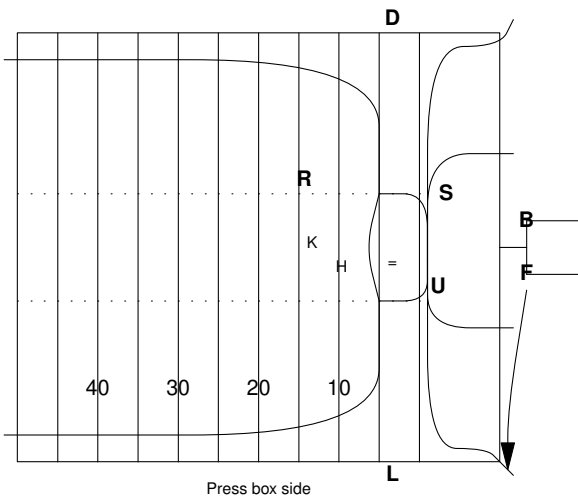

Figure F: Crew of 8

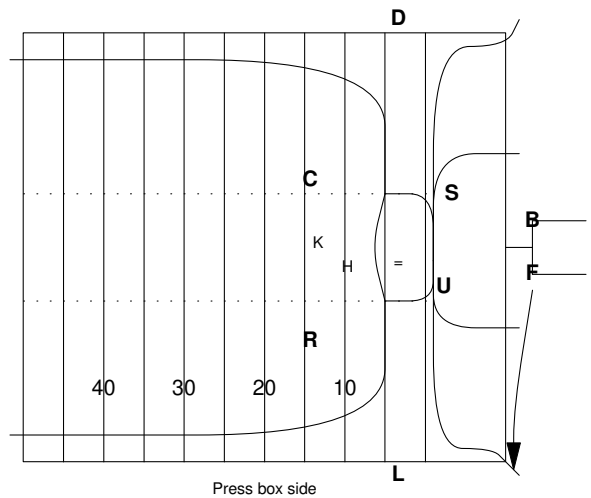
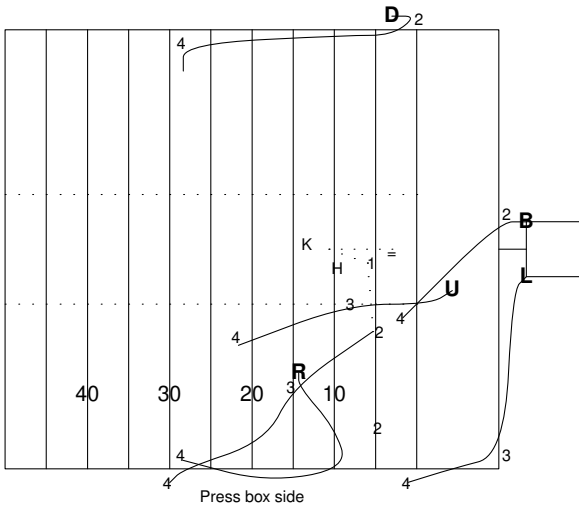

Figure G: Example play (Crew of 5) blocked field goal attempt



The field goal attempt is blocked behind the line of scrimmage (1). The Referee immediately responds by moving towards the press box sideline, maintaining a position clear of action around the ball. The Umpire stays on the goal line ready to rule if the ball is advanced, and the **Down Judge** also moves to the goal line for the same reason. The Line Judge moves towards the corner pylon while the Back Judge moves up to the end line. The ball is recovered by the defense (2) and advanced away from the end zone. The Referee has sideline responsibility and covers the ball carrier, while the Umpire moves to observe action around the ball carrier. As the other officials move to cover continuing action away from the ball (3) the Referee follows the ball carrier up the sideline until the ball carrier is forced out of bounds (4). The Umpire and Line Judge must get into position to observe action around the ball carrier, even if from a distance. The Back Judge observes the players still around the original line of scrimmage. The **Down Judge** keeps up with the ball carrier and helps by mirroring the forward progress spot.

27. SUPPLEMENTARY SIGNALS

The official football signals [S1 to S47] are described in the rulebook, but in practice officials supplement these with signals of their own or other people's invention in order to aid communication in situations where verbal communication is either impossible or undesirable.

All signals are means of visually communicating a message. The source of the message is the official who gives the signal. The destination of the message may be, in different cases, other officials, players, coaches or spectators. Visual signals may have to be used where either distance or noise prevent audible signals from being heard, or where an audible signal is inappropriate.

No.	Message	Signal
Sup1	the Team A player nearest me is off the line of scrimmage	arm outstretched (with hand open) approximately 90-degrees to the ground, pointing into Team A's backfield
Sup3	the team I am responsible for counting has the correct number of[†] players on the field	clenched fist between waist and shoulder height with upward pointing thumb; arm outstretched to side (see also Sup24)
Sup4	the team I am responsible for counting has too many[‡] players on the field	hand on top of head
Sup5	the last pass was a backward pass	punch arm into offensive backfield
Sup6	Team A has more than 10 yards to go to the line to gain (2-stakes)	wagging index fingers discretely at chest height
Sup8	the game clock stops after the next play	crossed wrists in front of chest
Sup9	Team A is attempting a kick at goal	form hands into Δ shape with fingertips touching
Sup10	Team A is "going for it" – they are not attempting a kick in a 4th down or PAT situation	roll hands (like S19) above head
Sup11	the game clock starts on the snap	click fingers
Sup12	the game clock starts on the ready or is running	circular motion of the index finger from wrist
Sup13	(i) team has chosen to receive (ii) I am selling the fact that the catch was complete (use rarely)	clutch hands to chest in catching motion
Sup14	the pass was caught out of bounds (incomplete)	throw arms to out of bounds side
Sup15	the field goal attempt was no good (wide)	as Sup14
Sup16	please guide me to the out of bounds spot	one hand in air
Sup17	come up the sideline towards me	beckon with palm of hand towards self
Sup18	move down the sideline away from me	gesture with palm of hand away from self
Sup19	stop, you are at the out of bounds spot	hack down
Sup20	advance the stadium clock (i.e. it is slow with respect to the on-field clock)	signal S2 until the clock shows the correct time, then give signal S3
Sup21	delay the stadium clock (i.e. it is fast with respect to the on-field clock)	signal S21 to hold (delay) the stadium clock, then give signal S2 to restart it when the on-field clock catches up
Sup22	turn the stadium clock off	tap watch then give uncatchable pass signal [S17]
Sup23	take a knee play notification	tap raised knee
Sup24	the team I am responsible for counting has fewer than the required number of[‡] players on the field	clenched fist with downward pointing thumb; arm outstretched to side (see also Sup3)
Sup25	I believe all the conditions for a touchdown are met	fists together (in front of chest) with thumbs up
Sup26	the receiver touched the ball inbounds but did not have control of it until they were out of bounds	move hands (palms up) alternately up and down in front of chest
Sup27	the down box is displaying the wrong number	give signal S17 (uncatchable forward pass) before the snap
Sup28	I have responsibility for the kick returner/ball	punch in the direction of the receiving team's end line

No.	Message	Signal
Sup29	reset play clock to 25 seconds	pump one arm vertically with palm of hand facing upwards
Sup30	reset play clock to 40 seconds	pump two arms vertically with palms of hands facing upwards
Sup31	fourth down fumble rule is in effect	roll hands (like S19) in front of chest
Sup32	nose of ball is on yard line	tap nose with fingers
Sup33	middle of ball is midway between two yard lines	tap belt buckle with fingers
Sup34	tail of ball is on yard line	tap hip with fingers
Sup35	Team A has made the line to gain (first down)	point with index finger in front of chest in direction of Team B's end line
Sup36	Team B is matching substitutes	hold arms out wide horizontally with hands closed (like signal S4)
Sup37	team wishes 10-second runoff	tap watch then point down
Sup38	team wishes NO 10-second runoff	tap watch then signal incomplete [S10]
Sup39	reminder that the umpire has primary responsibility for retrieving and spotting the ball (e.g. in the last 2 minutes of a half)	make a U shape with the thumbs and index fingers of both hands
Sup40	please tell me how much time is remaining in the period	tap watch or wrist
Sup41	there is less than two minutes[®] remaining in the period (if given by timekeeper) is there less than two minutes remaining in the period? (if given by anyone else) [@]	point down with both index fingers
Sup42	the ball/ball carrier did/did not cross the neutral zone	point at the ground on the appropriate side of the neutral zone (behind if it did not cross; beyond if it did)
Sup43	penalty yards will give a first down (if given by Down Judge) will penalty yards give a first down? (if given by anyone else) [@]	open hand with fingers spread held up against chest
Sup44	the previous play is under review	draw a rectangle (TV screen) using two index fingers at face height
Sup45	two-minute warning	make a T-shape by raising the fingertips of one hand to touch the palm of the other at chest height

Signals Sup11 and Sup12 are intended primarily for communication between the Referee and the on-field timekeeper.

Signals Sup16 to Sup19 are intended for kick out of bounds situations.

Signals Sup20 to Sup22 are intended for communication with the stadium clock operator.

Signals Sup2 and Sup7 are no longer used.

28. PENALTY CODES

Alphabetically by code:

Code	Foul
APS	Altering playing surface
ATR	Assisting the runner
BAT	Illegal batting
DEH	Holding, defense
DOD	Delay of game, defense
DOF	Offside, defense
DOG	Delay of game, offense
DPI-AB	Pass interference, defense, arm bar
DPI-CO	Pass interference, defense, cut off
DPI-GR	Pass interference, defense, grab and restrict
DPI-HT	Pass interference, defense, hook and turn
DPI-NPB	Pass interference, defense, not playing the ball
DPI-PTO	Pass interference, defense, playing through opponent
DSH	Delay of game, start of half
DSQ	Disqualification
ENC	Encroachment (offense)
FGT	Fighting
FST	False start
IBB	Illegal block in the back
IBK	Illegal block during kick
IBP	Illegal backward pass
IDP	Ineligible downfield on pass
IFD	Illegal formation, defense (3-on-1)
IFH	Illegal forward handing
IFK	Illegal free kick formation
IFP	Illegal forward pass
IKB	Illegally kicking ball
ILF	Illegal formation
ILM	Illegal motion
ING	Intentional grounding
IPN	Improper numbering
IPR	Illegal procedure
ISH	Illegal shift
ISP	Illegal snap
ITP	Illegal touching of a forward pass
IUH	Illegal use of hands
IWK	Illegal wedge on kickoff
KCI	Kick-catch interference
KIK	Illegal kick
KOB	Free kick out of bounds
OBK	Out of bounds during kick
OFH-GR	Holding, offense, grab and restrict
OFH-HR	Holding, offense, hook and restrict
OFH-TD	Holding, offense, takedown
OFK	Offside, free kick
OPI-BK	Pass interference, offense, blocking
OPI-DT	Pass interference, offense, driving through
OPI-PK	Pass interference, offense, pick
OPI-PO	Pass interference, offense, pushing off
PF-BBW	Personal foul, blocking below the waist
PF-BOB	Personal foul, blocking out of bounds
PF-BSB	Personal foul, blind-side block
PF-CHB	Personal foul, chop block
PF-CLP	Personal foul, clipping
PF-FMM	Personal foul, face mask
PF-HCT	Personal foul, horse collar tackle
PF-HDR	Personal foul, hit on defenseless receiver
PF-HTF	Personal foul, hands to the face
PF-HUR	Personal foul, hurdling
PF-ICS	Personal foul, illegal contact with snapper
PF-LEA	Personal foul, leaping
PF-LHP	Personal foul, late hit/piling on

Code	Foul
PF-LTO	Personal foul, late hit out of bounds
PF-OTH	Personal foul, other
PF-RFK	Personal foul, roughing free kicker
PF-RTH	Personal foul, roughing the holder
PF-RTK	Personal foul, roughing the kicker
PF-RTP	Personal foul, roughing the passer
PF-SKE	Personal foul, striking/kneeing/elbowing
PF-TGB	Personal foul, targeting (both Rules 9-1-3 and 4)
PF-TGC	Personal foul, targeting (crown of helmet)
PF-TGD	Personal foul, targeting (defenseless player)
PF-TRP	Personal foul, tripping
PF-UNR	Personal foul, unnecessary roughness
RNH	Running into the holder
RNK	Running into the kicker
SLI	Sideline interference, 5 yards
SLM	Sideline interference, 15 yards
SLW	Sideline interference, warning
SUB	Illegal substitution
UC-2PN	Unsportsmanlike conduct, two players with same number
UC-ABL	Unsportsmanlike conduct, abusive language
UC-BCH	Unsportsmanlike conduct, bench
UC-DBS	Unsportsmanlike conduct, dead ball shoving
UC-DEA	Unsportsmanlike conduct, delayed/excessive act
UC-FCO	Unsportsmanlike conduct, forcibly contacting an official
UC-RHT	Unsportsmanlike conduct, removal of helmet
UC-SBR	Unsportsmanlike conduct, simulating being roughed
UC-STB	Unsportsmanlike conduct, spiking/throwing ball
UC-TAU	Unsportsmanlike conduct, taunting/baiting
UC-UNS	Unsportsmanlike conduct, other
UFA	Unfair acts
UFT	Unfair tactics

Alphabetically by foul:

Code	Foul
APS	Altering playing surface
ATR	Assisting the runner
DOD	Delay of game, defense
DOG	Delay of game, offense
DSH	Delay of game, start of half
DSQ	Disqualification
ENC	Encroachment (offense)
FST	False start
FGT	Fighting
KOB	Free kick out of bounds
DEH	Holding, defense
OFH-GR	Holding, offense, grab and restrict
OFH-HR	Holding, offense, hook and restrict
OFH-TD	Holding, offense, takedown
IBP	Illegal backward pass
BAT	Illegal batting
IBK	Illegal block during kick
IBB	Illegal block in the back
ILF	Illegal formation
IFD	Illegal formation, defense (3-on-1)
IFH	Illegal forward handing
IFP	Illegal forward pass
IFK	Illegal free kick formation
KIK	Illegal kick
IKB	Illegally kicking ball
ILM	Illegal motion
IPR	Illegal procedure
ISH	Illegal shift
ISP	Illegal snap
SUB	Illegal substitution
ITP	Illegal touching of a forward pass
IUH	Illegal use of hands

Code	Foul
IWK	Illegal wedge on kickoff
IPN	Improper numbering
IDP	Ineligible downfield on pass
ING	Intentional grounding
KCI	Kick-catch interference
DOF	Offside, defense
OFK	Offside, free kick
OBK	Out of bounds during kick
DPI-AB	Pass interference, defense, arm bar
DPI-CO	Pass interference, defense, cut off
DPI-GR	Pass interference, defense, grab and restrict
DPI-HT	Pass interference, defense, hook and turn
DPI-NPB	Pass interference, defense, not playing the ball
DPI-PTO	Pass interference, defense, playing through opponent
OPI-BK	Pass interference, offense, blocking
OPI-DT	Pass interference, offense, driving through
OPI-PK	Pass interference, offense, pick
OPI-PO	Pass interference, offense, pushing off
PF-BSB	Personal foul, blind-side block
PF-BBW	Personal foul, blocking below the waist
PF-BOB	Personal foul, blocking out of bounds
PF-CHB	Personal foul, chop block
PF-CLP	Personal foul, clipping
PF-FMM	Personal foul, face mask
PF-HTF	Personal foul, hands to the face
PF-HDR	Personal foul, hit on defenseless receiver
PF-HCT	Personal foul, horse collar tackle
PF-HUR	Personal foul, hurdling
PF-ICS	Personal foul, illegal contact with snapper
PF-LTO	Personal foul, late hit out of bounds
PF-LHP	Personal foul, late hit/piling on
PF-LEA	Personal foul, leaping
PF-OTH	Personal foul, other
PF-RFK	Personal foul, roughing free kicker
PF-RTH	Personal foul, roughing the holder
PF-RTK	Personal foul, roughing the kicker
PF-RTP	Personal foul, roughing the passer
PF-SKE	Personal foul, striking/kneeing/elbowing
PF-TGB	Personal foul, targeting (both Rules 9-1-3 and 4)
PF-TGC	Personal foul, targeting (crown of helmet)
PF-TGD	Personal foul, targeting (defenseless player)
PF-TRP	Personal foul, tripping
PF-UNR	Personal foul, unnecessary roughness
RNH	Running into the holder
RNK	Running into the kicker
SLI	Sideline interference, 5 yards
SLM	Sideline interference, 15 yards
SLW	Sideline interference, warning
UFA	Unfair acts
UFT	Unfair tactics
UC-ABL	Unsportsmanlike conduct, abusive language
UC-BCH	Unsportsmanlike conduct, bench
UC-DBS	Unsportsmanlike conduct, dead ball shoving
UC-DEA	Unsportsmanlike conduct, delayed/excessive act
UC-FCO	Unsportsmanlike conduct, forcibly contacting an official
UC-UNS	Unsportsmanlike conduct, other
UC-RHT	Unsportsmanlike conduct, removal of helmet
UC-SBR	Unsportsmanlike conduct, simulating being roughed
UC-STB	Unsportsmanlike conduct, spiking/throwing ball
UC-TAU	Unsportsmanlike conduct, taunting/baiting
UC-2PN	Unsportsmanlike conduct, two players with same number

Code PF-BTH has been deprecated (as of 2026) in favour of the three PF-TG* codes.

29. INDEX

- Action away from the ball 40
 Alternate crew 55, 56, 60, 73, 83, 94, 96, 97, 106, 116, 118, 119, 131, 157, 158, 162, 164
 Alternate officials 49
 Announcer 32, 55, 56
 Assisting the runner 65, 78, 91, 102, 113, 124, 136
- Backward pass signal 187
 Ball coming out of end zone 28
 Ball dead close to sideline 44
 Ball person 32, 46, 55, 56, 163
 Ball persons 158
 Ball relay 40, 46, 157
 Balls, carrying to field 55
 Balls, examination of 54
 Ball touched signal 64, 77, 78, 89, 92, 103, 112, 115, 126, 137, 160
 Blind-side block fouls 19, 60, 63, 64, 65, 66, 67, 74, 76, 77, 78, 79, 80, 84, 86, 88, 90, 91, 93, 97, 99, 100, 102, 106, 109, 110, 113, 114, 116, 119, 121, 122, 124, 125, 127, 131, 133, 134, 136, 154
 Blocking below the waist fouls *see* Illegal block below the waist fouls
 Boxing in 42
- Calling fouls 40
 Captain's toss options 59
 Celebrations 23, 25, 89, 101, 104, 112, 123, 127, 135, 138
 Chain 28, 32, 48, 55, 82, 85, 95, 108, 117, 148, 149, 154, 157
 Chain crew 32, 49, 54, 55, 60, 70, 73, 83, 93, 97, 106, 116, 119, 131, 158, 161, 164
 Chop block fouls 19, 60, 63, 64, 65, 66, 67, 74, 76, 77, 78, 79, 80, 84, 86, 88, 90, 91, 93, 97, 99, 100, 102, 106, 109, 110, 113, 114, 116, 119, 121, 122, 124, 125, 127, 131, 133, 134, 136, 154
 Clearer (ball relay) 46
 Clipping fouls 16, 30
 Clock operator, stadium 55, 56
 Clotheslining 16
 Coach 32
 Coach, relay penalties to 154
 Coach's certification 54
 Coach's conference 148
 Communication 43
 Complaints 34, 35
 Conspicuous actions 14
 Co-operation with other officials 43
 Counting players 49
 Coverer (ball relay) 46, 47
 Crew radio 4, 10, 43, 49, 50, 56, 59, 60, 71, 77, 86, 87, 88, 89, 101, 105, 108, 109, 111, 112, 121, 123, 125, 129, 135, 139, 150, 152, 153, 156, 157, 158, 165, 166, 167
- Dead-ball signal 152
 Deep wing official, definition of 4
 Defenseless player 19
 Defensive pass interference fouls *see also* Pass interference fouls, 17, 141
 Deferred toss options 59
 Delay of game fouls 20, 71, 105, 130, 139
 Disconcerting signals fouls 21
- Discretion 34
 Disqualifying foul 19, 20, 48, 151
 Dissent 24
 Double umpire 99, 128, 133
 Down box 161
 Duration of game 48, 49
 Duration of timeouts 49
- Eligible receiver 20
 Encroachment foul 22
 End of period 161
 Equipment, players' 32, 54, 55, 82
 Erroneous rulings 40
- Face mask fouls 18, 60, 63, 64, 65, 66, 67, 74, 76, 77, 78, 79, 80, 84, 86, 88, 90, 91, 93, 97, 99, 100, 102, 106, 109, 110, 113, 114, 116, 119, 121, 122, 124, 125, 127, 131, 133, 134, 136, 154
 Failure to wear mandatory equipment 23
 Fair catch signal 20, 28, 60, 62, 73, 79, 83, 91, 97, 102, 106, 114, 119, 125, 131, 136
 False start fouls 15, 21, 62, 67, 75, 76, 85, 86, 93, 107, 108
 Field clock *see* Stadium clock
 Field markings 28
 Fighting fouls 26, 48
 Flagrant unsportsmanlike conduct 25
 Flanker back 140
 Free kick out of bounds fouls 15, 60, 73, 83, 97, 106, 119, 131
 Fumble 48, 160
- Game clock 49
 Game management 32
 General duties 40
 Get-back coach 43
- Half-time activities 32
 Head coach *see* Coach
 Holding fouls 15, 30, 60, 63, 64, 65, 66, 67, 74, 76, 77, 78, 79, 80, 83, 86, 88, 90, 91, 93, 97, 99, 100, 102, 106, 109, 110, 113, 114, 116, 119, 121, 122, 124, 125, 127, 131, 133, 134, 136, 140
 Horse collar tackle fouls 19, 154
- Illegal batting fouls 104, 127, 138
 Illegal block below the waist fouls 16, 60, 65, 66, 74, 78, 79, 80, 83, 86, 88, 90, 91, 93, 97, 99, 100, 102, 106, 109, 110, 113, 114, 116, 119, 121, 122, 124, 125, 127, 131, 133, 134, 136
 Illegal block in the back fouls 16, 30, 60, 63, 64, 65, 66, 67, 74, 76, 77, 78, 79, 80, 83, 86, 90, 91, 93, 97, 99, 102, 106, 109, 113, 114, 116, 119, 121, 124, 125, 127, 131, 133, 136
 Illegal equipment violations 23, 54
 Illegal formation 20
 Illegal formation fouls 20, 66, 67, 79, 80, 93, 96, 116, 118, 127, 129
 Illegal forward handing foul 60, 74, 84, 97, 106, 119, 131
 Illegal forward handing fouls 23
 Illegal forward pass foul 60, 74, 84, 97, 106, 119, 131
 Illegal forward pass fouls 64, 65, 88, 110

- Illegal motion fouls 22, 30, 85, 107
 Illegal substitution fouls 15, 22, 62, 75, 85, 96, 98, 108, 118, 121, 129, 132
 Illegal touching fouls 15, 22, 88, 100, 104, 110, 122, 127, 134, 138
 Illegal touching violations 62, 73, 74, 75, 83, 85, 91, 92, 97, 98, 102, 103, 106, 107, 114, 115, 119, 120, 125, 126, 131, 136, 137, 160
 Illegal use of hands fouls 16, 30, 88, 100, 110, 122, 134, 140
 Illegal wedge fouls 23, 60, 74, 84, 97, 106, 119, 131
 Ineligible receiver 20
 Ineligible receiver downfield fouls 22, 77, 88, 110
 Injury 40, 148
 Intentional grounding fouls 22, 64, 77, 89, 101, 112, 123, 135
 Interval after score 49
 Interval between periods 49
 Introducing captains 58

 Junior players 14

 Kick-catch interference fouls 20, 60, 62, 73, 79, 83, 91, 97, 102, 106, 114, 119, 125, 131, 136
 Kickoff time 32, 54
 Kick out of bounds signals 187
 Kick wide signal 187

 Late hit fouls 18, 60, 62, 63, 64, 65, 66, 67, 74, 76, 77, 78, 79, 80, 84, 86, 87, 88, 90, 91, 93, 97, 99, 100, 101, 102, 106, 109, 110, 113, 114, 116, 119, 121, 122, 124, 125, 127, 131, 133, 134, 136
 Lateral placement 70, 81
 Leaping fouls 80, 127
 Leverage fouls 80, 127

 Marking spots 45
 Measurement 69, 70, 82, 95, 117, 149, 162, 164
 Media 35
 Medical facilities 32
 Medical personnel 33

 National anthem 32, 56, 57, 59
 New series awarded 161
 Nose of ball 46, 187
 Note, mental 4
 Numbering exceptions 79

 O2O 4, 10, 43, 49, 50, 56, 59, 60, 71, 77, 86, 87, 88, 89, 101, 105, 108, 109, 111, 112, 121, 123, 125, 129, 135, 139, 150, 152, 153, 156, 157, 158, 165, 166, 167
 Offensive pass interference fouls see also Pass interference fouls, 18, 140, 141
 Officials' Conduct 34
 Offsetting fouls 154
 Offside fouls 15, 21, 23, 85, 93, 107
 Off-the-line signal 85, 108, 187
 One Judge mechanic 68, 94, 104
 Out of position 40

 Pass interference fouls 17, 18, 77, 88, 100, 110, 122, 134, 151
 Penalty declined signal 154
 Personal foul signal 154
 Pivotal plays 37
 Play clock 49, 55, 56, 71

 Player out of bounds fouls 23, 60, 74, 84, 97, 106, 119, 131
 Point of attack 14
 Postscrimmage kick enforcement spot 152, 160
 Pre-game ceremonies 55, 56
 Pre-game conference 51, 54
 Press 35
 Preventive officiating 34
 Public radio 4, 32, 58, 71, 147, 152, 154, 156, 157, 166, 168, 169

 Ready for play 28
 Ready for play signal 61, 147
 Rearrangement of assignments 40
 Record, written 4, 48
 Relayer (ball relay) 46, 47
 Retriever (ball relay) 46, 47
 Reverse 87, 109
 Roster 32, 54
 Roughing/running into the kicker fouls 17, 31, 66, 67, 74, 154
 Roughing the passer fouls 17, 64, 154
 Roughing the snapper fouls 19, 79, 80, 127, 154
 Runoff, 10-second 71, 95, 117, 129, 152, 153, 187

 Safety of players 34
 Sideline interference 26
 Sideline official, definition of 4
 Sideline warning 48
 Simulating being roughed fouls 25
 Simulating other fouls 25
 Slot back 140
 Spectators 34
 Split end 140
 Spot of foul 150, 152
 Spotter (ball relay) 46, 47
 Stadium clock 55, 56, 156
 Start the clock signal 71
 Start time see Kickoff time
 Steam whistle 147
 Subtraction, 10-second see Runoff, 10-second

 Tail of ball 46, 187
 Take a knee play 26, 99, 121, 133
 Taping 54
 Targeting fouls 19, 65, 78, 91, 102, 113, 124, 136, 154
 Team B movement and signals fouls 21
 Tempo 40
 Tight end 85, 98, 108, 121, 132, 140
 Timeout, charged 48, 49, 147
 Timeout, officials' 148
 Toss ceremony 32, 58
 Toss, result of 48
 Touchback 28
 Towels 32, 163
 Tripping fouls 60, 63, 64, 65, 66, 67, 74, 76, 77, 78, 79, 80, 84, 86, 88, 90, 91, 93, 97, 99, 100, 102, 106, 109, 110, 113, 114, 116, 119, 121, 122, 124, 125, 127, 131, 133, 134, 136
 Two-minute warning 156
 Two-minute warning signal 156

 Uncatchable pass signal 89, 100, 111, 123, 135
 Unfair clock tactics 71, 95, 117, 129
 Unnecessary roughness fouls 16, 19, 26, 62, 63, 86, 109
 Unsportsmanlike conduct fouls 23, 31, 48, 90, 101, 113, 124

Unusual play situations 54

Warm-up exercises 35

Wing official, definition of 4

Youth players 14

